

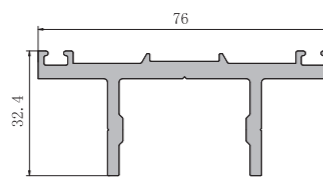

型号 Dwg NO.	PSMQ8012	名称 Profile	玻璃夹	壁厚(mm) Thickness	重量(kg/m) Weight	1.369	
型号 Dwg NO.	PSMQ800AG	名称 Profile	盖板	壁厚(mm) Thickness	重量(kg/m) Weight	0.133	
型号 Dwg NO.	PSMQ800A	名称 Profile	压座	壁厚(mm) Thickness	重量(kg/m) Weight	0.287	
型号 Dwg NO.	PSMQ8001GX	名称 Profile	横梁组件	壁厚(mm) Thickness	重量(kg/m) Weight	0.148	
型号 Dwg NO.		名称 Profile		壁厚(mm) Thickness	重量(kg/m) Weight		
型号 Dwg NO.		名称 Profile		壁厚(mm) Thickness	重量(kg/m) Weight		
型号 Dwg NO.		名称 Profile		壁厚(mm) Thickness	重量(kg/m) Weight		
型号 Dwg NO.		名称 Profile		壁厚(mm) Thickness	重量(kg/m) Weight		

型号 Dwg NO.	GR63CS-A	名称 Profile	竖纱	壁厚(mm) Thickness	重量(kg/m) Weight	0.215	
型号 Dwg NO.	GR63CS-F	名称 Profile	下横纱	壁厚(mm) Thickness	重量(kg/m) Weight	0.199	
型号 Dwg NO.	GR63CS-B	名称 Profile	上横纱	壁厚(mm) Thickness	重量(kg/m) Weight	0.207	
型号 Dwg NO.	GR63CS-C	名称 Profile	纱窗角码	壁厚(mm) Thickness	重量(kg/m) Weight	0.967	
型号 Dwg NO.	GR63CS-D	名称 Profile	竖纱	壁厚(mm) Thickness	重量(kg/m) Weight	0.219	
型号 Dwg NO.	GR63CS-G	名称 Profile	竖纱	壁厚(mm) Thickness	重量(kg/m) Weight	0.23	
型号 Dwg NO.	GR63CS-E	名称 Profile	下横纱	壁厚(mm) Thickness	重量(kg/m) Weight	0.184	
型号 Dwg NO.	GR838SC	名称 Profile	纱窗	壁厚(mm) Thickness	重量(kg/m) Weight	0.265	
型号 Dwg NO.	GR7006A	名称 Profile	纱窗	壁厚(mm) Thickness	重量(kg/m) Weight	0.493	
型号 Dwg NO.	XT-SC	名称 Profile	纱窗	壁厚(mm) Thickness	重量(kg/m) Weight	0.316	

型号 Dwg NO.	GR8312	型号 Dwg NO.	GR8007
名称 Profile	纱窗料	名称 Profile	纱扇
壁厚(mm) Thickness	重量(kg/m) Weight	壁厚(mm) Thickness	重量(kg/m) Weight
1.0	0.32	1.4	0.439
			
型号 Dwg NO.	GRSC01	型号 Dwg NO.	GRSC02
名称 Profile	纱窗	名称 Profile	纱扇
壁厚(mm) Thickness	重量(kg/m) Weight	壁厚(mm) Thickness	重量(kg/m) Weight
1.2	0.316	1.2	0.316
			
型号 Dwg NO.	GR8312A		
名称 Profile	纱窗料		
壁厚(mm) Thickness	重量(kg/m) Weight		
1.0	0.41		
			

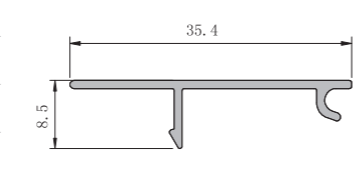
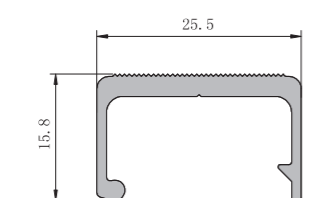
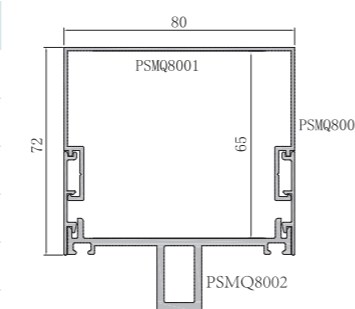
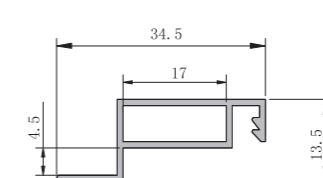
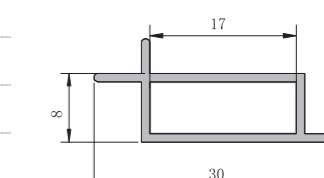
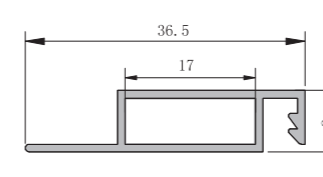
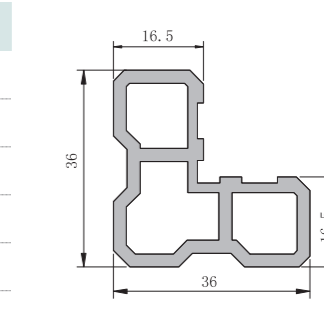
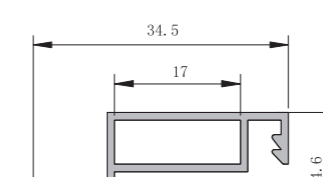
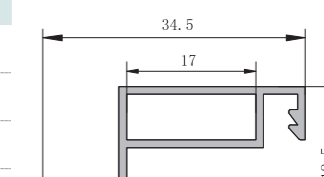
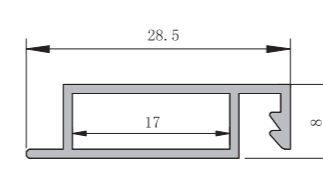
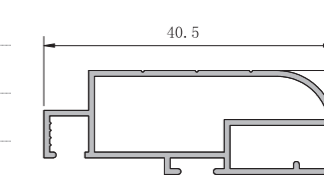
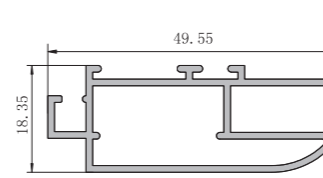
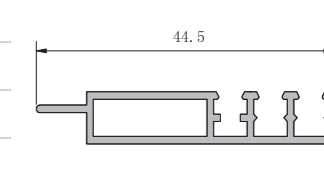

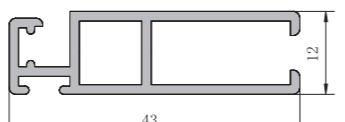
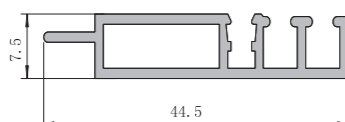
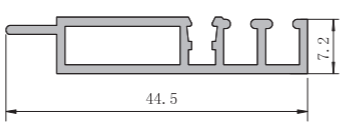
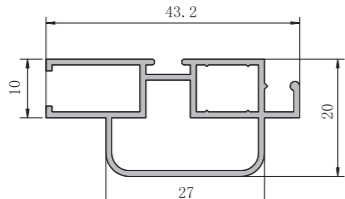
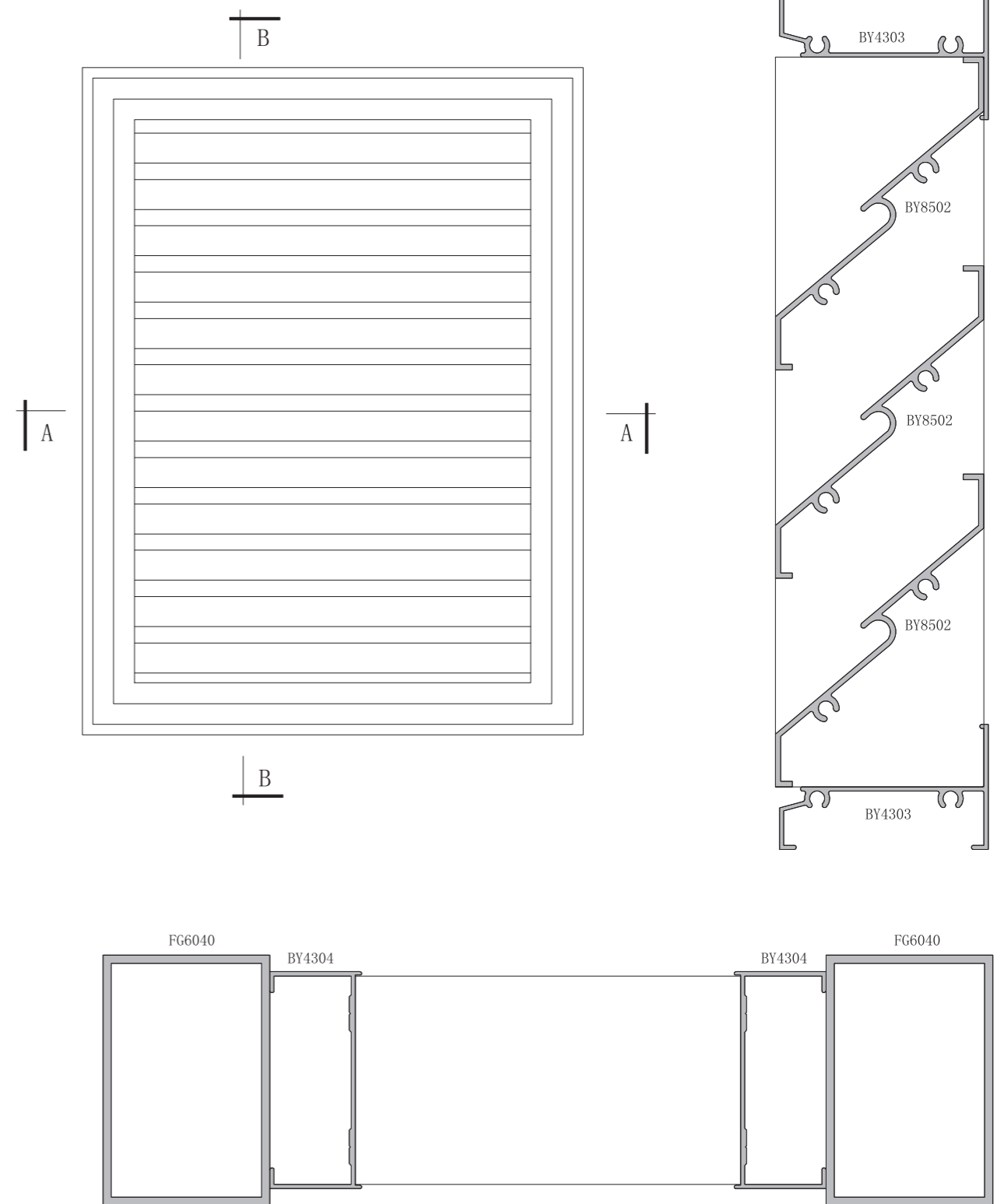
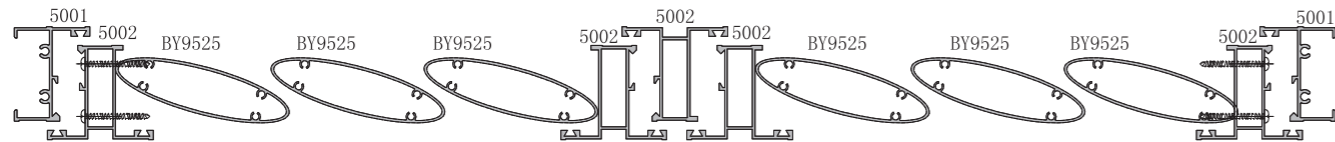
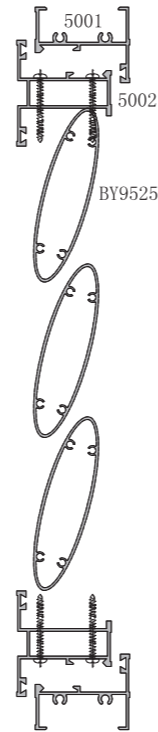
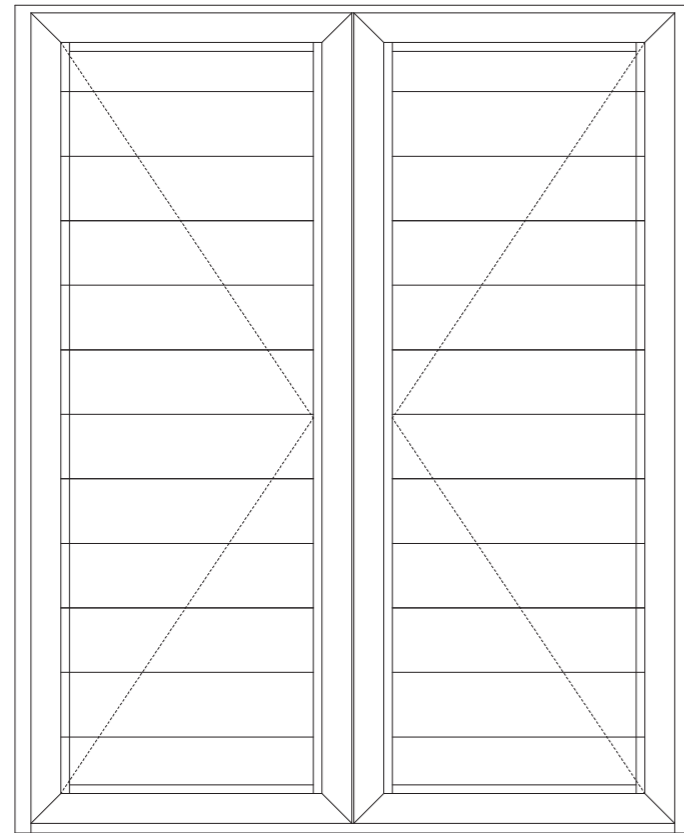

型号 Dwg NO.	BYC01
名称 Profile	百叶片
壁厚(mm) Thickness	重量(kg/m) Weight
0.8	0.180

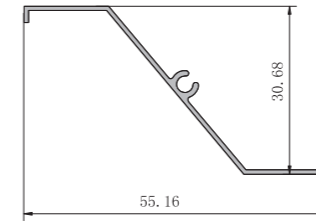

型号 Dwg NO.	BYC03
名称 Profile	百叶框
壁厚(mm) Thickness	重量(kg/m) Weight
1.0	0.162

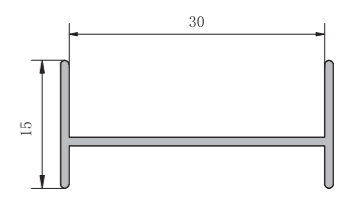

型号 Dwg NO.	BYC22
名称 Profile	百叶片
壁厚(mm) Thickness	重量(kg/m) Weight
1.0	0.267

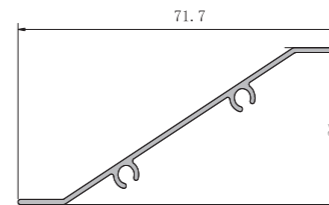

型号 Dwg NO.	BYC05
名称 Profile	百叶片
壁厚(mm) Thickness	重量(kg/m) Weight
0.7	0.172

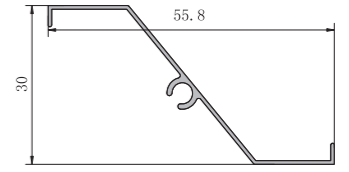

型号 Dwg NO.	BYC02
名称 Profile	百叶片
壁厚(mm) Thickness	重量(kg/m) Weight
1.2	0.322

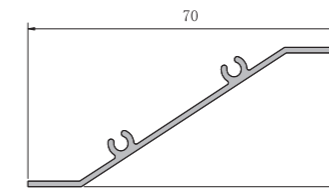

型号 Dwg NO.	BYC04
名称 Profile	百叶框
壁厚(mm) Thickness	重量(kg/m) Weight
1.0	0.22

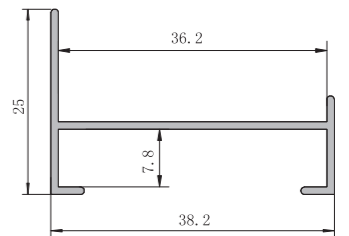

型号 Dwg NO.	BY8501
名称 Profile	百叶框
壁厚(mm) Thickness	重量(kg/m) Weight
2.0	0.841

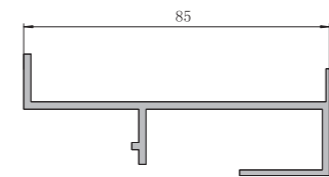

型号 Dwg NO.	BY8502
名称 Profile	百叶片
壁厚(mm) Thickness	重量(kg/m) Weight
1.3	0.464

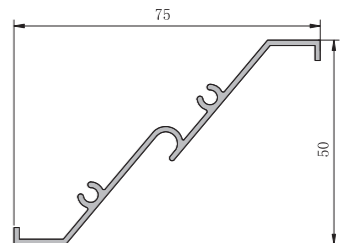

型号 Dwg NO.	BY8503
名称 Profile	百叶框
壁厚(mm) Thickness	重量(kg/m) Weight
1.5	0.396

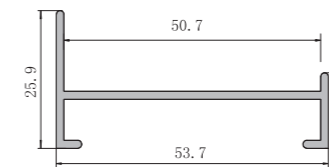

型号 Dwg NO.	3825
名称 Profile	方管
壁厚(mm) Thickness	重量(kg/m) Weight
1.0	0.396

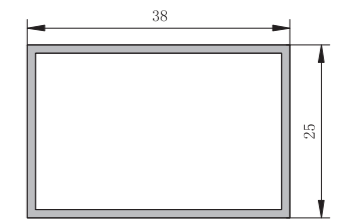

型号 Dwg NO.	50A38
名称 Profile	拼管
壁厚(mm) Thickness	重量(kg/m) Weight
1.0	0.19

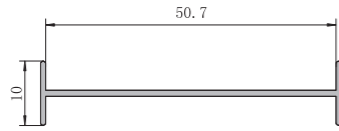

型号 Dwg NO.	BYC33
名称 Profile	百叶框
壁厚(mm) Thickness	重量(kg/m) Weight
1.0	0.17

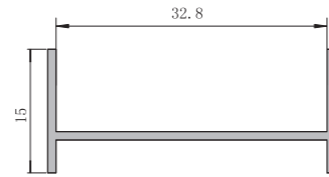

型号 Dwg NO.	HCMQ-08
名称 Profile	百叶框
壁厚(mm) Thickness	重量(kg/m) Weight
1.25	0.199

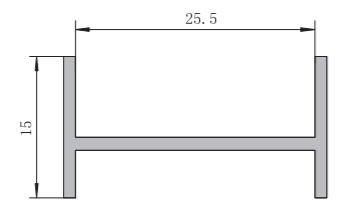

型号 Dwg NO.	BY4301
名称 Profile	百叶框
壁厚(mm) Thickness	重量(kg/m) Weight
1.0	0.425

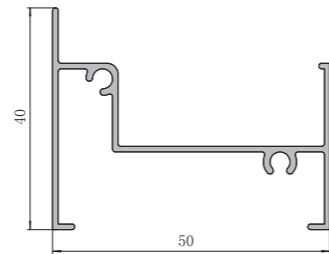

型号 Dwg NO.	BY4303
名称 Profile	百叶框
壁厚(mm) Thickness	重量(kg/m) Weight
1.0	0.319

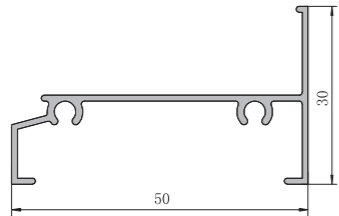

型号 Dwg NO.	HCMQ-09
名称 Profile	百叶片
壁厚(mm) Thickness	重量(kg/m) Weight
1.0	0.291

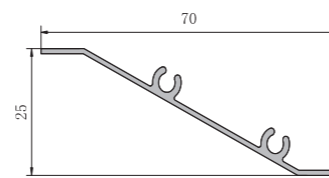

型号 Dwg NO.	BY4302
名称 Profile	百叶片
壁厚(mm) Thickness	重量(kg/m) Weight
0.9	0.279

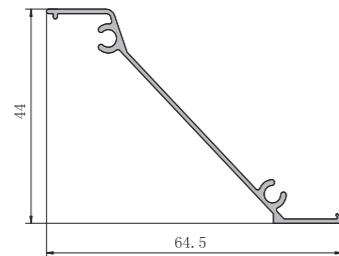

型号 Dwg NO.	BY4304
名称 Profile	百叶框
壁厚(mm) Thickness	重量(kg/m) Weight
1.0	0.297

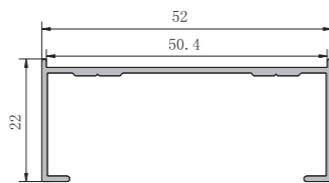

型号 Dwg NO.	BY01
名称 Profile	百叶框
壁厚(mm) Thickness	重量(kg/m) Weight
2.0	0.756

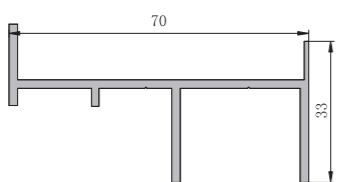

型号 Dwg NO.	BY02A
名称 Profile	百叶片
壁厚(mm) Thickness	重量(kg/m) Weight
1.3	0.437

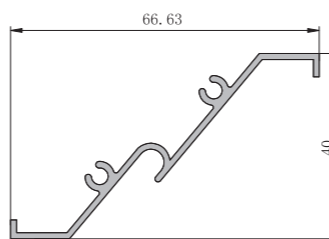

型号 Dwg NO.	BY7030A
名称 Profile	百叶片
壁厚(mm) Thickness	重量(kg/m) Weight
0.9	0.402

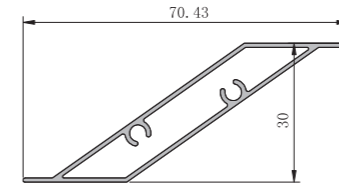

型号 Dwg NO.	BY02
名称 Profile	百叶框
壁厚(mm) Thickness	重量(kg/m) Weight
2.0	0.733

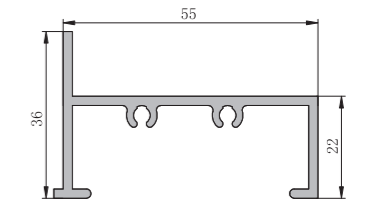

型号 Dwg NO.	BY03
名称 Profile	百叶框
壁厚(mm) Thickness	重量(kg/m) Weight
2.0	0.683

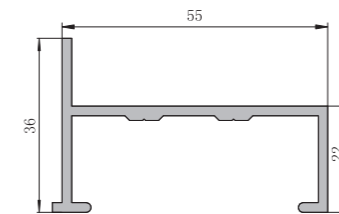

型号 Dwg NO.	BYP01
名称 Profile	百叶片
壁厚(mm) Thickness	重量(kg/m) Weight
0.8	0.207

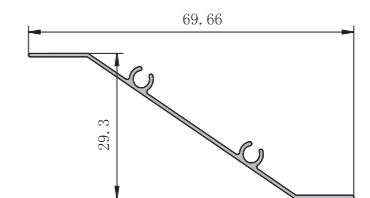

型号 Dwg NO.	BYC23
名称 Profile	横框
壁厚(mm) Thickness	重量(kg/m) Weight
1.2	0.306

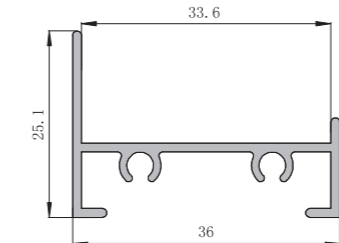

型号 Dwg NO.	BYC24
名称 Profile	竖框
壁厚(mm) Thickness	重量(kg/m) Weight
1.2	0.256

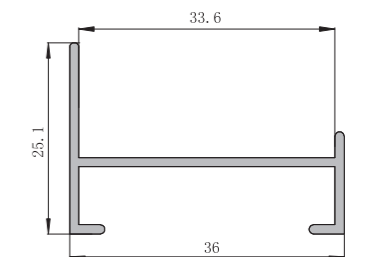

型号 Dwg NO.	DCBY004
名称 Profile	百叶
壁厚(mm) Thickness	重量(kg/m) Weight
0.95	0.233

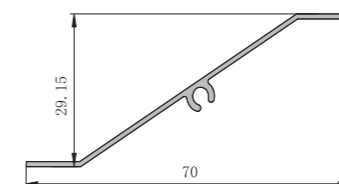

型号 Dwg NO.	DCBY005
名称 Profile	开启框
壁厚(mm) Thickness	重量(kg/m) Weight
1.2	0.389

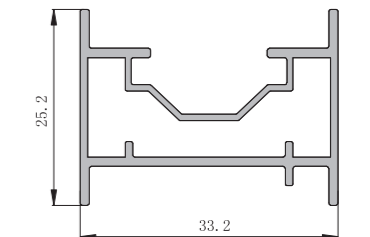

型号 Dwg NO.	DCBY006
名称 Profile	开启框
壁厚(mm) Thickness	重量(kg/m) Weight
1.2	0.379

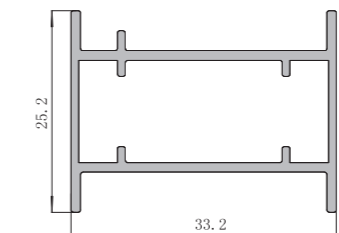

型号 Dwg NO.	DCBY007
名称 Profile	边框附件
壁厚(mm) Thickness	重量(kg/m) Weight
1.0	0.044

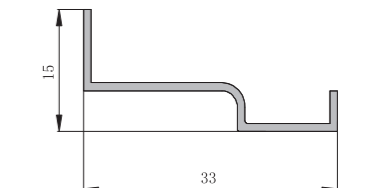

型号 Dwg NO.	BY9525
名称 Profile	百叶片
壁厚(mm) Thickness	重量(kg/m) Weight
1.5	0.83

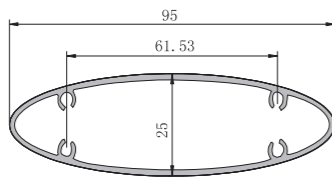

型号 Dwg NO.	2258
名称 Profile	百叶框
壁厚(mm) Thickness	重量(kg/m) Weight
1.2	0.233

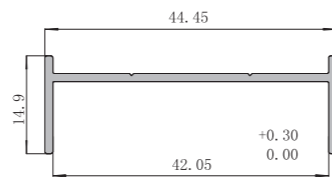

型号 Dwg NO.	BYC33
名称 Profile	百叶框
壁厚(mm) Thickness	重量(kg/m) Weight
1.0	0.17

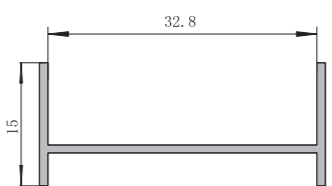

型号 Dwg NO.	BYC34
名称 Profile	百叶片
壁厚(mm) Thickness	重量(kg/m) Weight
1.0	0.321

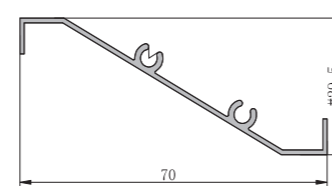

型号 Dwg NO.	2205-1.1
名称 Profile	百叶框
壁厚(mm) Thickness	重量(kg/m) Weight
1.1	0.417

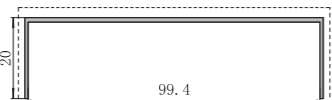

型号 Dwg NO.	BYK501
名称 Profile	百叶框
壁厚(mm) Thickness	重量(kg/m) Weight
1.5	0.513

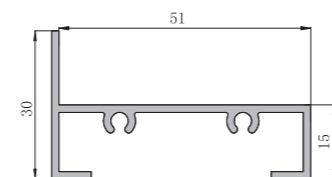

型号 Dwg NO.	E5195
名称 Profile	百叶框
壁厚(mm) Thickness	重量(kg/m) Weight
1.2	0.228

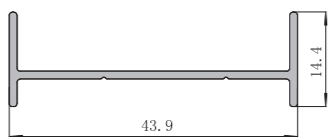

型号 Dwg NO.	MF29
名称 Profile	百叶片
壁厚(mm) Thickness	重量(kg/m) Weight
1.8	0.576

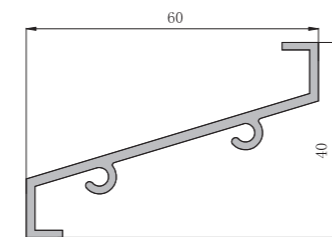

型号 Dwg NO.	BYK502
名称 Profile	百叶框
壁厚(mm) Thickness	重量(kg/m) Weight
1.5	0.447

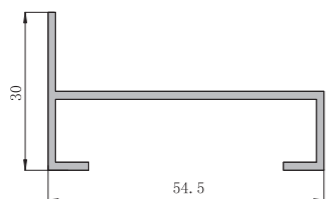

型号 Dwg NO.	E5772
名称 Profile	百叶片
壁厚(mm) Thickness	重量(kg/m) Weight
1.2	0.393

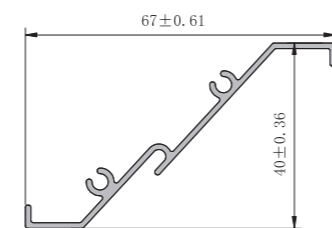

型号 Dwg NO.	JHBY
名称 Profile	百叶片
壁厚(mm) Thickness	重量(kg/m) Weight
1.1	0.327

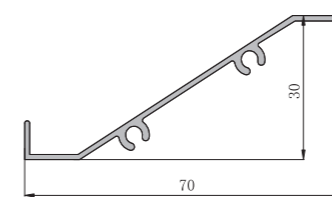

型号 Dwg NO.	HL2011
名称 Profile	百叶框
壁厚(mm) Thickness	重量(kg/m) Weight
2.0	0.73

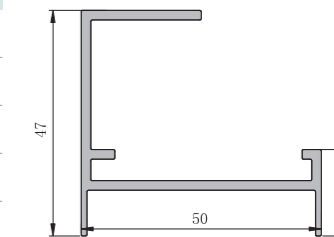

型号 Dwg NO.	NA01-07
名称 Profile	百叶框
壁厚(mm) Thickness	重量(kg/m) Weight
1.55	0.284

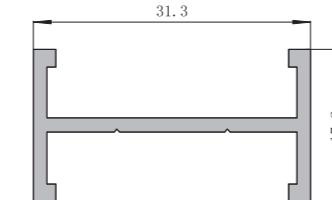

型号 Dwg NO.	NA01-08
名称 Profile	百叶片
壁厚(mm) Thickness	重量(kg/m) Weight
0.7	0.267

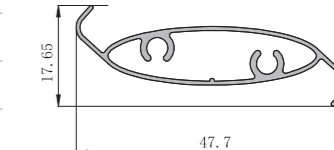

型号 Dwg NO.	HL2012
名称 Profile	百叶框
壁厚(mm) Thickness	重量(kg/m) Weight
2.0	0.81

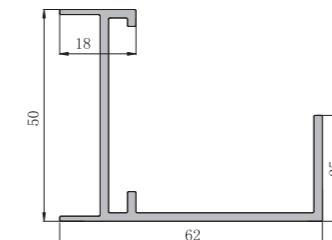

型号 Dwg NO.	HL2013
名称 Profile	百叶片
壁厚(mm) Thickness	重量(kg/m) Weight
1.4	0.47

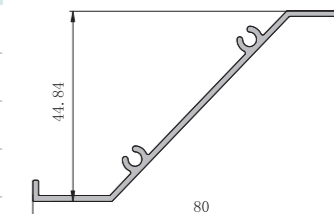

型号 Dwg NO.	YC004
名称 Profile	百叶片
壁厚(mm) Thickness	重量(kg/m) Weight
1.1	0.374

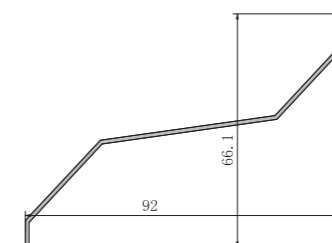

型号 Dwg NO.	MQ-BYK-01
名称 Profile	百叶框
壁厚(mm) Thickness	重量(kg/m) Weight
2.0	0.778

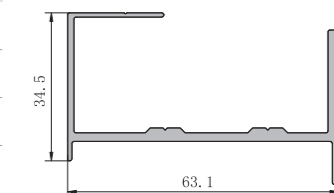

型号 Dwg NO.	SDL2756
名称 Profile	百叶框
壁厚(mm) Thickness	重量(kg/m) Weight
1.2	0.209

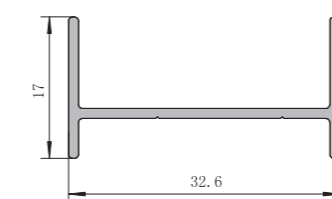

型号 Dwg NO.	SDL3768
名称 Profile	百叶片
壁厚(mm) Thickness	重量(kg/m) Weight
1.0	0.369

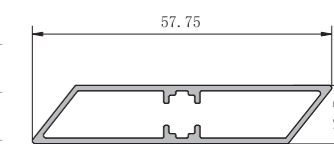

型号 Dwg NO.	MQ-BYK-02
名称 Profile	百叶框
壁厚(mm) Thickness	重量(kg/m) Weight
2.0	0.89

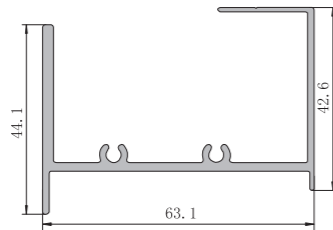

型号 Dwg NO.	SDL2757
名称 Profile	百叶片
壁厚(mm) Thickness	重量(kg/m) Weight
1.2	0.321

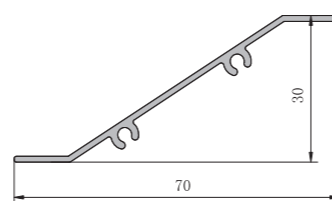

型号 Dwg NO.	BY5080
名称 Profile	百叶片
壁厚(mm) Thickness	重量(kg/m) Weight
1.2	0.44

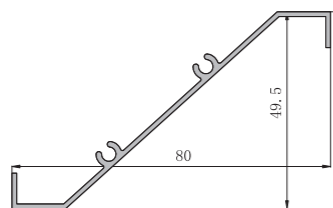

型号 Dwg NO.	BY100X100
名称 Profile	百叶片
壁厚(mm) Thickness	重量(kg/m) Weight
3.0	1.591

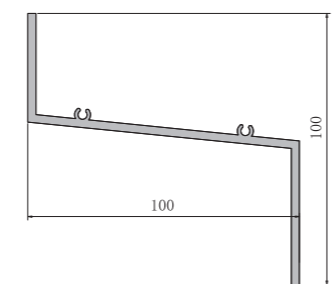

型号 Dwg NO.	CL100X50
名称 Profile	百叶框
壁厚(mm) Thickness	重量(kg/m) Weight
2.0	1.091

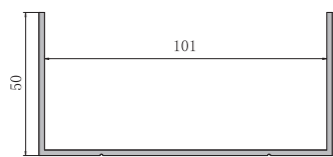

型号 Dwg NO.	BYC11
名称 Profile	百叶
壁厚(mm) Thickness	重量(kg/m) Weight
2.0	0.799

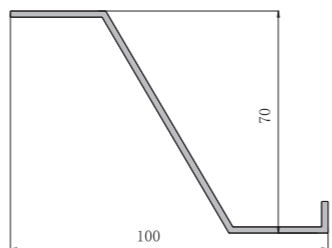

型号 Dwg NO.	ZSBYP
名称 Profile	百叶片
壁厚(mm) Thickness	重量(kg/m) Weight
1.8	1.815

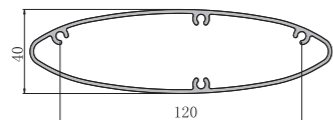

型号 Dwg NO.	2259
名称 Profile	百叶片
壁厚(mm) Thickness	重量(kg/m) Weight
1.2	0.485

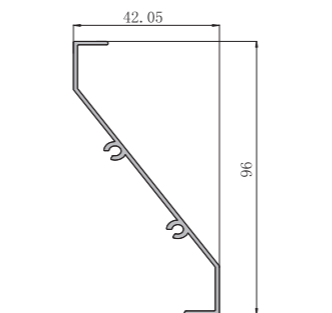

型号 Dwg NO.	2204
名称 Profile	百叶片
壁厚(mm) Thickness	重量(kg/m) Weight
1.1	0.454

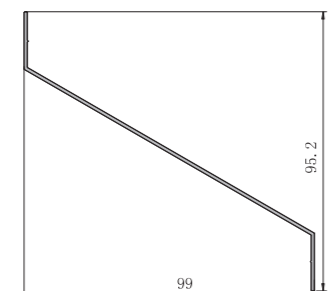

型号 Dwg NO.	2263-0.8
名称 Profile	百叶片
壁厚(mm) Thickness	重量(kg/m) Weight
0.8	0.098

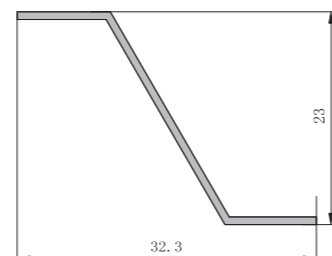

型号 Dwg NO.	2210-1.05
名称 Profile	百叶片
壁厚(mm) Thickness	重量(kg/m) Weight
1.05	0.188

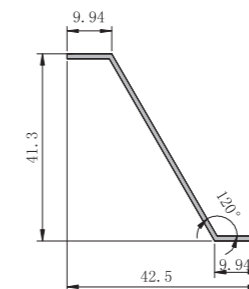

型号 Dwg NO.	BYC03-0.8
名称 Profile	百叶框
壁厚(mm) Thickness	重量(kg/m) Weight
0.8	0.134

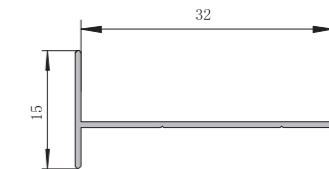

型号 Dwg NO.	BYP01-0.7
名称 Profile	百叶片
壁厚(mm) Thickness	重量(kg/m) Weight
0.7	0.188

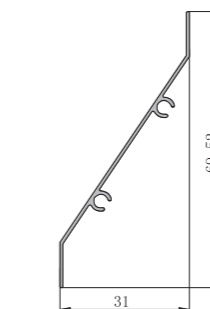

型号 Dwg NO.	
名称 Profile	
壁厚(mm) Thickness	重量(kg/m) Weight

型号 Dwg NO.	
名称 Profile	
壁厚(mm) Thickness	重量(kg/m) Weight

型号 Dwg NO.	
名称 Profile	
壁厚(mm) Thickness	重量(kg/m) Weight

型号 Dwg NO.	
名称 Profile	
壁厚(mm) Thickness	重量(kg/m) Weight

型号 Dwg NO.	
名称 Profile	
壁厚(mm) Thickness	重量(kg/m) Weight

型号 Dwg NO.	
名称 Profile	
壁厚(mm) Thickness	重量(kg/m) Weight

型号 Dwg NO.	
名称 Profile	
壁厚(mm) Thickness	重量(kg/m) Weight

型材型号	模具名称	开模壁厚	理论米重
12.7X12.7	12.7X12.7	1.27	0.157
HW190117	12.7x12.7	1.6	0.191
FP0600-050	15.1x15.1	1.1	0.167
FC200	15X15	1.2	0.18
FG15.5	15.5x15.5	0.8	0.127
FG155A	15.55X15.55	1.0	0.158
		1.1	0.173
		1.2	0.187
CIA-E025	15.88x15.88	1.4	0.213
FG18X8	18x8	0.8	0.106
VFT7575-050	18.7x18.7	0.6	0.138
FST7575-035	18.7x18.7	0.9	0.155
FG1818	18.7x18.7	1.0	0.192
FHT1575-060	18.7x18.7	1.4	0.263
UFA07512-050	19.05x12.7	1.3	0.198
QP30	20x10	2.0	0.283
BH201	20x20	1.0	0.206
20X20X1.2	20x20	1.2	0.245
NA-008	20x20	1.7	0.323
NA2020C	20x20	1.7	0.847
20x20x2.0	20x20	2.0	0.392
SF07	20.5x11.1	0.6	0.099
XCPL020	21x21	2.5	0.503
BGL-XC06	22X20	2.5	0.503
FG25X10	25x10	0.8	0.145
YL-14	25X15	1.0	0.207
FG25X25X1.3	25x25	1.3	0.335
2525	25x25	0.65	0.172
		0.9	0.236
		1.0	0.261
		1.1	0.286

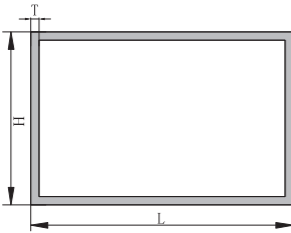

DCFG25X25	25x25	1.5	0.384
FQ1010-080	25x25	1.8	0.454
62488	25.4x25.4	0.9	0.24
HDCD043	25.4x25.4	1.0	0.266
FG26.6X19.8-1.0	26.6x19.8	1.0	0.242
LM8213	28x22	1.2	0.35
FG28.5X20.2	28.5x20.2	1.0	0.353
HQY030912	33X22	1.2	0.343
FDP02	30x24.2	0.9	0.273
FG3030	30x30	0.9	0.315
FG30X30X1.3	30x30	1.2	0.406
DK-010	30x30	2.0	0.609
YT0029-03	30.3x30.3	1.9	0.891
SF06	30.5x15.8	0.6	0.147
QL11154	31.8x31.8	1.1	0.368
FG3213	32x13	1.5	0.342
ER09	32x32	1.0	0.337
NT-09	34.5X21.5	2.0	0.548
ZJ-03	35x30	1.5	0.548
FG35X35	35X35	1.0	0.506
VP02	37X18	1.1	0.369
FV1558-050	37.8x15.55	0.9	0.316
FH1575-045	37.8x18.7	0.9	0.268
FC1510-080	37.8x25	2.0	0.637
3825	38X25	0.8	0.267
		1.0	0.332
		1.2	0.396
XMPE315	38x38	0.8	0.321
TQ013	38x38	1.1	0.442
62515	38.1x19.05	0.9	0.271
ER06	38.1x38.1	1.0	0.39
XMPE189	38.1X38.1	1.2	0.478

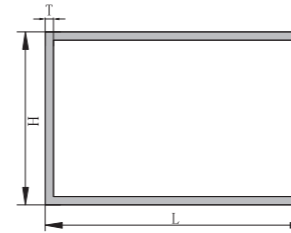

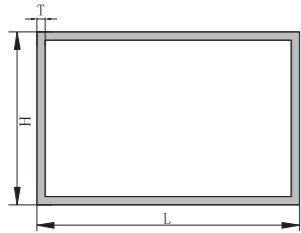

FG39X38-4	39X38	4.0	1.5
CKAQ041D	39.15x39.15	0.8	0.331
FG4014	40x14	0.8	0.228
BG20X40X0.9	40x20	0.9	0.344
KM4020	40X20	1.2	0.28
BG2040	40x20	1.8	0.34
DK-009	40x20	2.0	0.528
GZ004	40x20.2	1.0	0.353
GN7021	40x40	0.8	0.376
SD37	40x40	0.9	0.609
FX023	40x40	1.0	0.424
VP01	40x40	1.2	0.507
BG40X40X1.3	40X40	1.3	0.547
4040X2	40x40	2.0	0.808
FG41A	40.8x40.8	2.9	0.473
PQ1625-090	40.82x40.82	2.0	0.844
FG4447	47X44	1.2	0.58
A13	44.5x44.5	0.9	1.129
726-1.0	44.45x44.45	1.0	0.472
CN-078-2	44.5x44.5	1.1	0.519
726-1.3	44.45x44.45	1.3	0.61
A-1931	44.45x44.45	1.5	0.696
FG2845	45X28	1.2	0.46
FG4545	45x45	1.0	0.479
TSK4503	45x45	1.4	0.662
4545	45x45	1.5	0.63
P011818-125	46x46	2.8	0.704
KT-VT196	47x27	0.9	1.307
KT-VT196	47x27	0.9	0.339
BH0250Y	50X13	1.2	0.339
DK-034	50x15	2.0	0.396
DCFG50X20	50x20	1.5	0.664

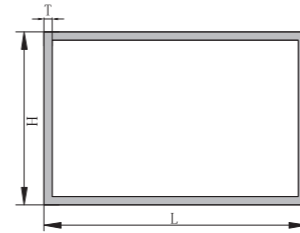

			0.7	0.280
			1.0	0.397
			1.1	0.436
			1.2	0.474
			1.4	0.55
			2.0	0.772
			3.4	1.261
5025	50X25			
FG5030	50x30	1.1	0.547	
FG5035	50x35	1.2	0.54	
FG5047	50x47.2	1.4	0.719	
			1.0	0.533
			1.3	0.689
			1.5	0.792
			1.7	0.893
			2.0	1.044
			3.0	4.534
5050	50X50			
82521	50.8x25.4	0.8	0.325	
NG2179	50.8x25.4	0.9	0.404	
YA-10	50.8x25.4	1.0	0.404	
A-37	50.8x25.4	1.1	0.478	
HW190103	50.8x25.4	3.25	1.22	
HW190109	50.8x38.1	3.25	1.446	
NG2458	50.8x50.8	1.5	0.801	
QL11156	51x51	1.4	0.756	
FG5545	55x45	1.0	0.529	
FG5550	55X50	1.4	0.78	
H4854	55.2X24.2	1.4	0.601	
56X65X2.0	56x65	2.0	1.273	
POC2222-125	56.56x56.56	2.8	1.626	
KLT-13013	57.4x16.5	1.2	0.467	
FG58X30	58x30	2.0	0.914	
IAB003	60x12	1.2	0.454	

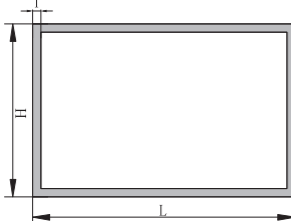

BG60X30	60x30	1.2	0.572
FG6040	60X40	2.0	1.04
6040	60X40	3.0	1.534
FG6060	60x60	1.0	0.624
6060-2	60x60	2.0	1.262
FG6262A	62.8X62.8	2.8	1.814
FG6262B	62.8x62.8	1.7	1.137
CA03-05	64x64	3.2	1.971
SFFG6520	65X20	1.4	0.626
SFFG6550	65x50	1.4	0.854
BG6560	65x60	2.0	1.316
6565	65x65	1.0	0.696
FG70X20-1.0	70X20	1.0	0.479
FG7025	70x25	1.1	0.506
BH271	75x25	1.2	0.637
HW190104	75X75	2.0	1.557
7625	76x25	1.0	0.539
		1.2	0.644
		1.5	0.8
7638	76x38	1.0	0.609
ER47	76x38	1.2	0.728
XN-11493	76x38	2.2	1.311
7644	76X44	0.8	0.515
		0.9	0.579
		1.0	0.642
		1.1	0.705
		1.2	0.768
		1.3	0.83
		1.4	0.893
		1.5	0.955
		1.6	1.02
		1.7	1.08
		2.0	1.26
2.5	1.564		
3.0	1.86		

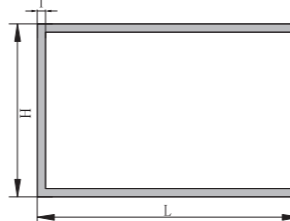

76x76	76x76	0.9	0.735
		1.2	0.977
		1.3	1.057
		1.9	1.532
H10495	76X76	2.0	1.61
FX003	76.2x25.4	0.9	0.489
DIS-603L	76.2x25.4	2.1	1.105
FX004	76.2x44.45	1.0	0.645
823-1.15	76.2x44.45	1.15	0.74
HW190105	76.2x50.8	3.25	2.115
FG76.2X76.2	76.2x76.2	3.0	2.39
DN116	80x16	1.2	0.603
QA13	80x20	1.5	0.792
DK-012	80x20	2.0	1.044
SD34	80x40	0.9	0.515
QC-001	80x40	1.1	0.705
FG8040	80x40	1.2	0.954
CK40X80X1.3	80x40	1.3	0.825
8044	80x44	0.9	0.598
		1.0	0.664
		1.2	0.794
8044	80x44	1.4	0.923
		2.0	1.48
		2.0	1.7
GR8060	80x60	2.0	1.48
8080H	80x80	1.3	1.029
		2.0	1.7
BH-0256	80.3x40	1.2	0.77
H09670	82X31	1.8	1.069
XMPE194	82.5x38	0.8	0.836
XMPE176	82.5x38.1	0.85	0.546
XMPE030	82.5X38.1	1.0	0.64
86.5X54.5	86.5X54.5	2.5	1.8
8744	87x44	1.0	0.701

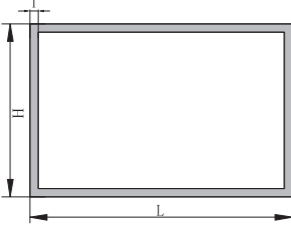

9044	90x44	1.0	0.718
		1.1	0.789
		1.4	0.999
		1.5	1.069
DCFG95X25	95X25	2.0	1.262
XDT-08	92.5x42.5	2.0	1.38
G10020A	100x20	0.8	0.511
FG100X20-1.0	100X20	1.0	0.642
DK-033	100x20	3.0	1.861
10025	100x25	0.9	0.603
		1.0	0.669
		1.2	0.8
FG10025	100x25	2.0	1.312
100X40X1.1	100x40	1.1	0.63
BH-0258	100x40	1.2	0.897
FG100X40-2.0	100x40	2.0	1.48
DCFG100X40	100X40	2.5	1.836
1044	100X44	1.0	0.772
		1.1	0.849
		1.2	0.924
		1.5	1.15
1.8	1.37		
AF0090	100x45	1.3	0.997
FG100X50X1.4	100x50	1.4	1.121
BH260	100x50	1.5	1.2
ALL100X50	100x50	1.8	1.511
BH261	100x50	2.0	1.597
W136-1	100x50	2.1	1.666
KDJ35	100x50	2.8	2.198
100X60	100x60	2.0	1.7
FG10060-2.8	100x60	2.8	2.35
FG10065	100x65	1.5	1.32

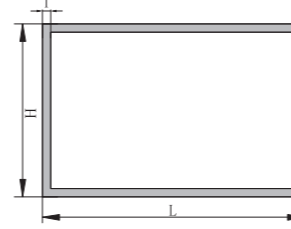

10F10	100X100	1.3	1.396
		1.4	1.502
		1.5	1.61
		2.0	2.13
VA100X100X5	100x100	5.0	3.166
HDCD-228	101.6X25.4	1.1	0.813
HDCD076	101.6x44.5	1.2	0.938
831-1.45	101.6x25.4	1.45	0.979
HW190102	101.6x25.4	3.25	2.115
837-1.35	101.6x44.45	1.35	1.053
831-1.45	101.6x25.4	1.45	0.979
YA-11	101.6x50.8	1.6	1.299
HW190107	101.6x50.8	3.25	2.561
FG1010A	100.6x100.6	2.9	2.95
A11	102x44.5	1.1	0.863
M4690	102.5x102.5	2.0	2.187
FG11065	110x65	2.0	1.86
051866L	120x30	1.5	1.2
FG120X40-1.6	120x40	1.6	1.365
AF0160	120x45	1.3	1.14
FG12050	120x50	1.3	1.184
FG120	120x120	3.5	4.436
133X60X3.0	133x60	3.0	3.052
YL20041	140x140	3.2	4.74
BG150X16	150x16	1.4	1.33
FG150X50	150x50	1.8	1.923
H2961	150X50	2.2	2.385
DCFG150X60	150X60	1.5	1.689
FG150X55	150x56.4	1.85	2.04
DN112	150x150	3.5	5.444
180X50	180X50	2.5	3.06
FG75200	200x75	2.8	3.672
FG200X100-3.0	200X100	3.0	4.8

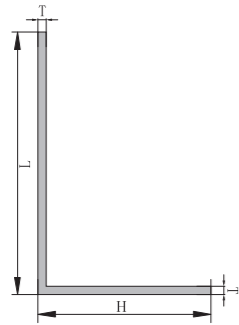

型号	长度LXH	米重kg/m	壁厚T
JL9X7	9x7	0.076	2.0
CKA-10	10x10	0.052	1.0
XMPE299	10x10	0.0365	0.7
BH130	12x6	0.046	1.0
MP113	12x10	0.083	1.5
204-1.0	12.7X12.7	0.066	1.0
XMPE077	12.7X24	0.196	2.1
312-0.8	12.7x31.75	0.095	0.80
CKA13	13x13	0.068	1.0
CKA15	15x15	0.079	1.0
ACS022	15x15	0.116	1.5
YA-16	15.5x15.5	0.081	1.0
207-0.85	15.875X15.875	0.071	0.85
XMPE255	17x17	0.067	0.75
CKA17	17x17	0.09	1.0
CKMA131	17x17	0.098	1.1
AG17X17X1.3	17x17	0.115	1.3
HDCD048	19x19	0.139	1.4
ES019-K1	19x19	0.075	2.5
11033	19.05x19.05	0.082	0.8
HW190100	19.05x19.05	0.3	3.175
YA-17	19.6x19.6	0.124	1.2
BH131	20x6	0.068	1.0
BH0132	20x10	0.083	1.05
QP31	20x10	0.152	2.0
JL20X15X1.5	20x15	0.137	1.5
JL2020	20x20	0	2.0
GM-YLK-26	20x20	0.074	0.7
CKGT143	20x20	0.085	0.8
CKA20	20x20	0.106	1.0
BH0105	20x20	0.111	1.05
QP32	20x20	0.157	1.5
JL20X40X1.5	20x40	0.239	1.5
QA22	20x40	0.315	2.0
BH0134	25x12	0.098	1.0
CKA25-1	25x25	0.133	1.0
XO-0086	25x25	0.196	1.5
NK0032	25x25	0.21	1.6
222-0.85	25.4X25.4	0.115	0.85
0225A	25.4X25.4	0.2	1.5
NG2081	25.4x25.4	0.214	1.6
0225B	25.4X25.4	0.265	2.0
HW180121	25.4x25.4	0.412	3.18
JL1727	27x17	0.207	1.8
BH0135	32x12	0.123	1.05
YL09	30x15	0.15	1.2
JL3020	30x20	0.198	1.5
		0.261	2.0
		0.384	3.0
YLK-17	30x30	0.112	0.7

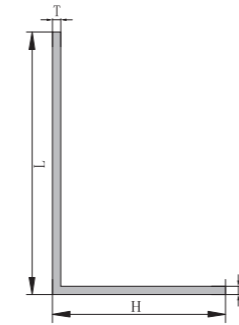

型号	长度LXH	米重kg/m	壁厚T
CKA30301	30x30	0.16	1.0
JL3030-1.5	30x30	0.239	1.5
DK-007	30x30	0.316	2.0
J3030	30x30	0.46	3.0
CKA30X30X3.1	30X30	0.48	3.1
JZ06	30x30	0.523	3.4
A30X40X1.5	30X40	0.279	1.5
A30X50X1.5	30X50	0.319	1.5
A30X50X4	30X50	0.824	4.0
BH0107	32x32	0.272	1.6
BH107	32x32	0.337	2.0
CKA32-2.8	32x32	0.466	2.8
CKA32-4	32x32	0.65	4.0
MQ98JL	32.9x7	0.204	2.0
YR86	35x20	0.22	1.5
JL3520-4	35x20	0.555	4.0
00014	37.5x37.5	0.587	2.5
YR63	37.8x13.8	0.11	0.8
JL3825	38x25	0.332	2.0
		0.49	3.0
JL38X25.4X2.0	38x25.4	0.334	2.0
HW180122	38.1x25.4	0.522	3.18
JL3838	38x38	0.596	1.0
HDCD1210	38.1X38.1	0.631	3.18
HW180123	38.1x38.1	0.632	3.18
PK007	38X38	0.402	2.0
CKA38-3.5	38x38	0.69	3.5
QL01314	38x38	0.875	4.5
JL45X20	45x20	0.242	1.4
PSMQ4025	40x25	0.664	4.0
KLT-YGF11020	40x27	0.653	3.8
YLK-18	40x40	0.192	0.9
FC109	40x40	0.236	1.1
JL40X40X1.2	40x40	0.257	1.2
J4040-1.8	40x40	0.376	1.82
JL40X40	40x40	0.633	2.1
JL4040	40x40	0.628	3.0
JL4040-4.0	40x40	0.827	4.0
HW190097	44.45x44.45	0	3.175
JL5015	50x15	0.506	3.0
TR-N006	50x20	0.37	2.0
ACS024	50x25	0.26	1.3
JL5525	55x25	0.424	2.0
HW190010	51x30	0.322	1.5
DK-035	50x30	0.424	2.0
DK-036	50x30	0.629	3.0
JL5035-5	50x35	1.088	5.0
YLK-09	50x50	0.241	0.9
FC110	50X50	0.295	1.1
BH110	50x50	0.348	1.3

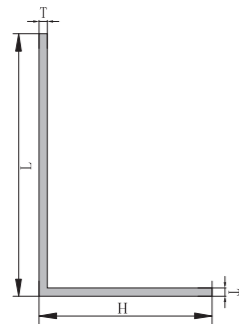

型号	长度LXH	米重kg/m	壁厚T
JL50X50X1.8	50x50	0.481	1.8
JL5050	50x50	0.791	3.0
5050L	50x50	1.169	4.5
BEL-2126	50.1x50.1	1.621	6.35
KSF-358A	50.8x25.4	0.299	1.4
HW190111	50.8x25.4	0.32	1.59
BH137-25	50.8x25.4	0.501	2.5
BH137	50.8x25.4	0.597	3.0
HW180124	50.8x25.4	0.632	3.18
HW190101	50.8x38.1	0.703	3.175
HW180125	50.8x50.8	1.254	4.76
JL-01	55x30	0.706	3.0
BR-2006	60x15	0.397	2.0
RG02-01	60x18	0.611	3.0
DK-001	60x40	0.792	3.0
HDCD1208	76.2x50.8	1.069	3.18
HDCD1209	76.2x50.8	2.084	6.35
QA21	80x20	0.534	2.0
DK-002	80x40	1.262	4.0
QA20	100x20	0.642	2.0
YSH1117	100x100	1.606	3.0
HW190108	101.6x76.2	0	6.35

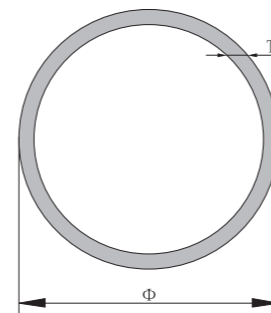

型材型号	模具尺寸	壁厚T	米重Kg/m
YG8X2	φ8	2.0	0.103
SF05	φ10.8	0.6	0.052
YG11X1.25	φ11	1.2	0.104
DCYG18	φ18	1.2	0.172
SF04	φ18.6	0.6	0.092
YG19	φ19	0.7	0.109
		0.8	0.124
		1.0	0.154
		1.2	0.183
YG19A	φ19	1.1	0.167
YG22	φ22	0.7	0.127
		0.8	0.145
		1.0	0.179
YG22.1x1.2	φ22.1	1.14	0.239
SF03	φ25	0.6	0.125
YG25X1.1	φ25	1.1	0.225
YG26X7.75	φ26	7.7	1.208
YG24X7	φ27	7.0	1.016
YG27.7X2.0	φ27.7	2.03	0.439
YG30X1.75	φ30	1.7	0.475
DK-015	φ32	1.5	0.391
HW190069	φ38.1	2.56	2.642
HDCD245	φ40	1.5	0.545
AMA402	φ40	1.98	0.649
BEL-2261	φ48.1	2.93	1.156
YG43X4.5	φ43	4.5	1.48
HW190112	φ50.8	1.48	0.678
TR-YG60	φ60	1.5	0.75
AMA703	φ70	2.93	1.718
BZ2410	φ86.5	2.0	1.444
A-10-395	φ92.4	1.8	0.711
D095	φ96.6	2.4	2.01
D102	φ102.5	2.8	2.385