

型号 Dwg NO.	GR110M01
名称 Profile	门框
壁厚(mm) Thickness	重量(kg/m) Weight
2.0	2.211

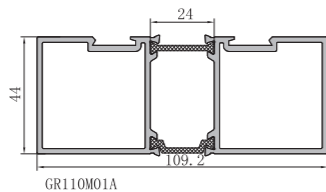

型号 Dwg NO.	GR110M02
名称 Profile	上方
壁厚(mm) Thickness	重量(kg/m) Weight
2.0	1.868

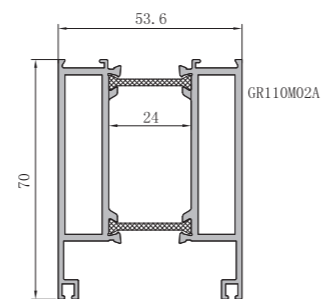

型号 Dwg NO.	GR110M03
名称 Profile	下方
壁厚(mm) Thickness	重量(kg/m) Weight
2.0	2.01

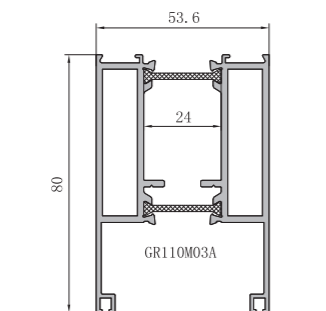

型号 Dwg NO.	GR110M04
名称 Profile	光企
壁厚(mm) Thickness	重量(kg/m) Weight
2.0	2.258

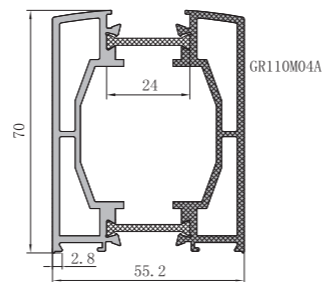

型号 Dwg NO.	GR110M05
名称 Profile	压线
壁厚(mm) Thickness	重量(kg/m) Weight
0.9	0.11

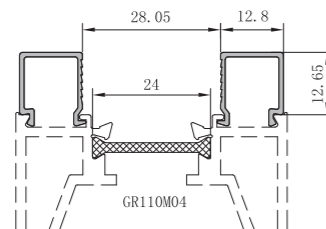

型号 Dwg NO.	
名称 Profile	
壁厚(mm) Thickness	重量(kg/m) Weight

型号 Dwg NO.	
名称 Profile	
壁厚(mm) Thickness	重量(kg/m) Weight

型号 Dwg NO.	
名称 Profile	
壁厚(mm) Thickness	重量(kg/m) Weight

型号 Dwg NO.	
名称 Profile	
壁厚(mm) Thickness	重量(kg/m) Weight

型号 Dwg NO.	
名称 Profile	
壁厚(mm) Thickness	重量(kg/m) Weight

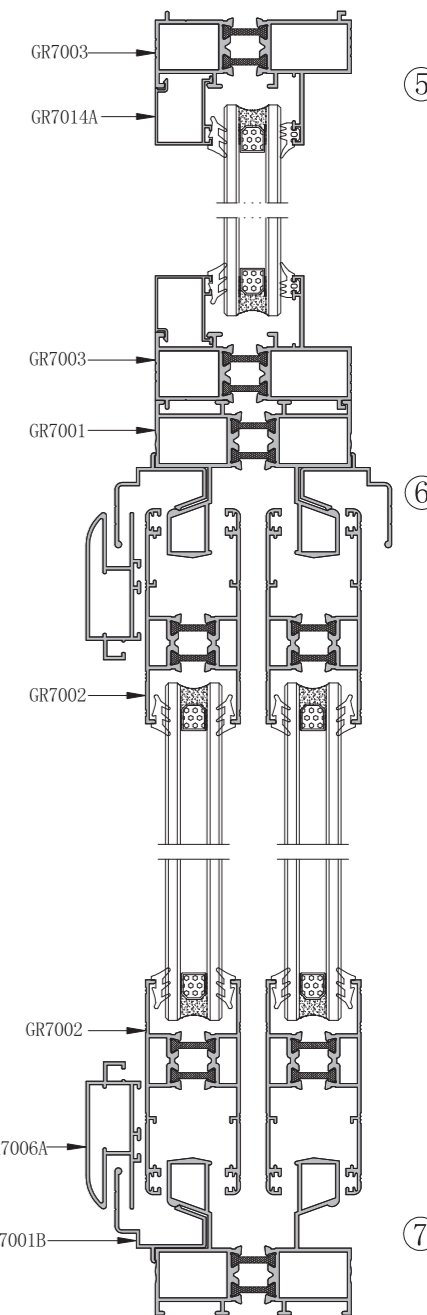
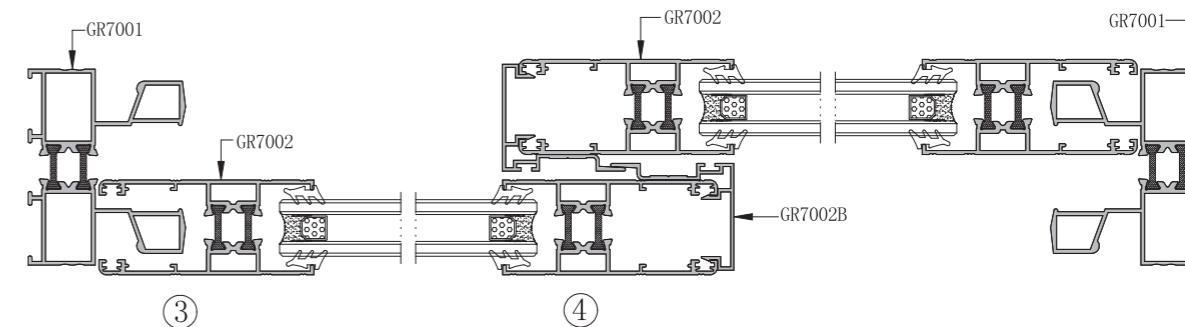
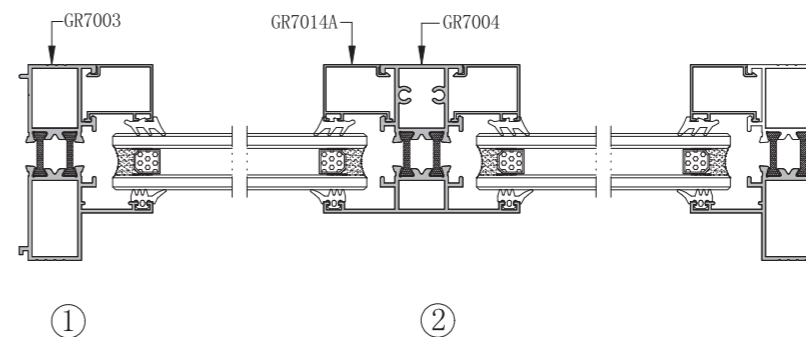
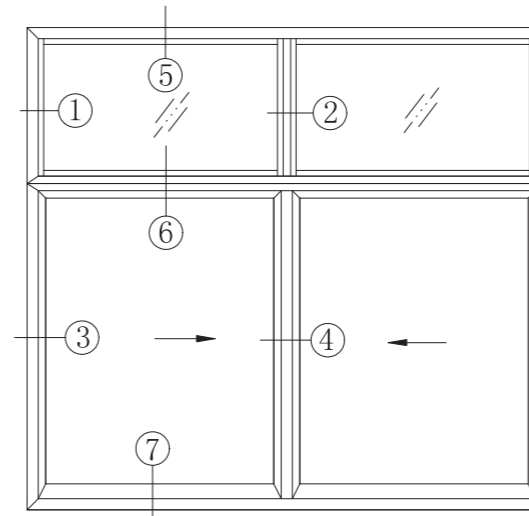

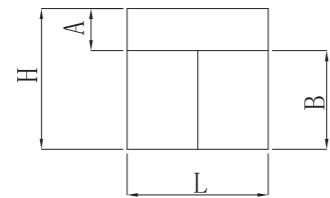

H=1500mm
L=1500mm
A=500mm
B=1000mm

用料清单 (仅供参考)

名称	型号	公式	长度 (mm)	每米重量	数量	重量(kg)
横固定窗框	GR7003	L	1500	1.041	1	1.56
竖固定窗框	GR7003	A	500	1.040	2	1.04
固定窗横压线	GR7014A	L-45.8	1454.20	0.161	2	0.47
固定窗竖压线	GR7014A	A-84	416	0.161	2	0.13
上滑	GR7001	L	1500	1.438	1	2.16
披水板	GR7001B	L-45.2	1454.80	0.255	1	0.37
下滑	GR7001	L	1500	1.442	1	2.16
边封	GR7003	B	1000	1.041	2	2.08
光企	GR7002	B90	910	1.066	2	1.94
勾企	GR7002+GR7002B	B-90	910	1.428	2	2.60
上方	GR7002	L/2-84	666	1.066	2	1.42
下方	GR7002	L/2-84	666	1.066	2	1.42
				0.000		
合计 (kg)						17.36
铝窗面积	宽1.5米		高1.5米		2.25m ²	
单位重量	17.36/2.25=7.72kg/m ²					

型号 Dwg NO.	GR7001
名称 Profile	推拉框
壁厚(mm) Thickness	重量(kg/m) Weight
1.3	1.442

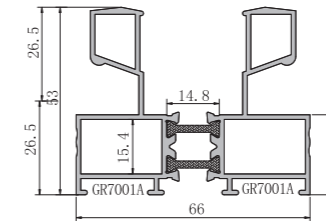

型号 Dwg NO.	GR7003
名称 Profile	固定框
壁厚(mm) Thickness	重量(kg/m) Weight
1.3	1.041

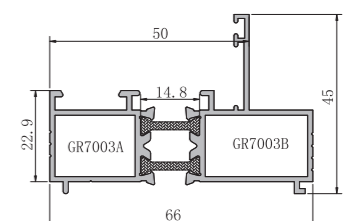

型号 Dwg NO.	GR7004
名称 Profile	中梃
壁厚(mm) Thickness	重量(kg/m) Weight
1.3	1.14

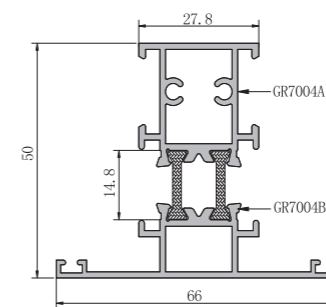

型号 Dwg NO.	GR7002
名称 Profile	推拉扇
壁厚(mm) Thickness	重量(kg/m) Weight
1.3	1.066

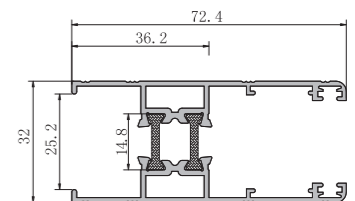

型号 Dwg NO.	GR7008
名称 Profile	收口
壁厚(mm) Thickness	重量(kg/m) Weight
1.2	0.587

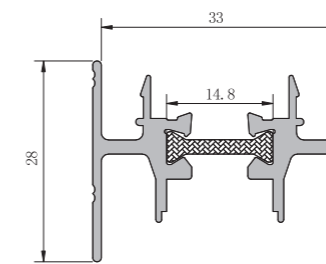

型号 Dwg NO.	GR7006A
名称 Profile	纱窗料
壁厚(mm) Thickness	重量(kg/m) Weight
1.15	0.494

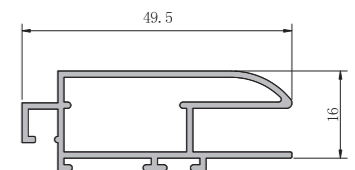

型号 Dwg NO.	GR7001B
名称 Profile	披水板
壁厚(mm) Thickness	重量(kg/m) Weight
1.1	0.255

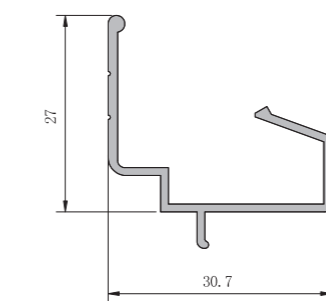

型号 Dwg NO.	GR7014A
名称 Profile	压线
壁厚(mm) Thickness	重量(kg/m) Weight
0.8	0.161

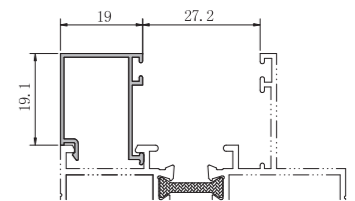

型号 Dwg NO.	GR7002B
名称 Profile	扇封边
壁厚(mm) Thickness	重量(kg/m) Weight
1.1	0.362

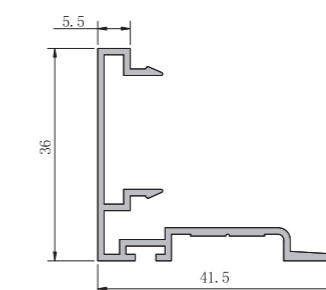

型号 Dwg NO.	
名称 Profile	
壁厚(mm) Thickness	重量(kg/m) Weight

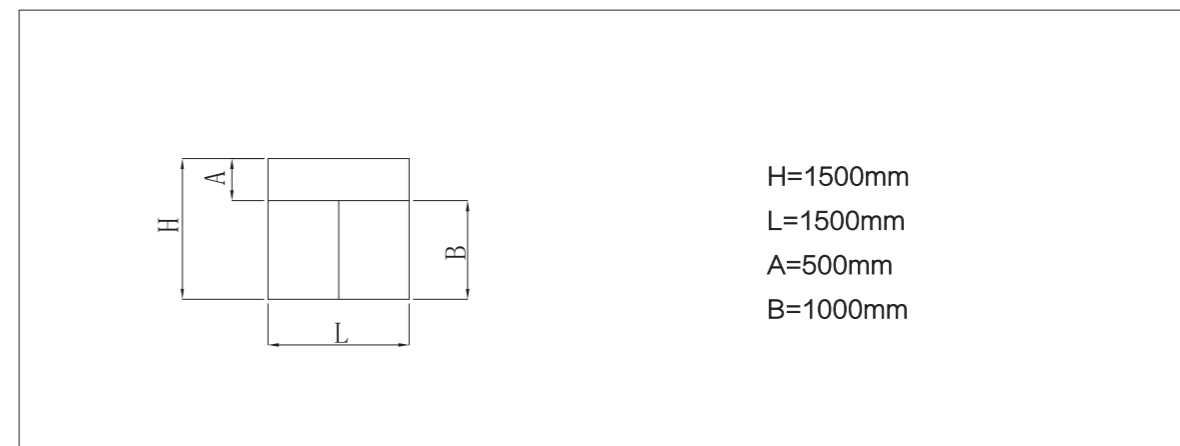
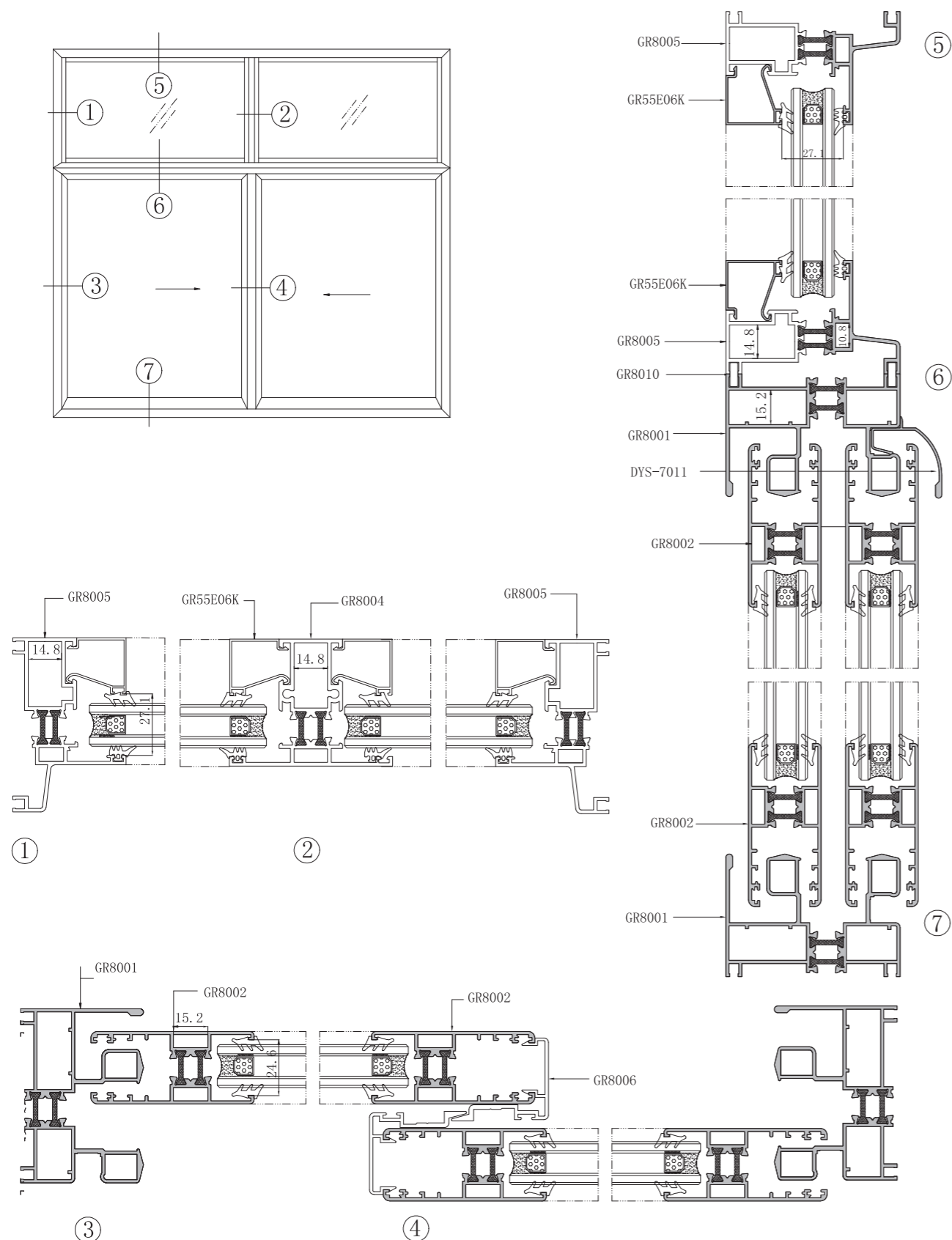

H=1500mm
L=1500mm
A=500mm
B=1000mm

用料清单 (仅供参考)

名称	型号	公式	长度 (mm)	每米重量	数量	重量(kg)
横固定窗框	GR8005	L	1500	1.267	2	3.801
竖固定窗框	GR8005	A	500	1.267	2	1.267
固定窗横压线	GR55E06K	L-100	1400	0.215	2	0.602
固定窗竖压线	GR55E06K	A-56.4	443.6	0.215	2	0.191
上滑	GR8001	L	1500	1.814	1	2.721
下滑	GR8001	L	1500	1.814	1	2.721
边封	GR8001	B	1000	1.814	2	3.628
光企	GR8002	B-85	915	1.152	2	2.108
勾企	GR8002+GR8006	B-85	915	1.631	2	2.984
上方	GR8002	L/2-63	687	1.152	2	1.583
下方	GR8002	L/2-63	687	1.152	2	1.583
合计 (kg)						23.189
铝窗面积	宽1.5米		高1.5米		2.25m ²	
单位重量	23.189/2.25=10.306g/m ²					

型号 Dwg NO.	GR8001
名称 Profile	推拉框
壁厚(mm) Thickness	重量(kg/m) Weight
1.4	1.820

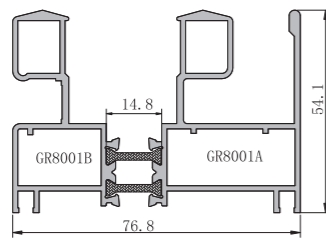

型号 Dwg NO.	GR8003ZH
名称 Profile	勾企
壁厚(mm) Thickness	重量(kg/m) Weight
1.4	1.632

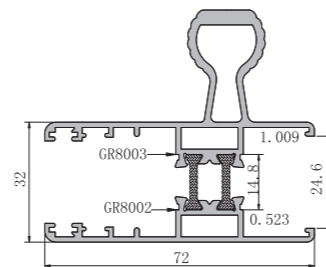

型号 Dwg NO.	GR8002ZH
名称 Profile	推拉扇
壁厚(mm) Thickness	重量(kg/m) Weight
1.4	1.147

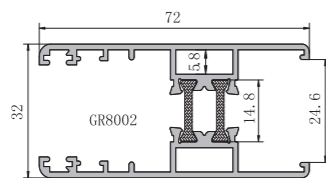

型号 Dwg NO.	GR8002A-ZH
名称 Profile	推拉扇
壁厚(mm) Thickness	重量(kg/m) Weight
1.4	1.117

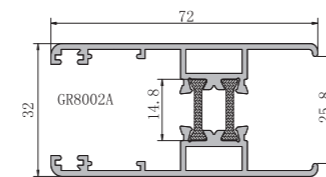

型号 Dwg NO.	GR8004
名称 Profile	中梃
壁厚(mm) Thickness	重量(kg/m) Weight
1.4	1.413

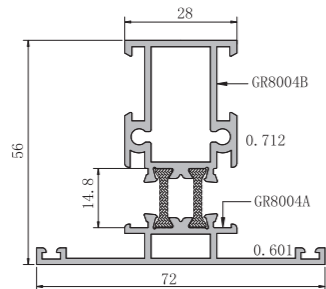

型号 Dwg NO.	GR8005
名称 Profile	固定框
壁厚(mm) Thickness	重量(kg/m) Weight
1.4	1.271

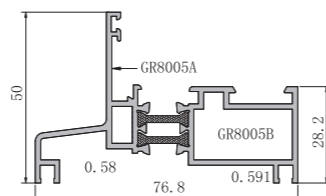

型号 Dwg NO.	GR8003ZH
名称 Profile	推拉扇
壁厚(mm) Thickness	重量(kg/m) Weight
1.4	1.096

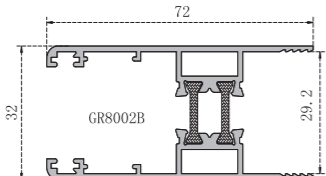

型号 Dwg NO.	GR8013ZH
名称 Profile	拼管
壁厚(mm) Thickness	重量(kg/m) Weight
1.4	1.049

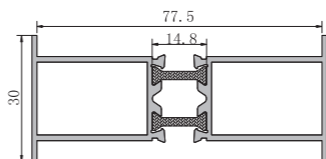

型号 Dwg NO.	GR8001ZH
名称 Profile	推拉扇
壁厚(mm) Thickness	重量(kg/m) Weight
1.4	1.742

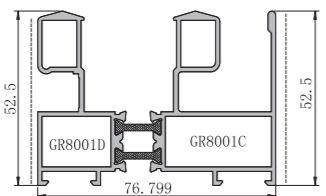

型号 Dwg NO.	GR8011ZH
名称 Profile	收口
壁厚(mm) Thickness	重量(kg/m) Weight
1.4	0.351

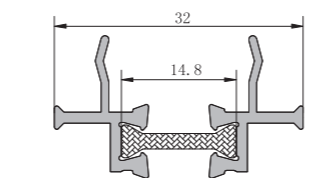

型号 Dwg NO.	GR8007
名称 Profile	纱窗料
壁厚(mm) Thickness	重量(kg/m) Weight
1.4	0.439

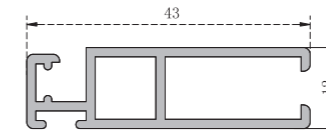

型号 Dwg NO.	GR8010
名称 Profile	连接条
壁厚(mm) Thickness	重量(kg/m) Weight
	0.1

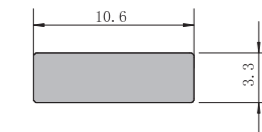

型号 Dwg NO.	GR8006
名称 Profile	扇封边
壁厚(mm) Thickness	重量(kg/m) Weight
1.5	0.483

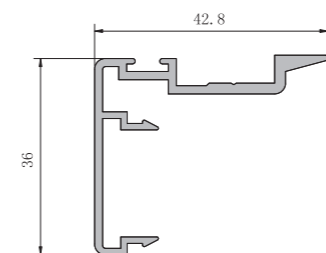

型号 Dwg NO.	DYS-7011
名称 Profile	挡水披
壁厚(mm) Thickness	重量(kg/m) Weight
1.1	0.243

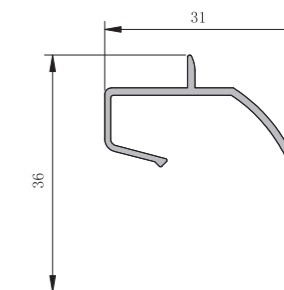

型号 Dwg NO.	
名称 Profile	
壁厚(mm) Thickness	重量(kg/m) Weight

型号 Dwg NO.	
名称 Profile	
壁厚(mm) Thickness	重量(kg/m) Weight

型号 Dwg NO.	
名称 Profile	
壁厚(mm) Thickness	重量(kg/m) Weight

型号 Dwg NO.	
名称 Profile	
壁厚(mm) Thickness	重量(kg/m) Weight

型号 Dwg NO.	
名称 Profile	
壁厚(mm) Thickness	重量(kg/m) Weight

型号 Dwg NO.	
名称 Profile	
壁厚(mm) Thickness	重量(kg/m) Weight

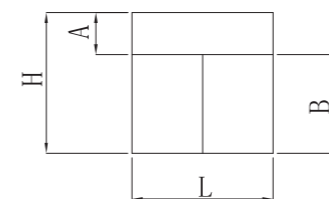
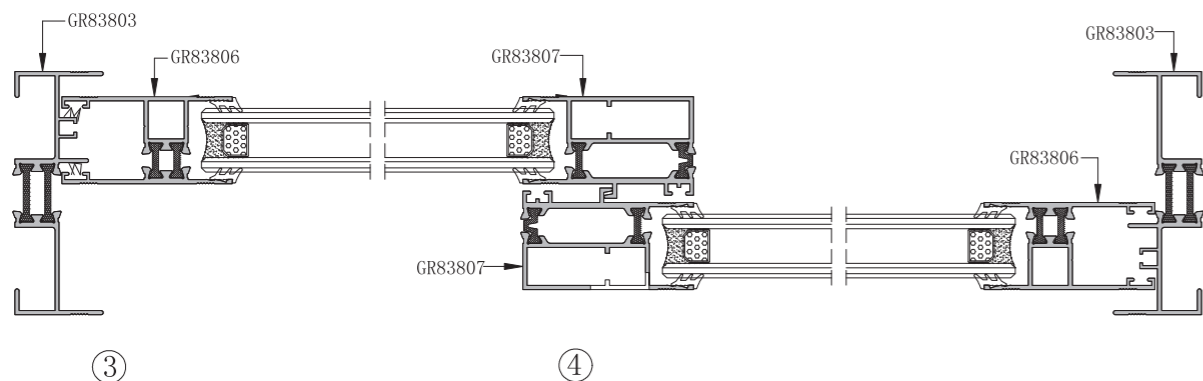
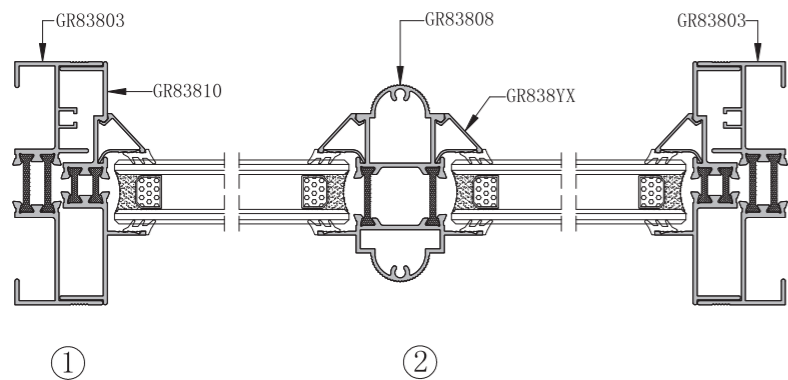
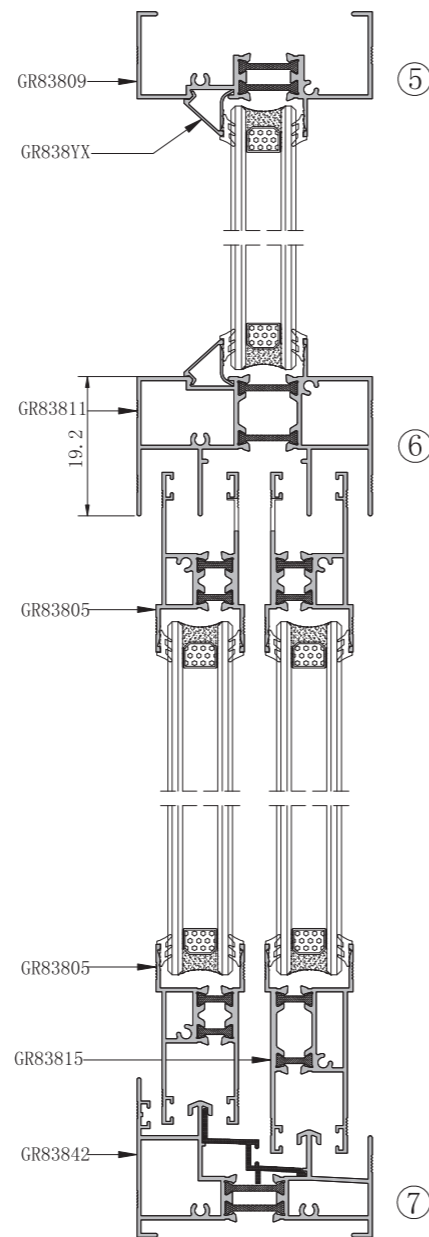
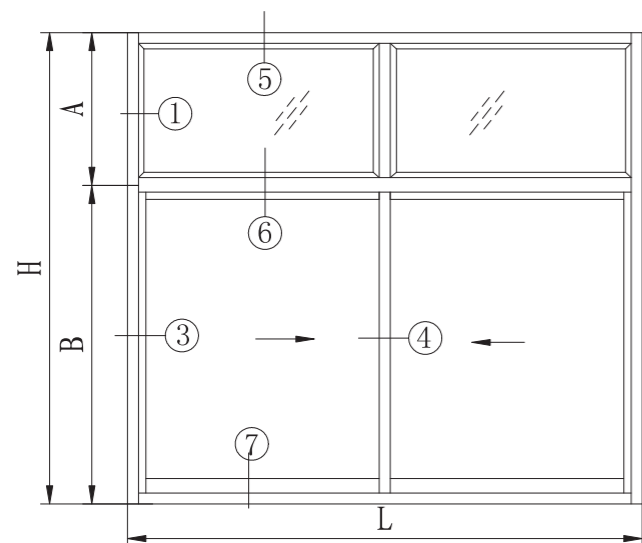

H=1500mm
L=1500mm
A=500mm
B=1000mm

用料清单 (仅供参考)

名称	型号	公式	长度 (mm)	每米重量	数量	重量(kg)
边封	GR83803	H	1500	0.976	2	2.928
上固定	GR83809	L-30	1470	1.004	1	1.476
固上滑	GR83811	L-30	1470	1.55	1	2.278
下滑	GR83842	L-30	1470	1.519	1	2.233
中柱	GR83808	A-54	446	1.159	1	0.517
插板	GR83810	A-54	446	0.792	2	0.706
固定窗竖压线	GR838YX	A-54	446	0.094	4	0.168
固定窗横压线	GR838YX	L/2-31.4-15	703.6	0.094	4	0.265
内窗光企	GR83806	B-55	945	0.859	1	0.812
内窗勾企	GR83817	B-55	945	1.228	1	1.16
外窗光企	GR83806	B-45	955	0.859	1	0.82
外窗勾企	GR83807	B-45	955	1.071	1	1.023
内窗上方	GR83805	L/2-72	678	0.954	1	0.647
内窗下方	GR83805	L/2-72	678	0.954	1	0.647
外窗上方	GR83805	L/2-72	678	0.954	1	0.647
外窗下方	GR83815	L/2-72	678	1.079	1	0.731
合计 (kg)						17.058
铝窗面积	宽1.5米		高1.5米		2.25m ²	
单位重量	17.058/2.25=7.581kg/m ²					

型号 Dwg NO.	GR83801ZH
名称 Profile	平上滑
壁厚(mm) Thickness	重量(kg/m) Weight
1.4	1.176

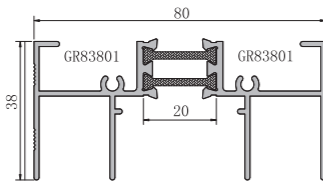

型号 Dwg NO.	GR83811
名称 Profile	固上滑
壁厚(mm) Thickness	重量(kg/m) Weight
1.4	1.55

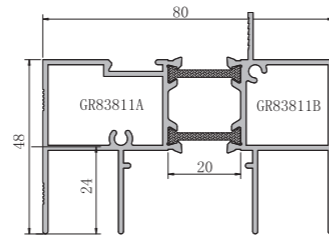

型号 Dwg NO.	GR83842
名称 Profile	平下滑
壁厚(mm) Thickness	重量(kg/m) Weight
1.4	1.519

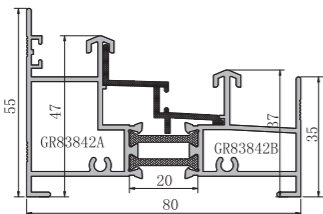

型号 Dwg NO.	GR83862
名称 Profile	平下滑
壁厚(mm) Thickness	重量(kg/m) Weight
1.4	1.308

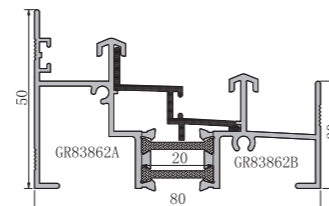

型号 Dwg NO.	GR83802
名称 Profile	平下滑
壁厚(mm) Thickness	重量(kg/m) Weight
1.4	1.291

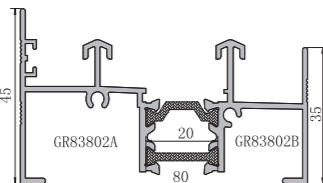

型号 Dwg NO.	GR83812
名称 Profile	固下滑
壁厚(mm) Thickness	重量(kg/m) Weight
1.4	1.529

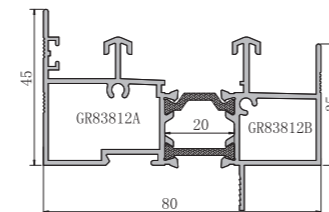

型号 Dwg NO.	GR83852
名称 Profile	连体固下滑
壁厚(mm) Thickness	重量(kg/m) Weight
1.4	1.602

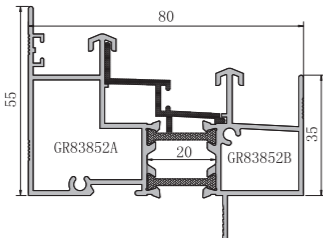

型号 Dwg NO.	GR838M02ZH
名称 Profile	门下滑
壁厚(mm) Thickness	重量(kg/m) Weight
1.4	0.971

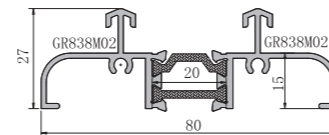

型号 Dwg NO.	GR83822
名称 Profile	平下滑
壁厚(mm) Thickness	重量(kg/m) Weight
1.4	1.333

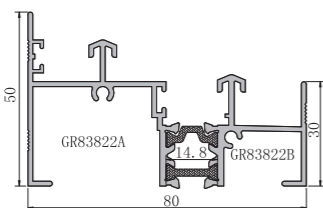

型号 Dwg NO.	GR83832
名称 Profile	连体固下滑
壁厚(mm) Thickness	重量(kg/m) Weight
1.4	1.568

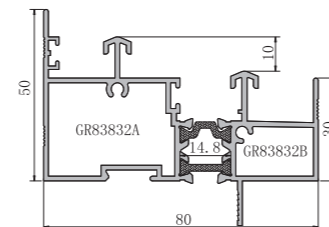

型号 Dwg NO.	GR83803
名称 Profile	边封
壁厚(mm) Thickness	重量(kg/m) Weight
1.4	0.976

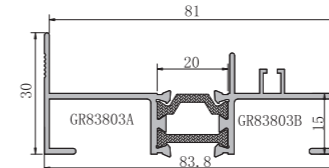

型号 Dwg NO.	GR83843
名称 Profile	管边封
壁厚(mm) Thickness	重量(kg/m) Weight
1.4	1.227

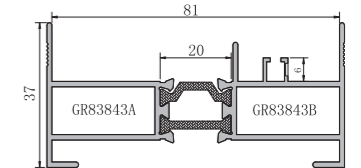

型号 Dwg NO.	GR83813ZH
名称 Profile	双边封
壁厚(mm) Thickness	重量(kg/m) Weight
1.4	1.378

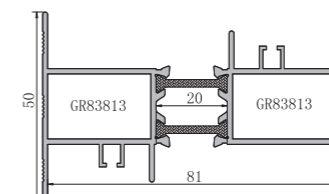

型号 Dwg NO.	GR83823
名称 Profile	双边封
壁厚(mm) Thickness	重量(kg/m) Weight
1.4	1.393

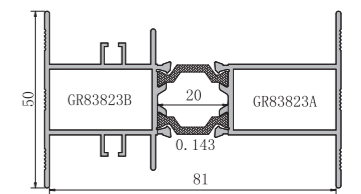

型号 Dwg NO.	GR83853
名称 Profile	单边封
壁厚(mm) Thickness	重量(kg/m) Weight
1.4	1.014

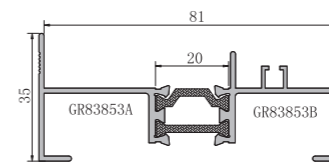

型号 Dwg NO.	GR83844
名称 Profile	下方
壁厚(mm) Thickness	重量(kg/m) Weight
1.4	0.933

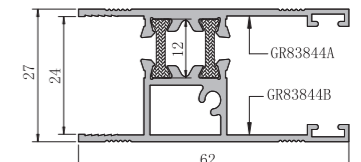

型号 Dwg NO.	GR83805
名称 Profile	上下方
壁厚(mm) Thickness	重量(kg/m) Weight
1.4	0.954

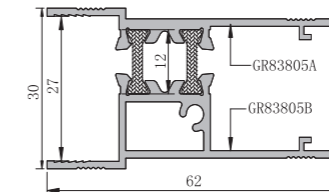

型号 Dwg NO.	GR83815
名称 Profile	大下方
壁厚(mm) Thickness	重量(kg/m) Weight
1.4	1.079

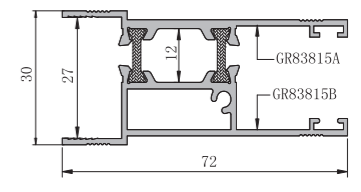

型号 Dwg NO.	GR83845ZH
名称 Profile	大下方
壁厚(mm) Thickness	重量(kg/m) Weight
1.4	1.064

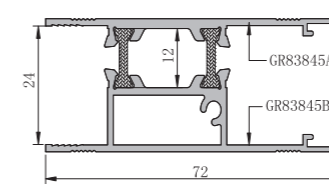

型号 Dwg NO.	GR83846
名称 Profile	光企
壁厚(mm) Thickness	重量(kg/m) Weight
1.4	0.766

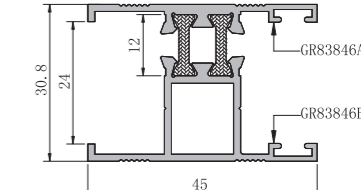

型号 Dwg NO.	GR83826
名称 Profile	光企
壁厚(mm) Thickness	重量(kg/m) Weight
1.4	0.743

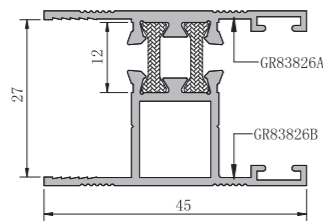

型号 Dwg NO.	GR83806
名称 Profile	光企
壁厚(mm) Thickness	重量(kg/m) Weight
1.4	0.859

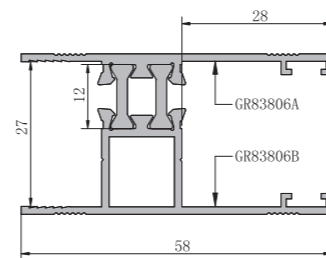

型号 Dwg NO.	GR83836
名称 Profile	光企
壁厚(mm) Thickness	重量(kg/m) Weight
1.4	1.034

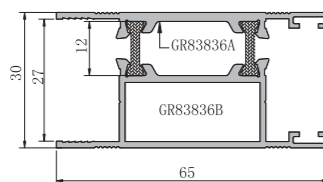

型号 Dwg NO.	GR83847
名称 Profile	勾企
壁厚(mm) Thickness	重量(kg/m) Weight
1.4	0.921

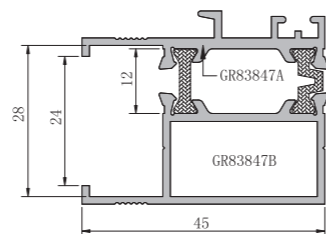

型号 Dwg NO.	GR83837
名称 Profile	勾企
壁厚(mm) Thickness	重量(kg/m) Weight
1.4	1.132

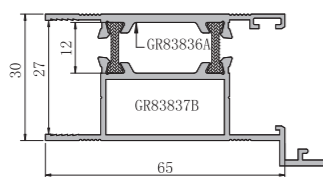

型号 Dwg NO.	GR83807
名称 Profile	勾企
壁厚(mm) Thickness	重量(kg/m) Weight
1.4	1.071

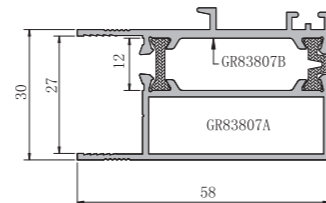

型号 Dwg NO.	GR83857
名称 Profile	大勾企
壁厚(mm) Thickness	重量(kg/m) Weight
1.4	1.055

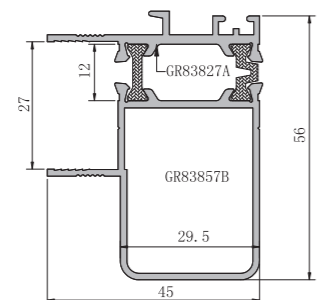

型号 Dwg NO.	GR83817
名称 Profile	大勾企
壁厚(mm) Thickness	重量(kg/m) Weight
1.4	1.228

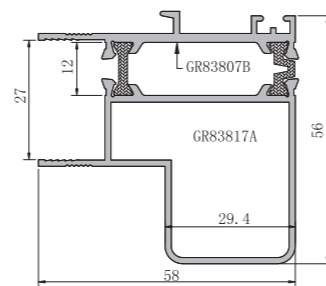

型号 Dwg NO.	GR83827
名称 Profile	勾企
壁厚(mm) Thickness	重量(kg/m) Weight
1.4	0.898

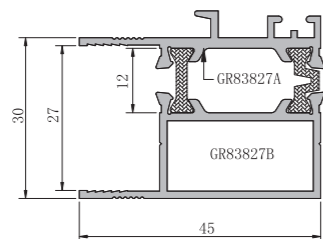

型号 Dwg NO.	GR83838
名称 Profile	中柱
壁厚(mm) Thickness	重量(kg/m) Weight
1.4	1.267

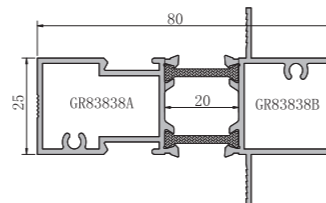

型号 Dwg NO.	GR83808
名称 Profile	中柱
壁厚(mm) Thickness	重量(kg/m) Weight
1.4	1.159

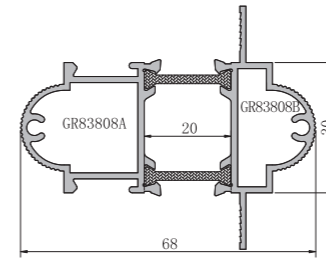

型号 Dwg NO.	GR83809
名称 Profile	上固定
壁厚(mm) Thickness	重量(kg/m) Weight
1.4	1.004

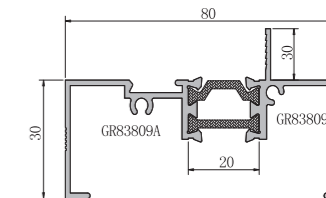

型号 Dwg NO.	GR83810
名称 Profile	插板
壁厚(mm) Thickness	重量(kg/m) Weight
1.4	0.792

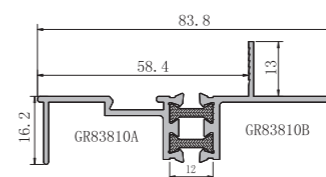

型号 Dwg NO.	GR83818ZH
名称 Profile	拼管
壁厚(mm) Thickness	重量(kg/m) Weight
1.4	1.024

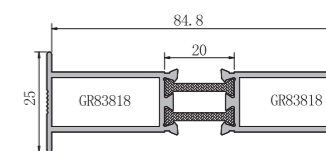

型号 Dwg NO.	GR838KG-ZH
名称 Profile	收口
壁厚(mm) Thickness	重量(kg/m) Weight
1.4	0.433

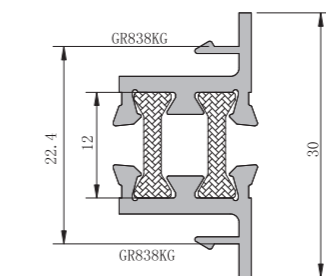

型号 Dwg NO.	GR83828ZH
名称 Profile	收口
壁厚(mm) Thickness	重量(kg/m) Weight
1.2	0.567

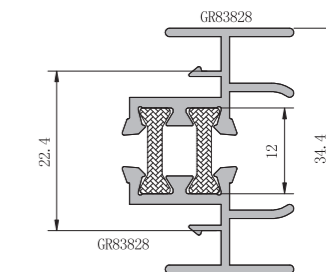

型号 Dwg NO.	GR83817ZH
名称 Profile	大勾企
壁厚(mm) Thickness	重量(kg/m) Weight
1.4	1.239

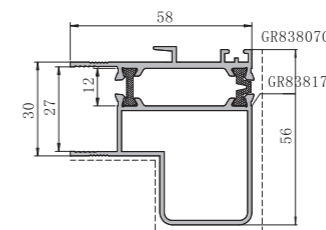

型号 Dwg NO.	GR838SC
名称 Profile	纱窗料
壁厚(mm) Thickness	重量(kg/m) Weight
0.8	0.265

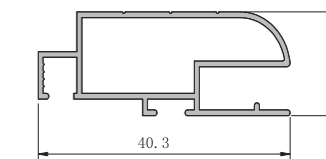

型号 Dwg NO.	GR83821
名称 Profile	中滑
壁厚(mm) Thickness	重量(kg/m) Weight
1.4	1.841

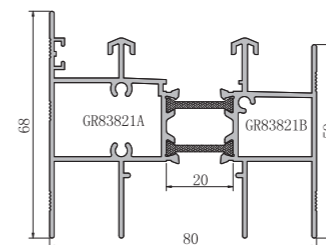

型号 Dwg NO.	GR83845
名称 Profile	135° 转角
壁厚(mm) Thickness	重量(kg/m) Weight
1.4	0.671

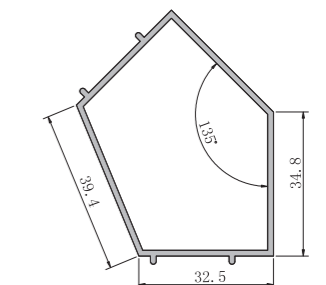

型号 Dwg NO.	GR83890
名称 Profile	90° 转角
壁厚(mm) Thickness	重量(kg/m) Weight
1.4	1.033

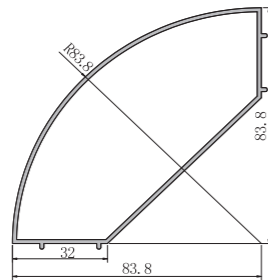

型号 Dwg NO.	GR83890-1
名称 Profile	90° 转角
壁厚(mm) Thickness	重量(kg/m) Weight
1.4	1.855

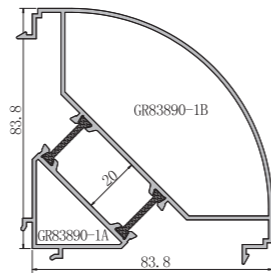

型号 Dwg NO.	GR83890-2
名称 Profile	90° 转角
壁厚(mm) Thickness	重量(kg/m) Weight
1.5	1.448

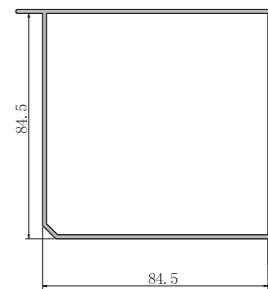

型号 Dwg NO.	GR838GD-1
名称 Profile	左固定边封
壁厚(mm) Thickness	重量(kg/m) Weight
1.4	1.34

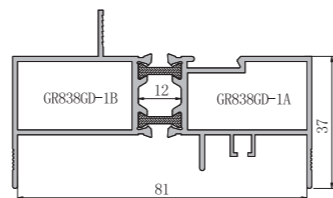

型号 Dwg NO.	GR838GD-2
名称 Profile	右固定边封
壁厚(mm) Thickness	重量(kg/m) Weight
1.4	1.34

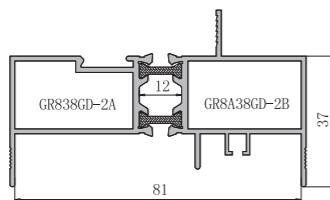

型号 Dwg NO.	LTGR83843
名称 Profile	边封
壁厚(mm) Thickness	重量(kg/m) Weight
1.4	1.22

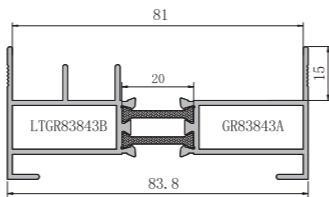

型号 Dwg NO.	LTGR83807ZH
名称 Profile	勾企
壁厚(mm) Thickness	重量(kg/m) Weight
1.4	1.086

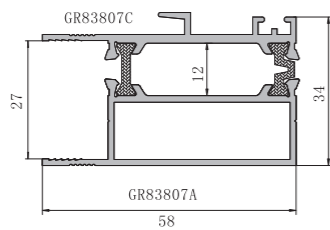

型号 Dwg NO.	GR838S9
名称 Profile	单玻槽
壁厚(mm) Thickness	重量(kg/m) Weight
0.8	0.131

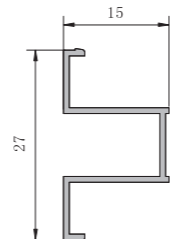

型号 Dwg NO.	LTGR83806ZH
名称 Profile	光企
壁厚(mm) Thickness	重量(kg/m) Weight
1.4	1.182

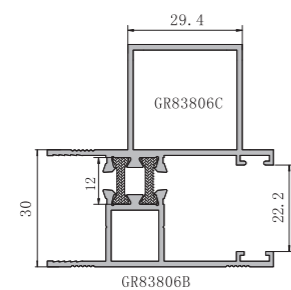

型号 Dwg NO.	GR838YX24
名称 Profile	压线
壁厚(mm) Thickness	重量(kg/m) Weight
0.8	0.118

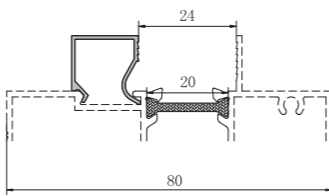

型号 Dwg NO.	GR838YX
名称 Profile	压线
壁厚(mm) Thickness	重量(kg/m) Weight
0.8	0.094

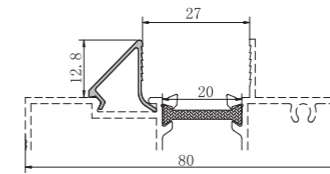

型号 Dwg NO.	GR838XA
名称 Profile	压线
壁厚(mm) Thickness	重量(kg/m) Weight
0.8	0.11

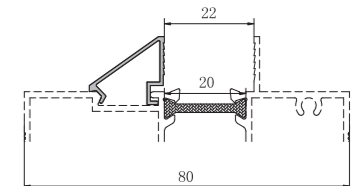

型号 Dwg NO.	
名称 Profile	
壁厚(mm) Thickness	重量(kg/m) Weight

型号 Dwg NO.	
名称 Profile	
壁厚(mm) Thickness	重量(kg/m) Weight

型号 Dwg NO.	
名称 Profile	
壁厚(mm) Thickness	重量(kg/m) Weight

型号 Dwg NO.	
名称 Profile	
壁厚(mm) Thickness	重量(kg/m) Weight

型号 Dwg NO.	
名称 Profile	
壁厚(mm) Thickness	重量(kg/m) Weight

型号 Dwg NO.	
名称 Profile	
壁厚(mm) Thickness	重量(kg/m) Weight

型号 Dwg NO.	
名称 Profile	
壁厚(mm) Thickness	重量(kg/m) Weight

型号 Dwg NO.	
名称 Profile	
壁厚(mm) Thickness	重量(kg/m) Weight

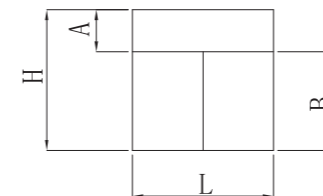
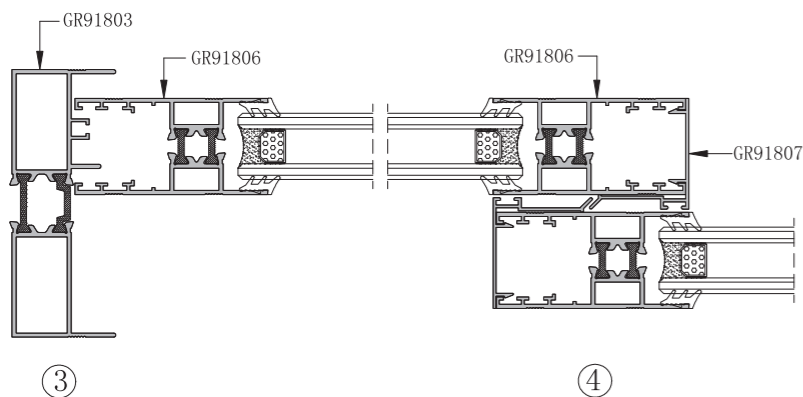
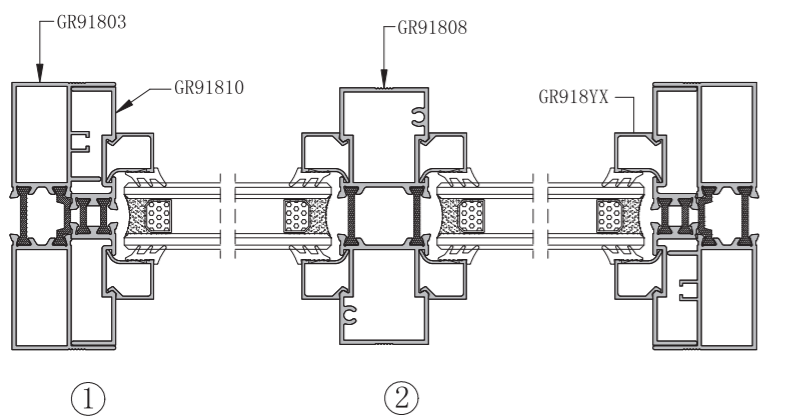
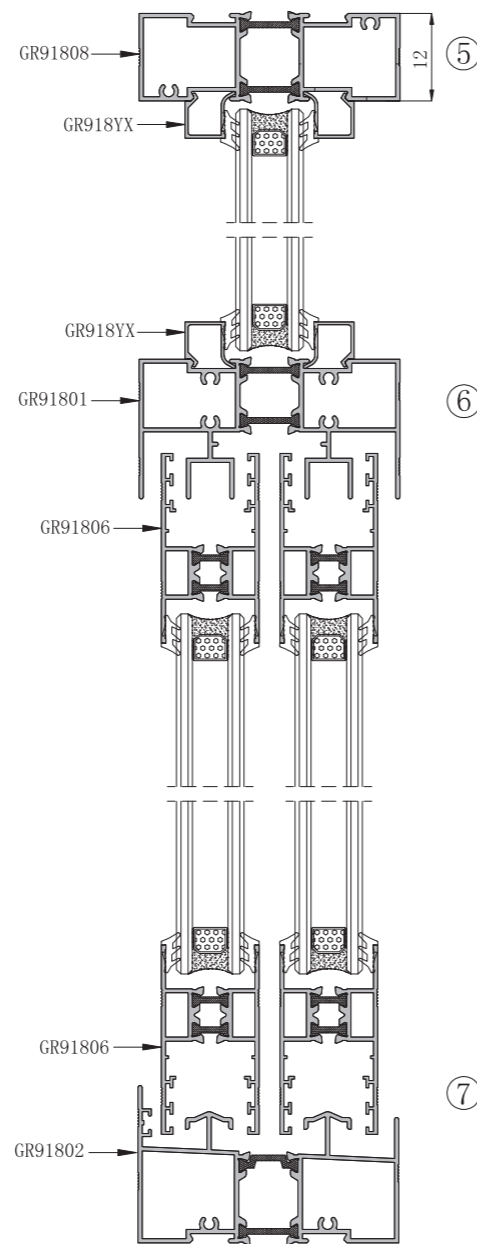
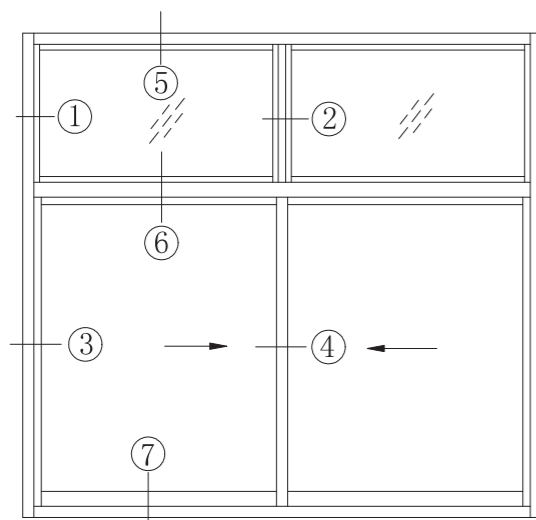

H=1500mm
L=1500mm
A=500mm
B=1000mm

用料清单 (仅供参考)

名称	型号	公式	长度 (mm)	每米重量	数量	重量(kg)	
边封	GR91803	H	1500	1.272	2	3.816	
上固定	GR91808	L-40	1460	1.361	1	1.987	
固上滑	GR91801	L-40	1460	1.868	1	2.727	
下滑	GR91802	L-40	1460	1.770	1	2.584	
插板	GR91810	A-54	446	0.803	2	0.716	
固定窗竖压线	GR918YX	A-79.6	420	0.135	4	0.227	
固定窗横压线	GR918YX	L-70	1300	0.135	4	0.702	
内窗光企	GR91806	B-53	947	1.068	1	1.011	
内窗勾企	GR91806\GR91807	B-53	947	1.316	1	1.246	
外窗光企	GR91806	B-53	947	1.068	1	1.011	
外窗勾企	GR91806\GR91807	B-53	947	1.316	1	1.246	
内窗上方	GR91805	L/2-88	662	0.911	1	0.603	
内窗下方	GR91805	L/2-88	662	0.911	1	0.603	
外窗上方	GR91805	L/2-88	662	0.911	1	0.60	
外窗下方	GR91805	L/2-88	662	0.911	1	0.60	
合计 (kg)							19.69
铝窗面积	宽1.5米		高1.5米			2.25m ²	
单位重量							19.69/2.25=8.751kg/m ²

型号 Dwg NO.	GR91801ZH	
名称 Profile	上滑	
壁厚(mm) Thickness	重量(kg/m) Weight	
1.4	1.868	

型号 Dwg NO.	GR91806ZH	
名称 Profile	光企	
壁厚(mm) Thickness	重量(kg/m) Weight	
1.4	1.068	

型号 Dwg NO.	GR91802	
名称 Profile	下滑	
壁厚(mm) Thickness	重量(kg/m) Weight	
1.4	1.77	

型号 Dwg NO.	GR91807	
名称 Profile	勾企盖板	
壁厚(mm) Thickness	重量(kg/m) Weight	
1.0	0.248	

型号 Dwg NO.	GR91803	
名称 Profile	边封	
壁厚(mm) Thickness	重量(kg/m) Weight	
1.4	1.272	

型号 Dwg NO.	GR918YX	
名称 Profile	压线	
壁厚(mm) Thickness	重量(kg/m) Weight	
1.0	0.135	

型号 Dwg NO.	GR91808ZH	
名称 Profile	中柱	
壁厚(mm) Thickness	重量(kg/m) Weight	
1.4	1.361	

型号 Dwg NO.	GR91805	
名称 Profile	下方	
壁厚(mm) Thickness	重量(kg/m) Weight	
1.4	0.911	

型号 Dwg NO.	GR91810ZH	
名称 Profile	插板	
壁厚(mm) Thickness	重量(kg/m) Weight	
1.4	0.803	

型号 Dwg NO.	GR91816	
名称 Profile	光企	
壁厚(mm) Thickness	重量(kg/m) Weight	
1.4	0.875	

型号 Dwg NO.	GR91813ZH	
名称 Profile	双边封	
壁厚(mm) Thickness	重量(kg/m) Weight	
1.4	1.456	

型号 Dwg NO.	GR91827	
名称 Profile	勾企盖板	
壁厚(mm) Thickness	重量(kg/m) Weight	
1.0	0.238	

型号 Dwg NO.	GR91817	
名称 Profile	勾企盖板	
壁厚(mm) Thickness	重量(kg/m) Weight	
1.0	0.123	

型号 Dwg NO.	GR91818ZH	
名称 Profile	收口	
壁厚(mm) Thickness	重量(kg/m) Weight	
1.4	0.501	

型号 Dwg NO.	GR91802	
名称 Profile	下滑	
壁厚(mm) Thickness	重量(kg/m) Weight	
1.4	1.0673	

型号 Dwg NO.	GR91828ZH	
名称 Profile	拼管	
壁厚(mm) Thickness	重量(kg/m) Weight	
1.4	1.095	

型号 Dwg NO.		
名称 Profile		
壁厚(mm) Thickness	重量(kg/m) Weight	

型号 Dwg NO.		
名称 Profile		
壁厚(mm) Thickness	重量(kg/m) Weight	

型号 Dwg NO.		
名称 Profile		
壁厚(mm) Thickness	重量(kg/m) Weight	

型号 Dwg NO.		
名称 Profile		
壁厚(mm) Thickness	重量(kg/m) Weight	

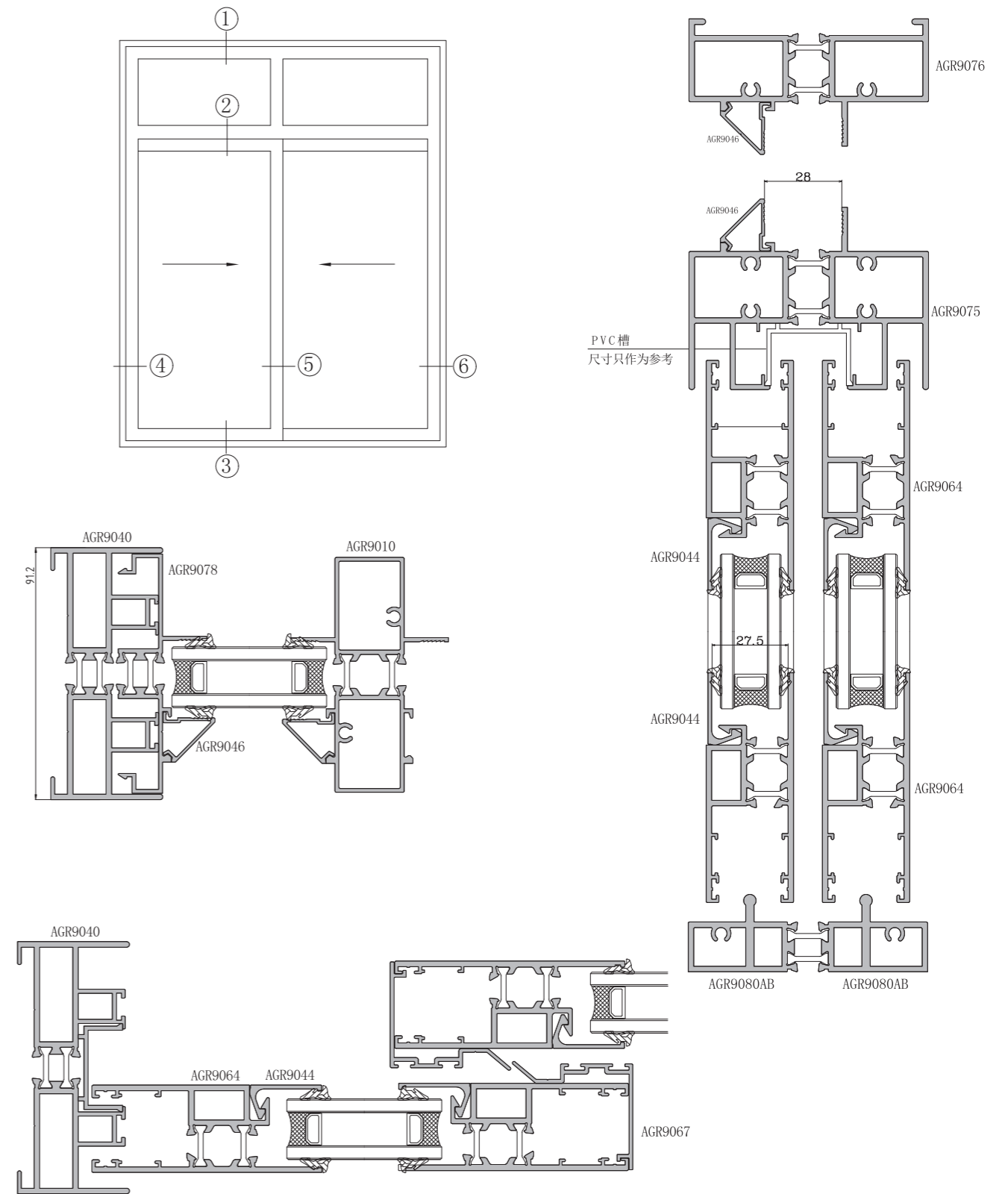
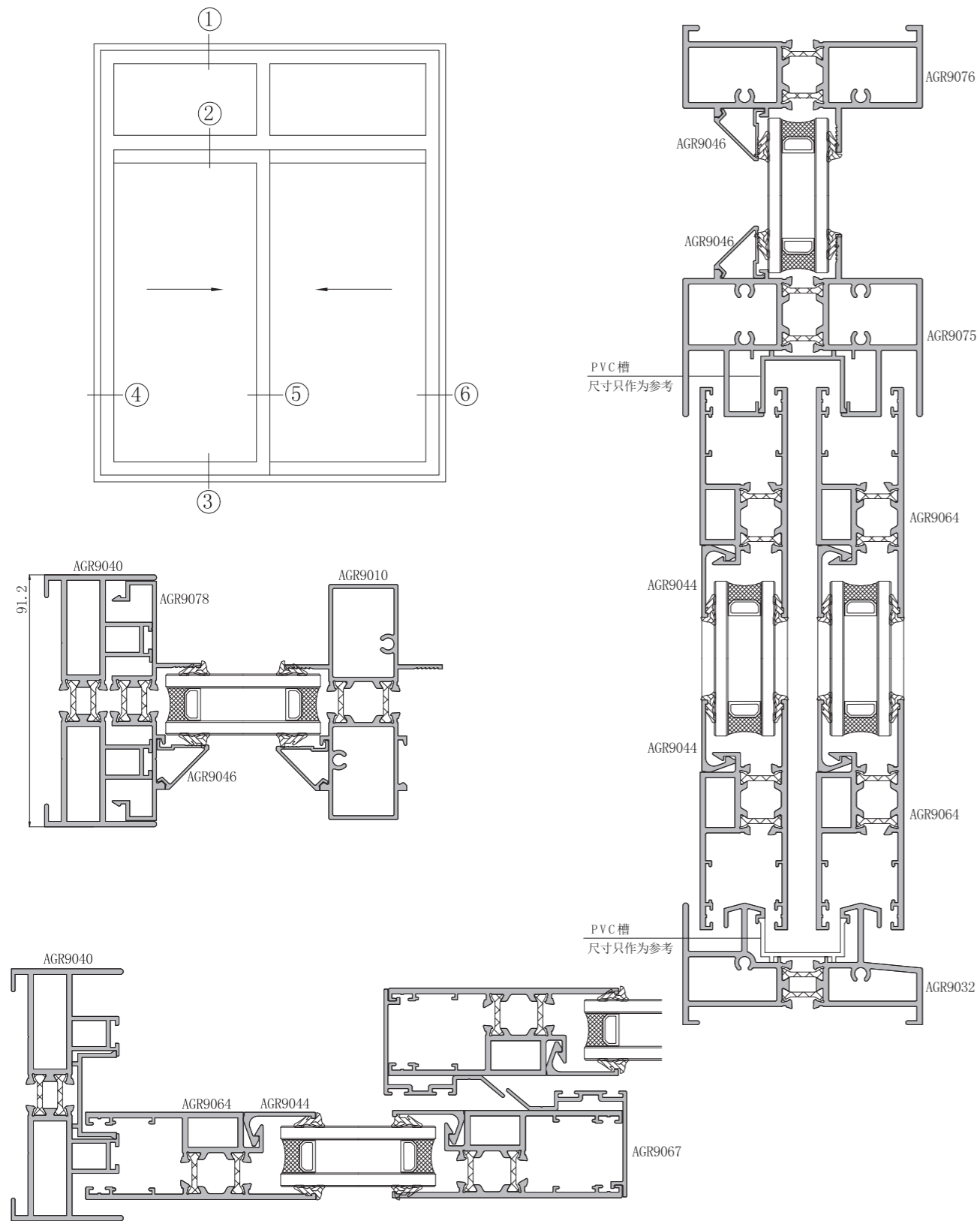

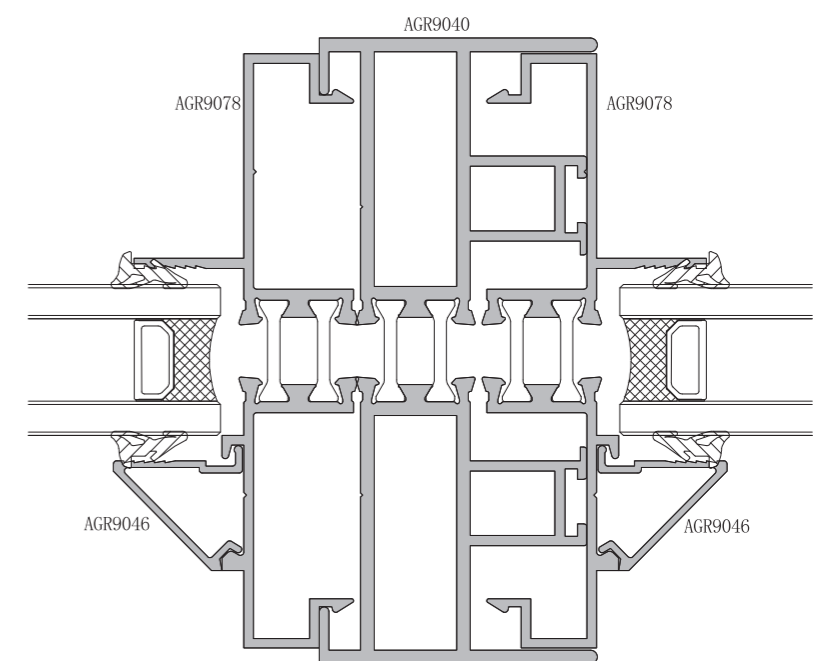
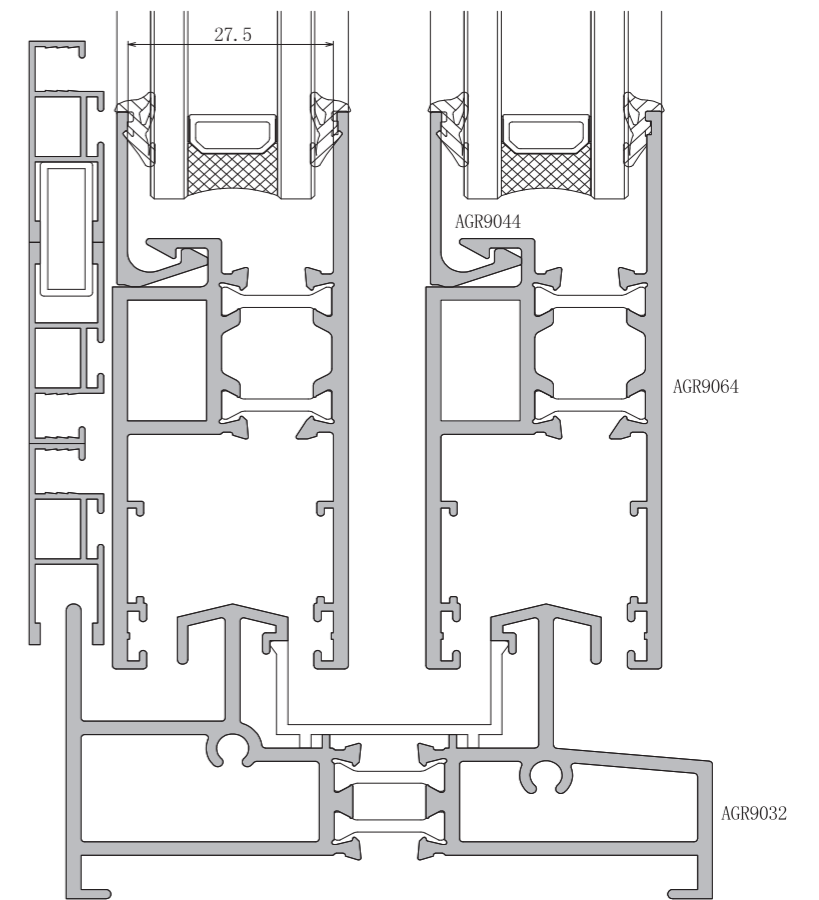
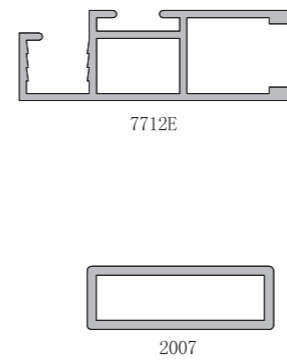
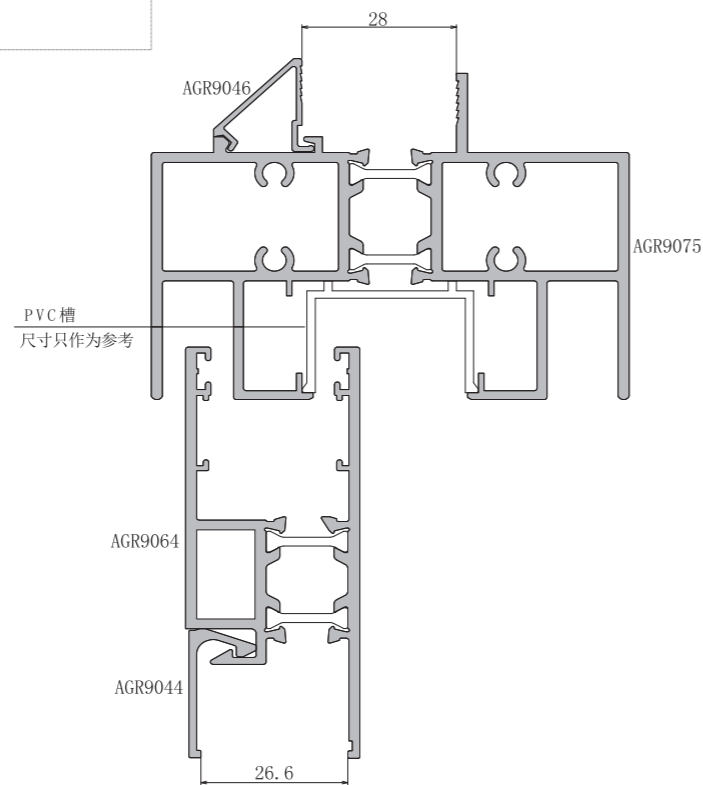
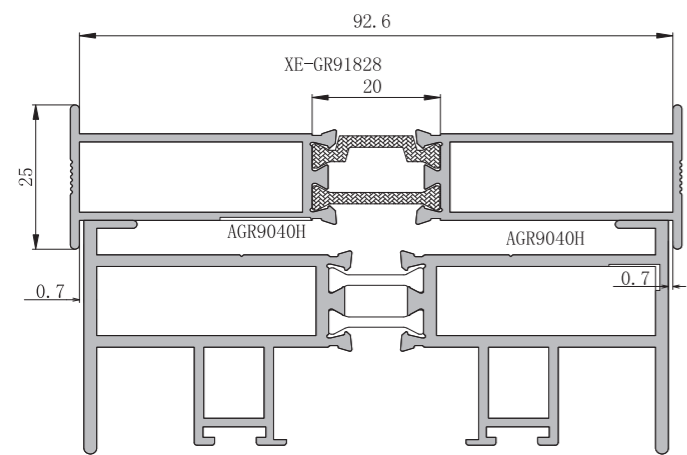
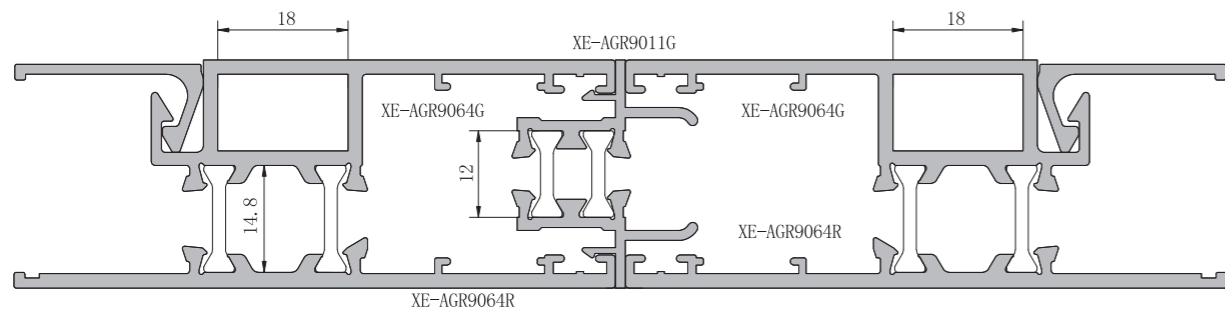

型号 Dwg NO.	AGR9075
名称 Profile	上滑
壁厚(mm) Thickness	重量(kg/m) Weight
2.0	2.438

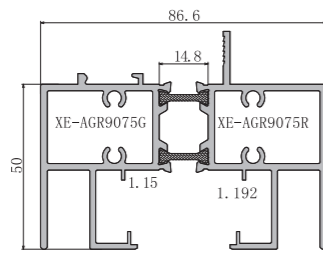

型号 Dwg NO.	AGR9010
名称 Profile	中柱
壁厚(mm) Thickness	重量(kg/m) Weight
1.4	1.421

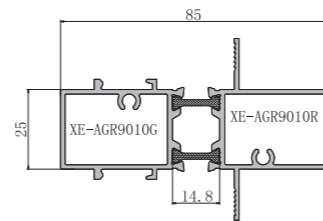

型号 Dwg NO.	AGR9032
名称 Profile	下滑
壁厚(mm) Thickness	重量(kg/m) Weight
2.0	1.971

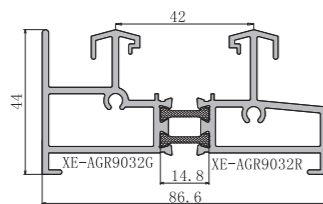

型号 Dwg NO.	AGR9078
名称 Profile	插板
壁厚(mm) Thickness	重量(kg/m) Weight
1.4	0.88

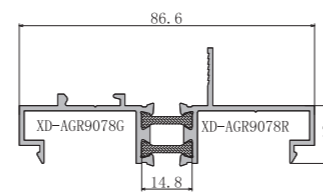

型号 Dwg NO.	AGR9076
名称 Profile	上固定
壁厚(mm) Thickness	重量(kg/m) Weight
2.0	1.769

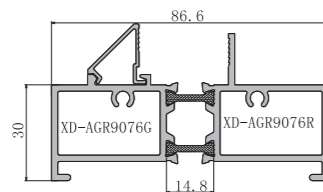

型号 Dwg NO.	AGR9064
名称 Profile	扇料
壁厚(mm) Thickness	重量(kg/m) Weight
2.0	1.401

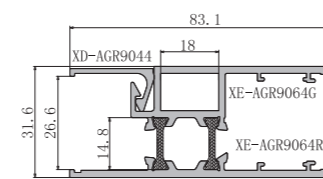

型号 Dwg NO.	AGR9066
名称 Profile	扇料
壁厚(mm) Thickness	重量(kg/m) Weight
2.0	1.903

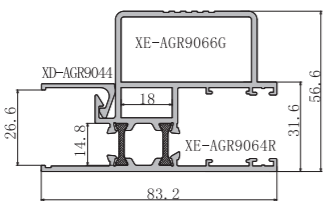

型号 Dwg NO.	AGR9067
名称 Profile	勾企盖板
壁厚(mm) Thickness	重量(kg/m) Weight
1.4	0.38

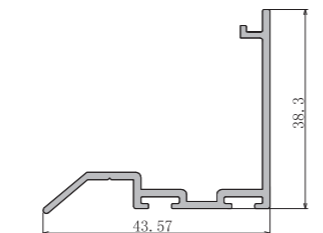

型号 Dwg NO.	AGR9046
名称 Profile	压线
壁厚(mm) Thickness	重量(kg/m) Weight
1.0	0.133

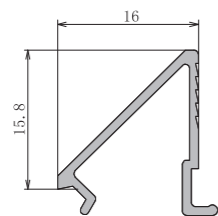

型号 Dwg NO.	AGR9044
名称 Profile	压线
壁厚(mm) Thickness	重量(kg/m) Weight
1.0	0.166

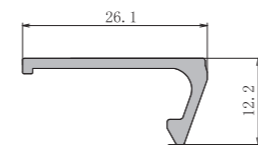

型号 Dwg NO.	AGR9033
名称 Profile	上滑
壁厚(mm) Thickness	重量(kg/m) Weight
2.0	2.094

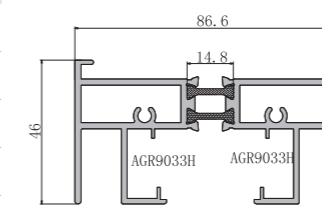

型号 Dwg NO.	AGR9040
名称 Profile	边封
壁厚(mm) Thickness	重量(kg/m) Weight
2.0	2.094

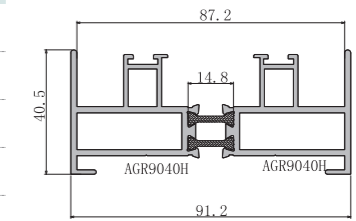

型号 Dwg NO.	AGR9011G
名称 Profile	收口
壁厚(mm) Thickness	重量(kg/m) Weight
1.4	0.208

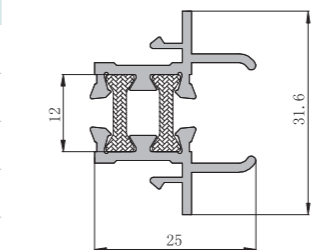

型号 Dwg NO.	
名称 Profile	
壁厚(mm) Thickness	重量(kg/m) Weight

型号 Dwg NO.	
名称 Profile	
壁厚(mm) Thickness	重量(kg/m) Weight

型号 Dwg NO.	
名称 Profile	
壁厚(mm) Thickness	重量(kg/m) Weight

型号 Dwg NO.	
名称 Profile	
壁厚(mm) Thickness	重量(kg/m) Weight

型号 Dwg NO.	
名称 Profile	
壁厚(mm) Thickness	重量(kg/m) Weight

型号 Dwg NO.	
名称 Profile	
壁厚(mm) Thickness	重量(kg/m) Weight

型号 Dwg NO.	
名称 Profile	
壁厚(mm) Thickness	重量(kg/m) Weight

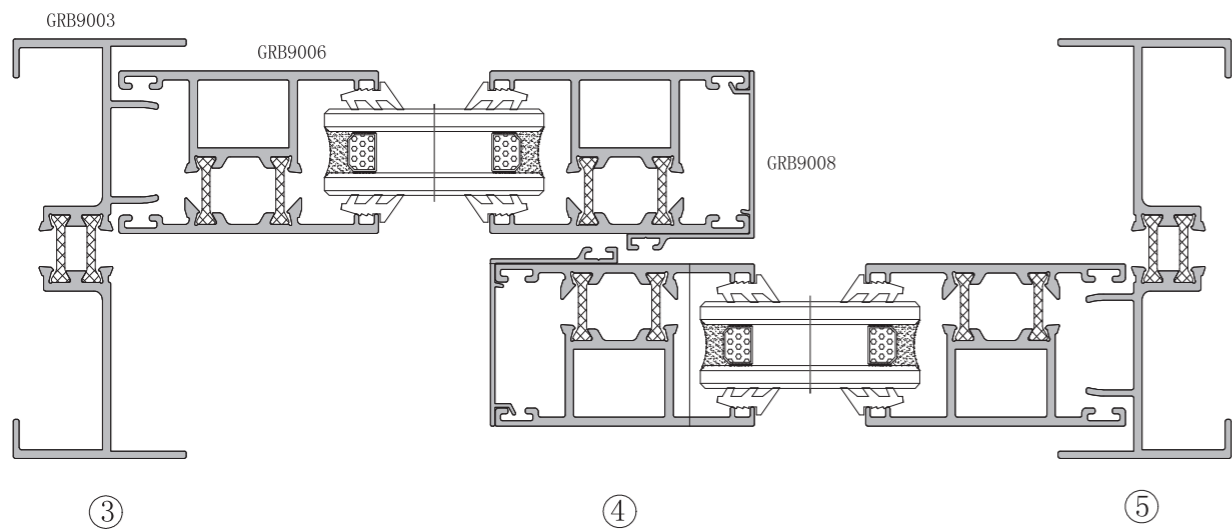
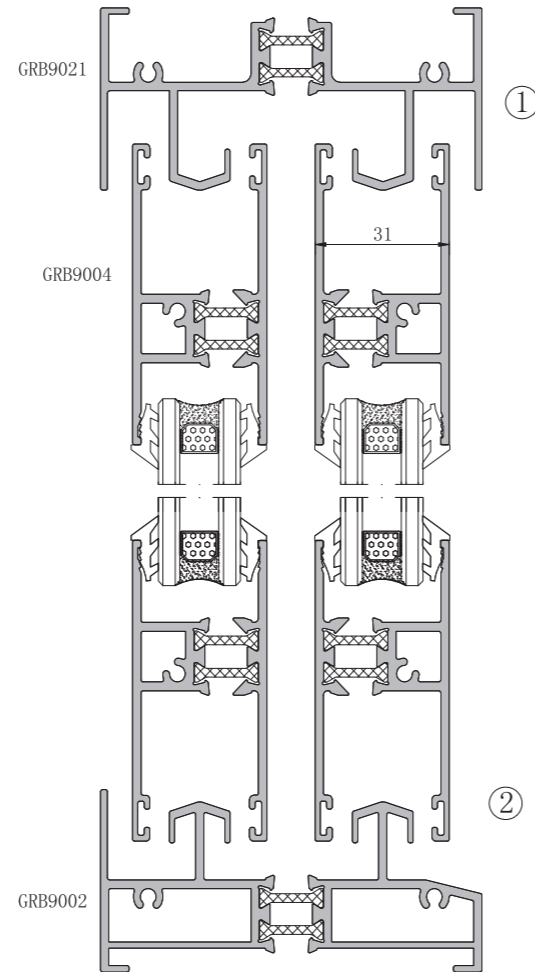
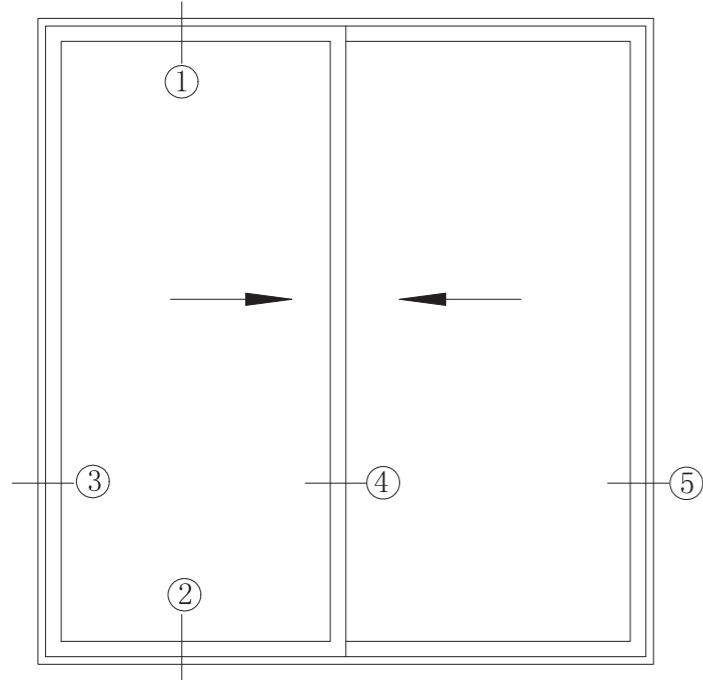

型号 Dwg NO.	GRB9021
名称 Profile	上滑
壁厚(mm) Thickness	重量(kg/m) Weight
1.9	1.588

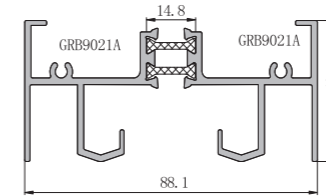

型号 Dwg NO.	GRB9004
名称 Profile	上下方
壁厚(mm) Thickness	重量(kg/m) Weight
1.95	1.177

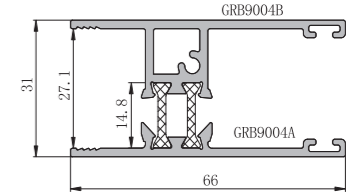

型号 Dwg NO.	GRB9002
名称 Profile	下滑
壁厚(mm) Thickness	重量(kg/m) Weight
1.9	1.733

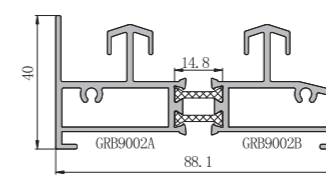

型号 Dwg NO.	GRB9006
名称 Profile	勾光企
壁厚(mm) Thickness	重量(kg/m) Weight
1.95	1.241

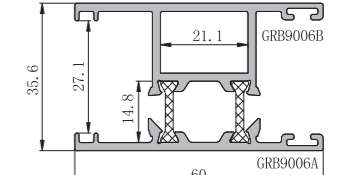

型号 Dwg NO.	GRB9003
名称 Profile	边封
壁厚(mm) Thickness	重量(kg/m) Weight
1.9	1.266

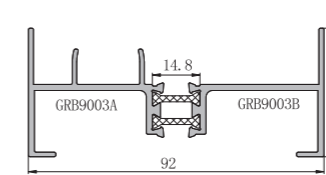

型号 Dwg NO.	GRB9018ZH
名称 Profile	收口
壁厚(mm) Thickness	重量(kg/m) Weight
1.4	0.552

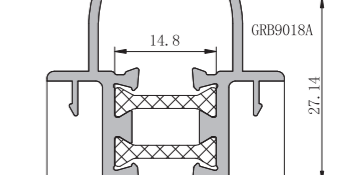

型号 Dwg NO.	GRB9008
名称 Profile	扇勾
壁厚(mm) Thickness	重量(kg/m) Weight
1.0	0.216

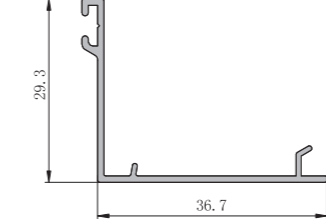

型号 Dwg NO.	
名称 Profile	
壁厚(mm) Thickness	重量(kg/m) Weight

型号 Dwg NO.	
名称 Profile	
壁厚(mm) Thickness	重量(kg/m) Weight

型号 Dwg NO.	
名称 Profile	
壁厚(mm) Thickness	重量(kg/m) Weight

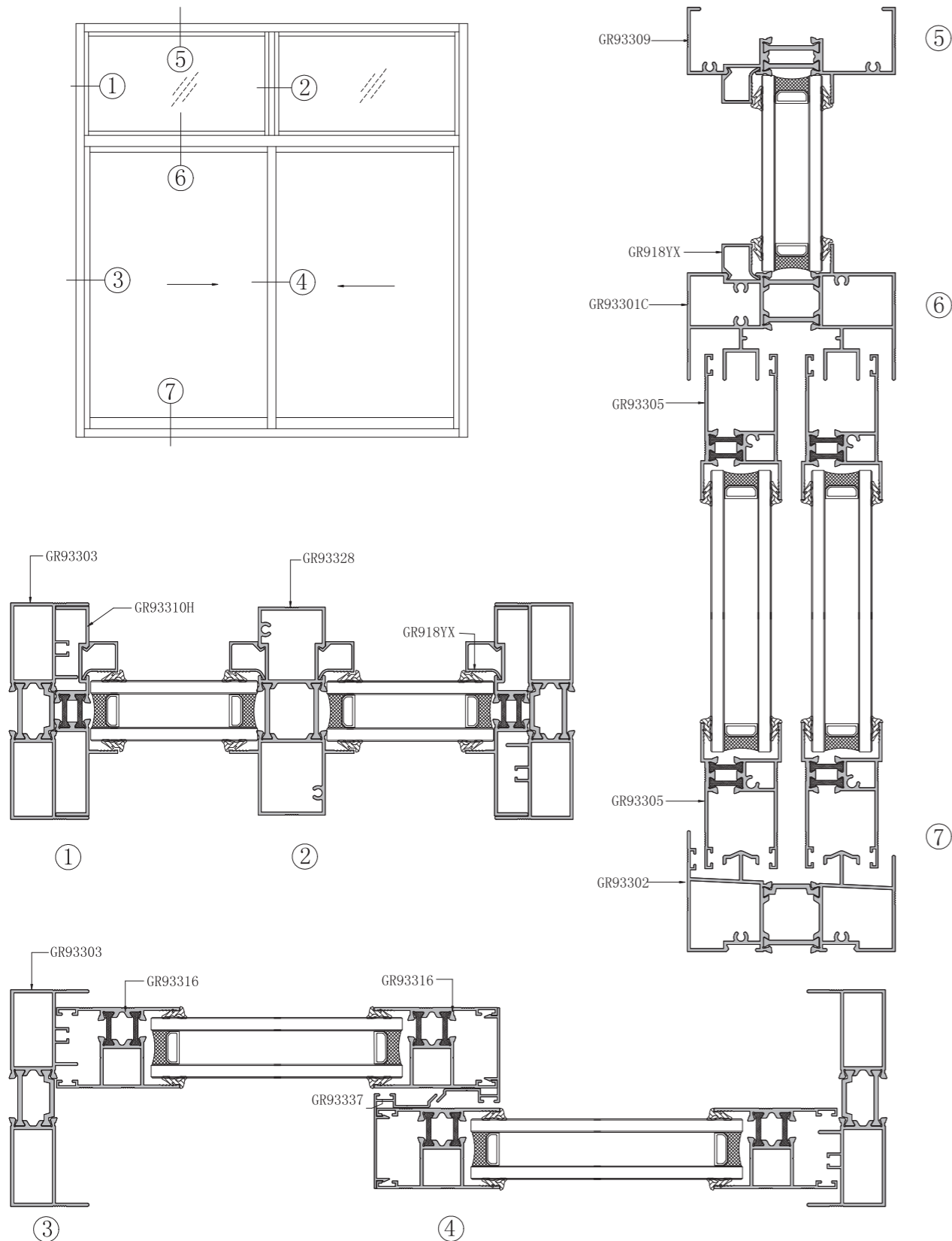

型号 Dwg NO.	GR93310H
名称 Profile	插板
壁厚(mm) Thickness	重量(kg/m) Weight
1.4	0.836

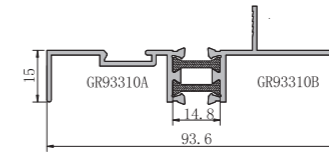

型号 Dwg NO.	GR93328
名称 Profile	中柱
壁厚(mm) Thickness	重量(kg/m) Weight
1.4	1.428

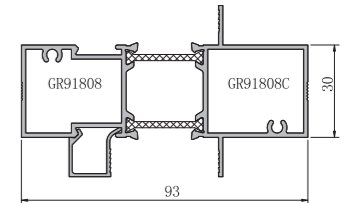

型号 Dwg NO.	GR93320
名称 Profile	反插板
壁厚(mm) Thickness	重量(kg/m) Weight
1.4	0.747

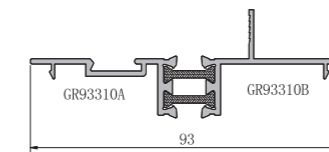

型号 Dwg NO.	GR93309
名称 Profile	上固定
壁厚(mm) Thickness	重量(kg/m) Weight
1.4	1.05

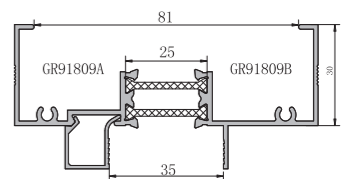

型号 Dwg NO.	GR93301C
名称 Profile	固上滑
壁厚(mm) Thickness	重量(kg/m) Weight
1.4	1.877

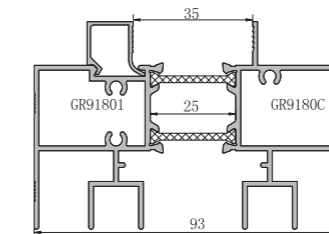

型号 Dwg NO.	GR93312
名称 Profile	连体固下滑
壁厚(mm) Thickness	重量(kg/m) Weight
1.4	1.807

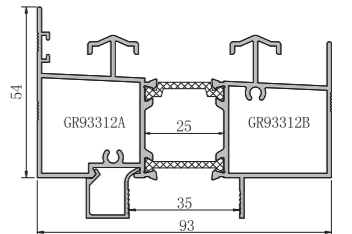

型号 Dwg NO.	GR93301
名称 Profile	上滑
壁厚(mm) Thickness	重量(kg/m) Weight
1.4	1.89

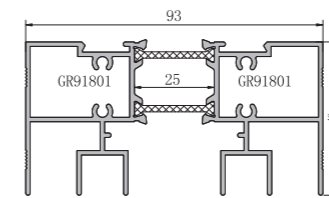

型号 Dwg NO.	GR93305
名称 Profile	上方
壁厚(mm) Thickness	重量(kg/m) Weight
1.4	0.949

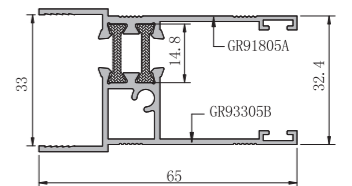

型号 Dwg NO.	GR93302
名称 Profile	下滑
壁厚(mm) Thickness	重量(kg/m) Weight
1.4	1.786

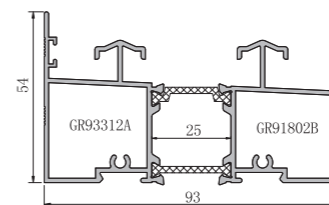

型号 Dwg NO.	GR93303
名称 Profile	边封
壁厚(mm) Thickness	重量(kg/m) Weight
1.4	1.292

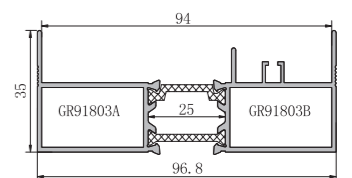

型号 Dwg NO.	GR918YX
名称 Profile	压线
壁厚(mm) Thickness	重量(kg/m) Weight
1.0	0.135

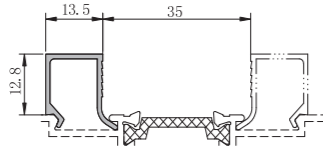

型号 Dwg NO.	GR93308
名称 Profile	中柱
壁厚(mm) Thickness	重量(kg/m) Weight
1.4	1.38

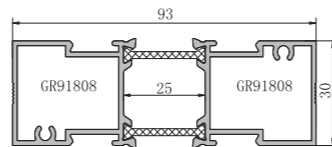

型号 Dwg NO.	GR93305
名称 Profile	下方
壁厚(mm) Thickness	重量(kg/m) Weight
1.4	0.949

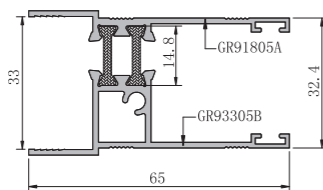

型号 Dwg NO.	GR93310
名称 Profile	插板
壁厚(mm) Thickness	重量(kg/m) Weight
1.4	0.82

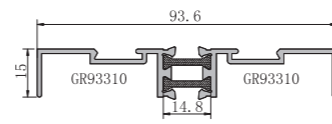

型号 Dwg NO.	GR93316
名称 Profile	光企
壁厚(mm) Thickness	重量(kg/m) Weight
1.4	0.913

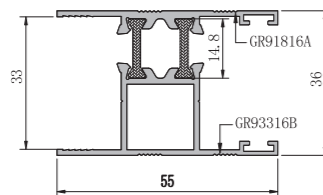

型号 Dwg NO.	GR93313
名称 Profile	双边封
壁厚(mm) Thickness	重量(kg/m) Weight
1.4	1.486

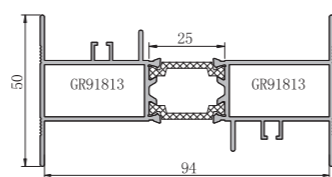

型号 Dwg NO.	GR93337
名称 Profile	勾企
壁厚(mm) Thickness	重量(kg/m) Weight
1.0	1.151

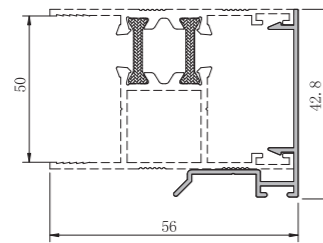

型号 Dwg NO.	100135
名称 Profile	135度转角
壁厚(mm) Thickness	重量(kg/m) Weight
1.4	1.056

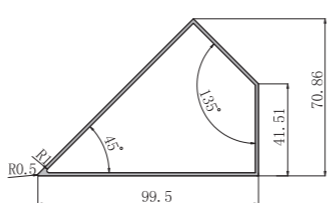

型号 Dwg NO.	BQ100-L011
名称 Profile	90度转角
壁厚(mm) Thickness	重量(kg/m) Weight
1.6	1.588

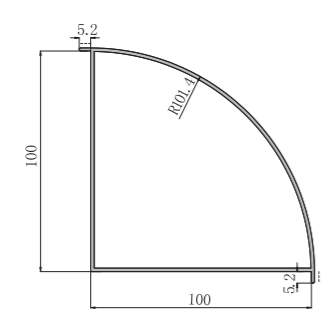

型号 Dwg NO.	KLT-1026
名称 Profile	90度转角
壁厚(mm) Thickness	重量(kg/m) Weight
1.6	2.868

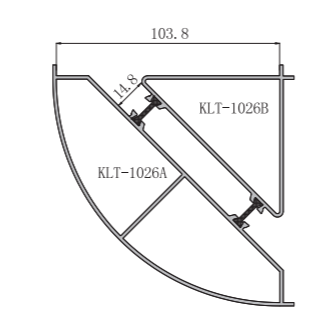

型号 Dwg NO.	KLT-1027
名称 Profile	135度转角
壁厚(mm) Thickness	重量(kg/m) Weight
1.6	2.05

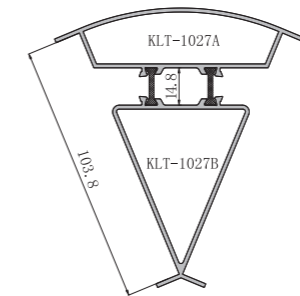

型号 Dwg NO.	GR98PG
名称 Profile	拼管
壁厚(mm) Thickness	重量(kg/m) Weight
1.4	1.122

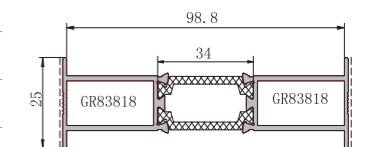

型号 Dwg NO.	
名称 Profile	隔热转角
壁厚(mm) Thickness	重量(kg/m) Weight

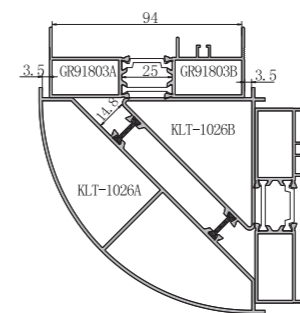

型号 Dwg NO.	
名称 Profile	隔热转角
壁厚(mm) Thickness	重量(kg/m) Weight

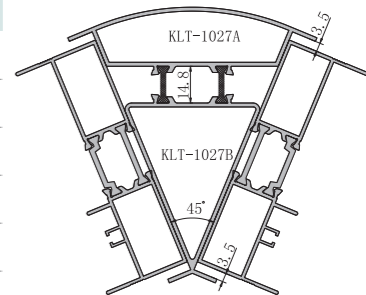

型号 Dwg NO.	FG78YX
名称 Profile	压线
壁厚(mm) Thickness	重量(kg/m) Weight
1.1	0.34

型号 Dwg NO.	
名称 Profile	
壁厚(mm) Thickness	重量(kg/m) Weight

型号 Dwg NO.	
名称 Profile	
壁厚(mm) Thickness	重量(kg/m) Weight

型号 Dwg NO.	
名称 Profile	
壁厚(mm) Thickness	重量(kg/m) Weight

型号 Dwg NO.	
名称 Profile	
壁厚(mm) Thickness	重量(kg/m) Weight

型号 Dwg NO.	
名称 Profile	
壁厚(mm) Thickness	重量(kg/m) Weight

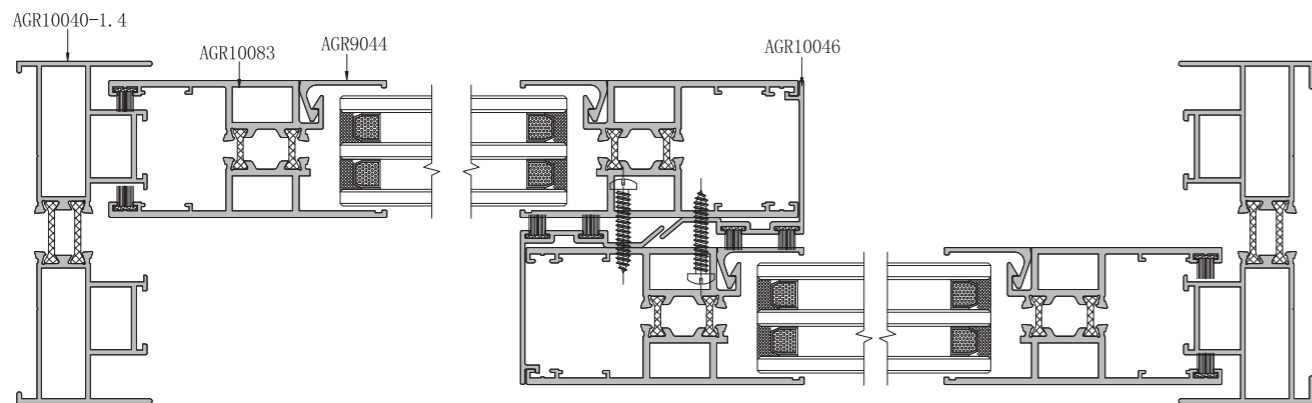
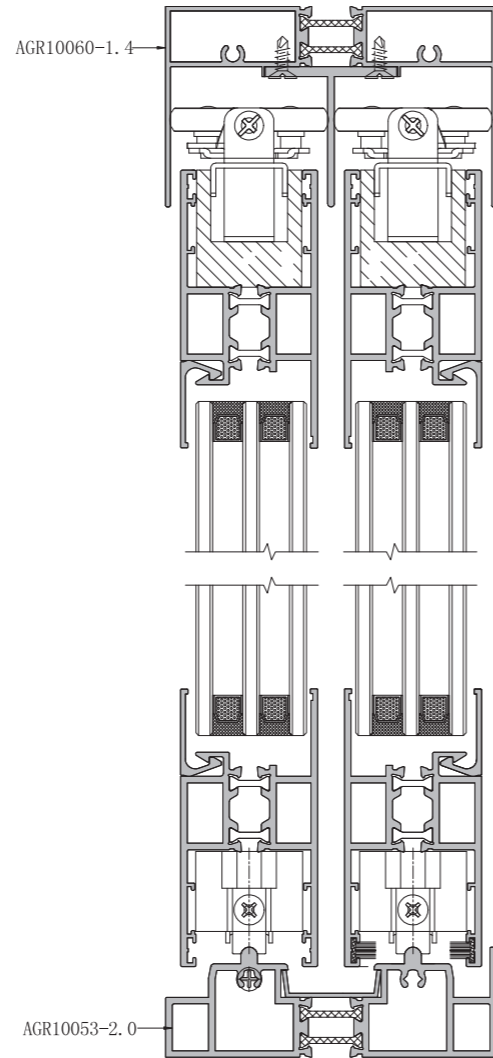
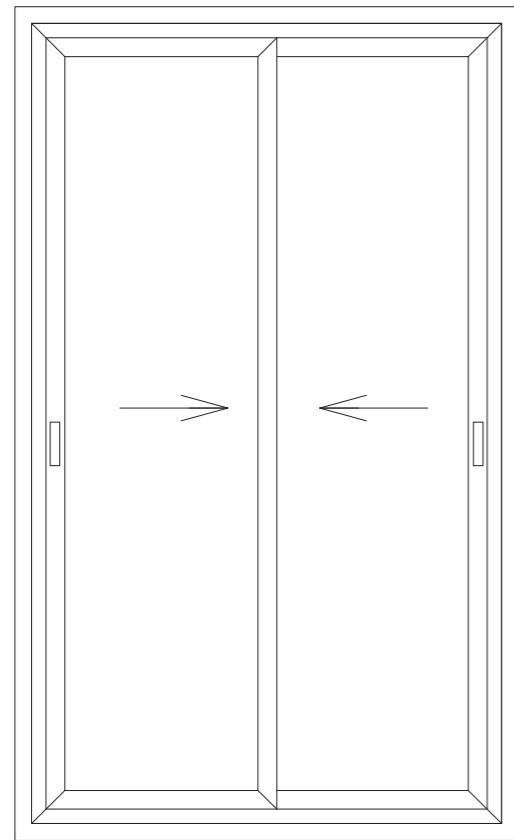

型号 Dwg NO.	AGR10031-2.0
名称 Profile	边封
壁厚(mm) Thickness	重量(kg/m) Weight
2.0	2.025

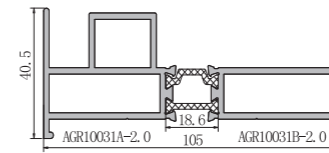

型号 Dwg NO.	AGR10053-2.0
名称 Profile	下滑
壁厚(mm) Thickness	重量(kg/m) Weight
2.0	2.102

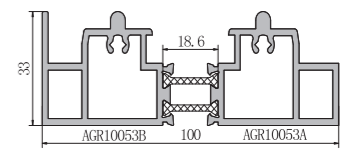

型号 Dwg NO.	AGR10067
名称 Profile	勾企
壁厚(mm) Thickness	重量(kg/m) Weight
2.0	2.102

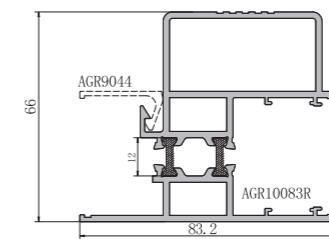

型号 Dwg NO.	AGR10040-1.4
名称 Profile	边框
壁厚(mm) Thickness	重量(kg/m) Weight
1.4	1.743

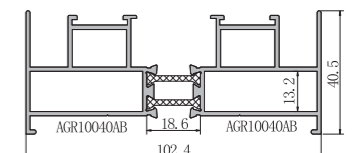

型号 Dwg NO.	AGR10060-1.4
名称 Profile	上滑
壁厚(mm) Thickness	重量(kg/m) Weight
1.4	1.516

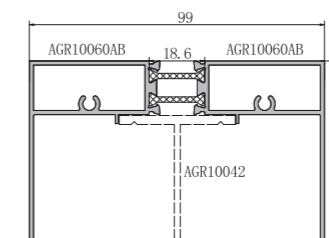

型号 Dwg NO.	AGR10033
名称 Profile	下滑
壁厚(mm) Thickness	重量(kg/m) Weight
2.0	2.287

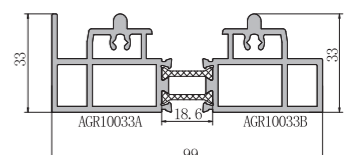

型号 Dwg NO.	AGR10083
名称 Profile	推拉门扇
壁厚(mm) Thickness	重量(kg/m) Weight
2.0	1.652

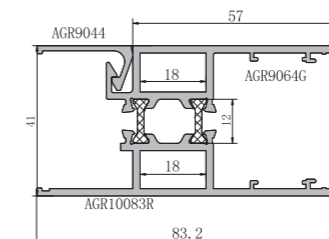

型号 Dwg NO.	AGR10046
名称 Profile	勾企
壁厚(mm) Thickness	重量(kg/m) Weight
1.4	0.398

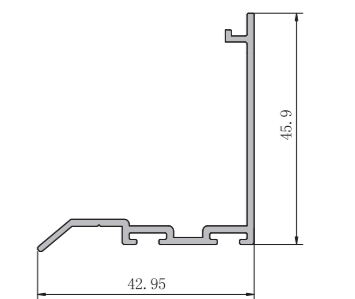

型号 Dwg NO.	AGR10042
名称 Profile	推拉门附条
壁厚(mm) Thickness	重量(kg/m) Weight
2.0	0.524

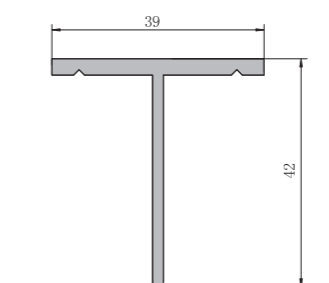

型号 Dwg NO.	AGR9044
名称 Profile	推拉门压线
壁厚(mm) Thickness	重量(kg/m) Weight
1.4	0.165

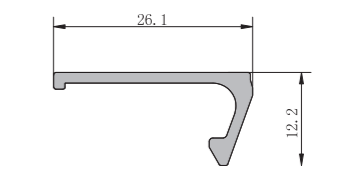

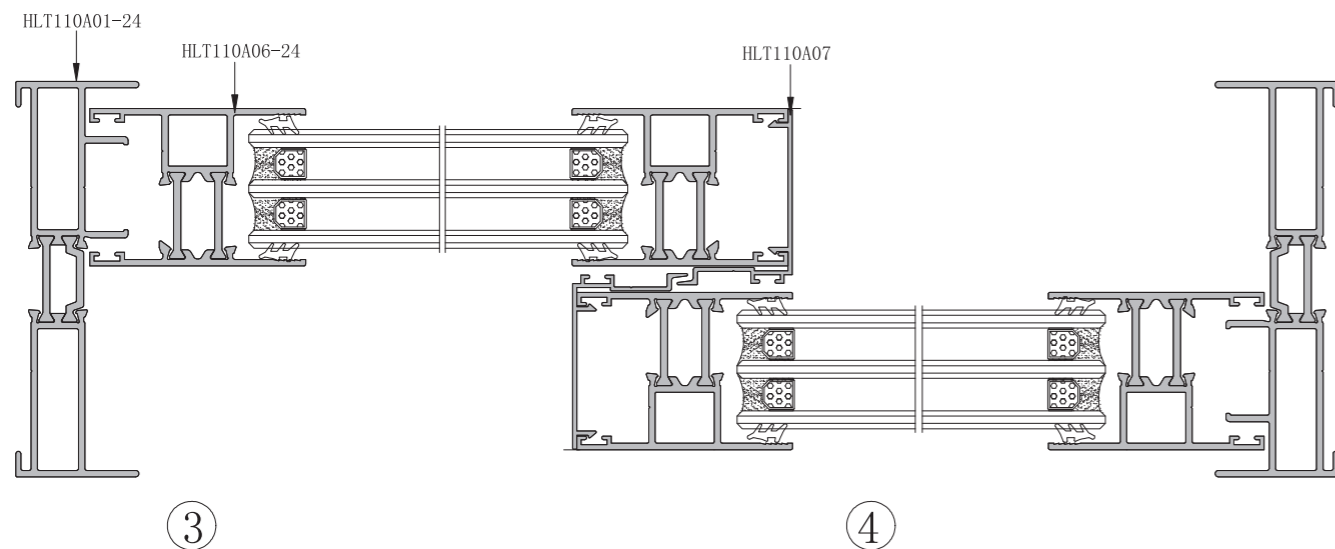
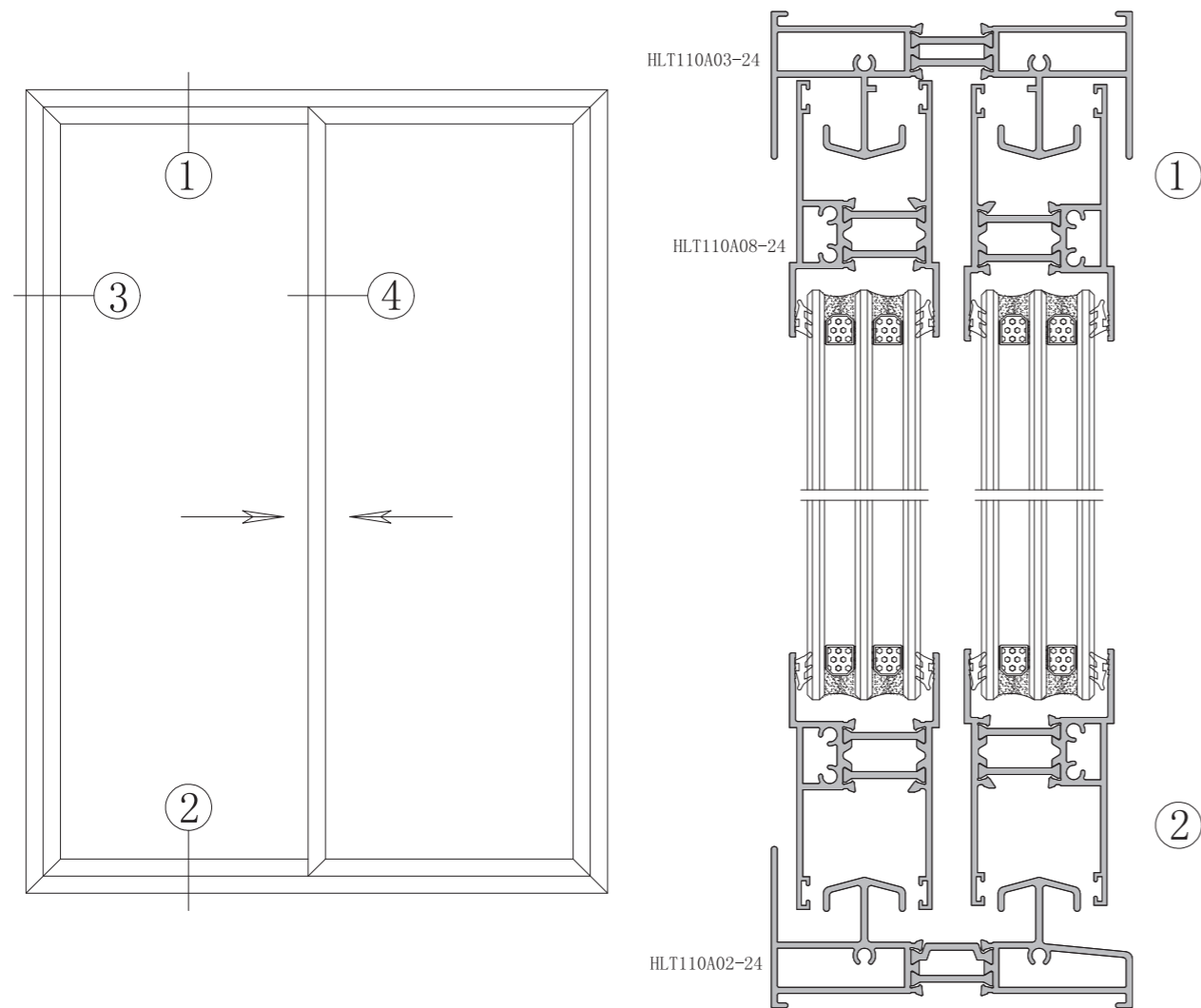

型号 Dwg NO.	HLT110A01-24
名称 Profile	边封
壁厚(mm) Thickness	重量(kg/m) Weight
1.8	1.686

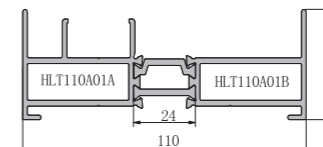

型号 Dwg NO.	HLT110A02-24
名称 Profile	下滑
壁厚(mm) Thickness	重量(kg/m) Weight
1.8	2.079

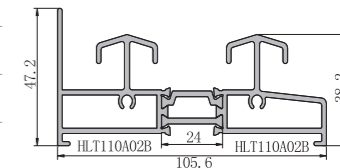

型号 Dwg NO.	HLT110A03-24
名称 Profile	平上滑
壁厚(mm) Thickness	重量(kg/m) Weight
1.8	2.234

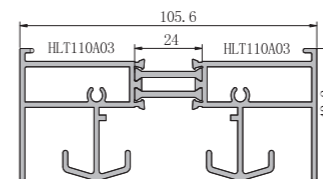

型号 Dwg NO.	HLT110A06-24
名称 Profile	光企
壁厚(mm) Thickness	重量(kg/m) Weight
1.8	1.152

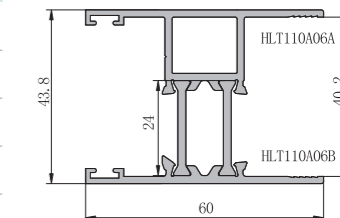

型号 Dwg NO.	HLT110A08-24
名称 Profile	下方
壁厚(mm) Thickness	重量(kg/m) Weight
1.8	1.325

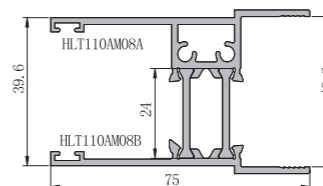

型号 Dwg NO.	HLT110A13ZH
名称 Profile	收口
壁厚(mm) Thickness	重量(kg/m) Weight
1.4	0.612

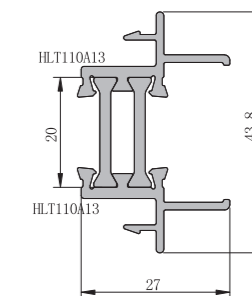

型号 Dwg NO.	HLT110A07
名称 Profile	勾企勾
壁厚(mm) Thickness	重量(kg/m) Weight
1.2	0.311

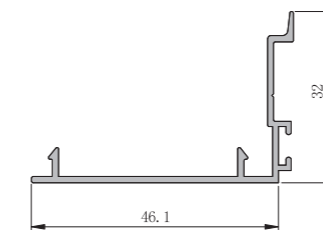

型号 Dwg NO.	HLT110CK
名称 Profile	传动槽口
壁厚(mm) Thickness	重量(kg/m) Weight
2.0	0.276

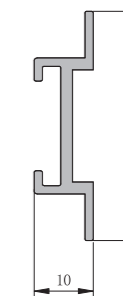

型号 Dwg NO.	
名称 Profile	
壁厚(mm) Thickness	重量(kg/m) Weight

型号 Dwg NO.	
名称 Profile	
壁厚(mm) Thickness	重量(kg/m) Weight

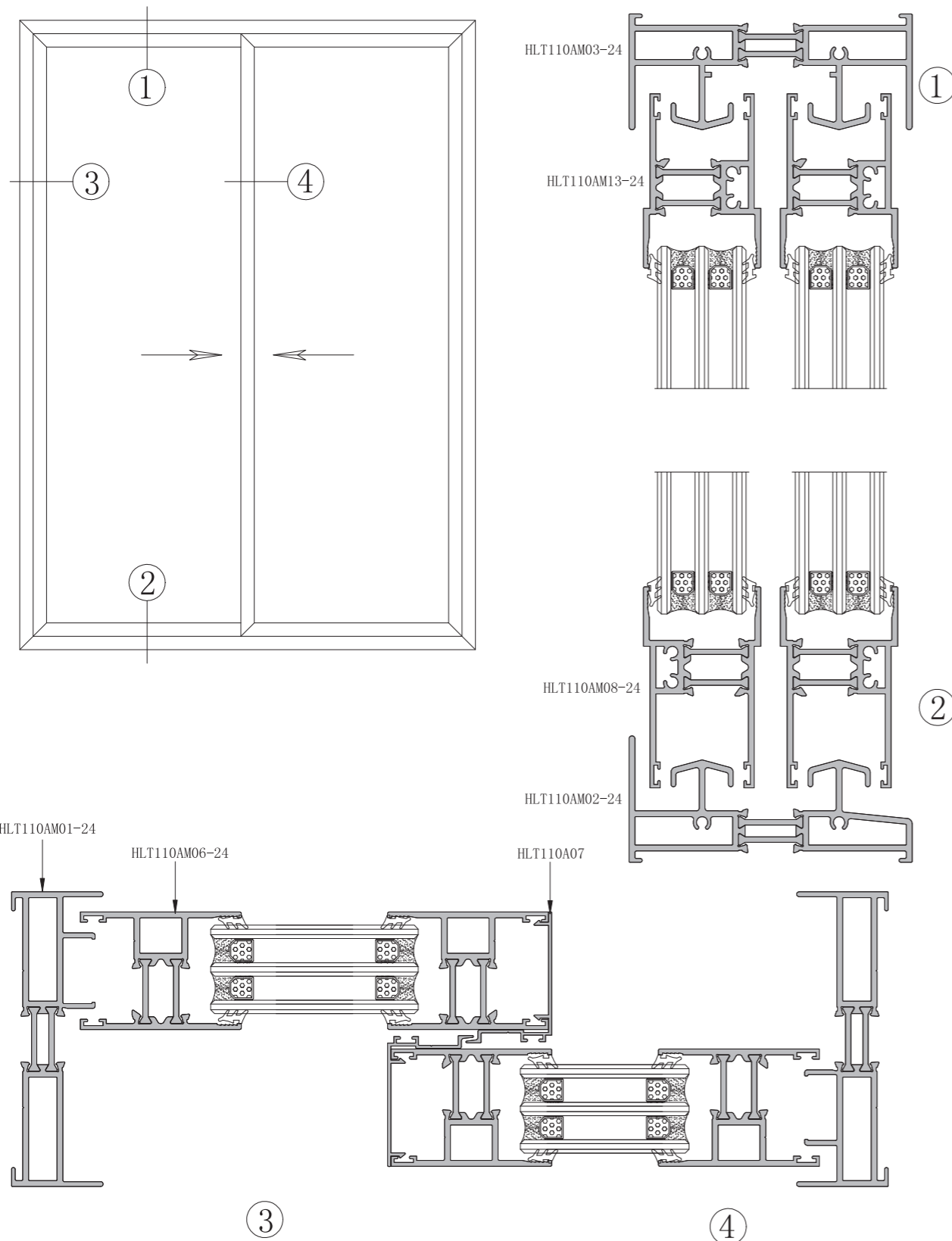

型号 Dwg NO.	HLT110AM01-24
名称 Profile	边封
壁厚(mm) Thickness	重量(kg/m) Weight
2.2	1.899

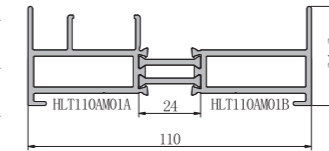

型号 Dwg NO.	HLT110AM02-24
名称 Profile	下滑
壁厚(mm) Thickness	重量(kg/m) Weight
2.2	2.364

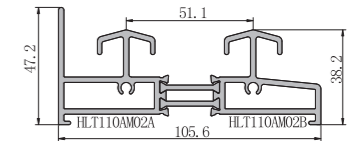

型号 Dwg NO.	HLT110AM03-24
名称 Profile	平上滑
壁厚(mm) Thickness	重量(kg/m) Weight
2.2	2.364

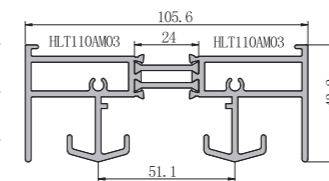

型号 Dwg NO.	HLT110AM06-24
名称 Profile	光企
壁厚(mm) Thickness	重量(kg/m) Weight
2.2	1.274

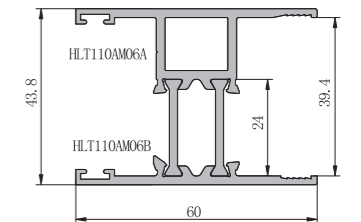

型号 Dwg NO.	HLT110AM08-24
名称 Profile	下方
壁厚(mm) Thickness	重量(kg/m) Weight
2.2	1.468

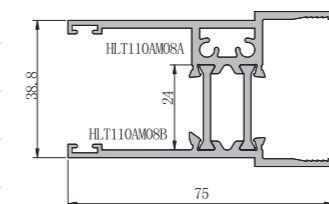

型号 Dwg NO.	HLT110AM13-24
名称 Profile	上方
壁厚(mm) Thickness	重量(kg/m) Weight
2.2	1.349

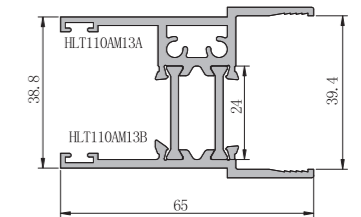

型号 Dwg NO.	HLT110A07
名称 Profile	勾企勾
壁厚(mm) Thickness	重量(kg/m) Weight
1.2	0.311

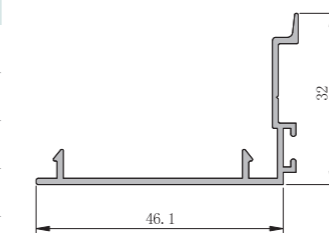

型号 Dwg NO.	HLT110CK
名称 Profile	传动槽口
壁厚(mm) Thickness	重量(kg/m) Weight
2.0	0.276

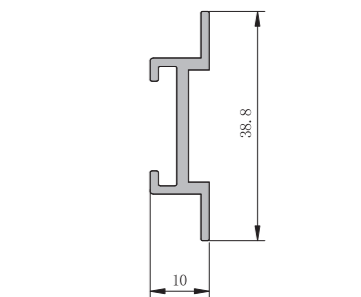

型号 Dwg NO.	
名称 Profile	
壁厚(mm) Thickness	重量(kg/m) Weight

型号 Dwg NO.	
名称 Profile	
壁厚(mm) Thickness	重量(kg/m) Weight

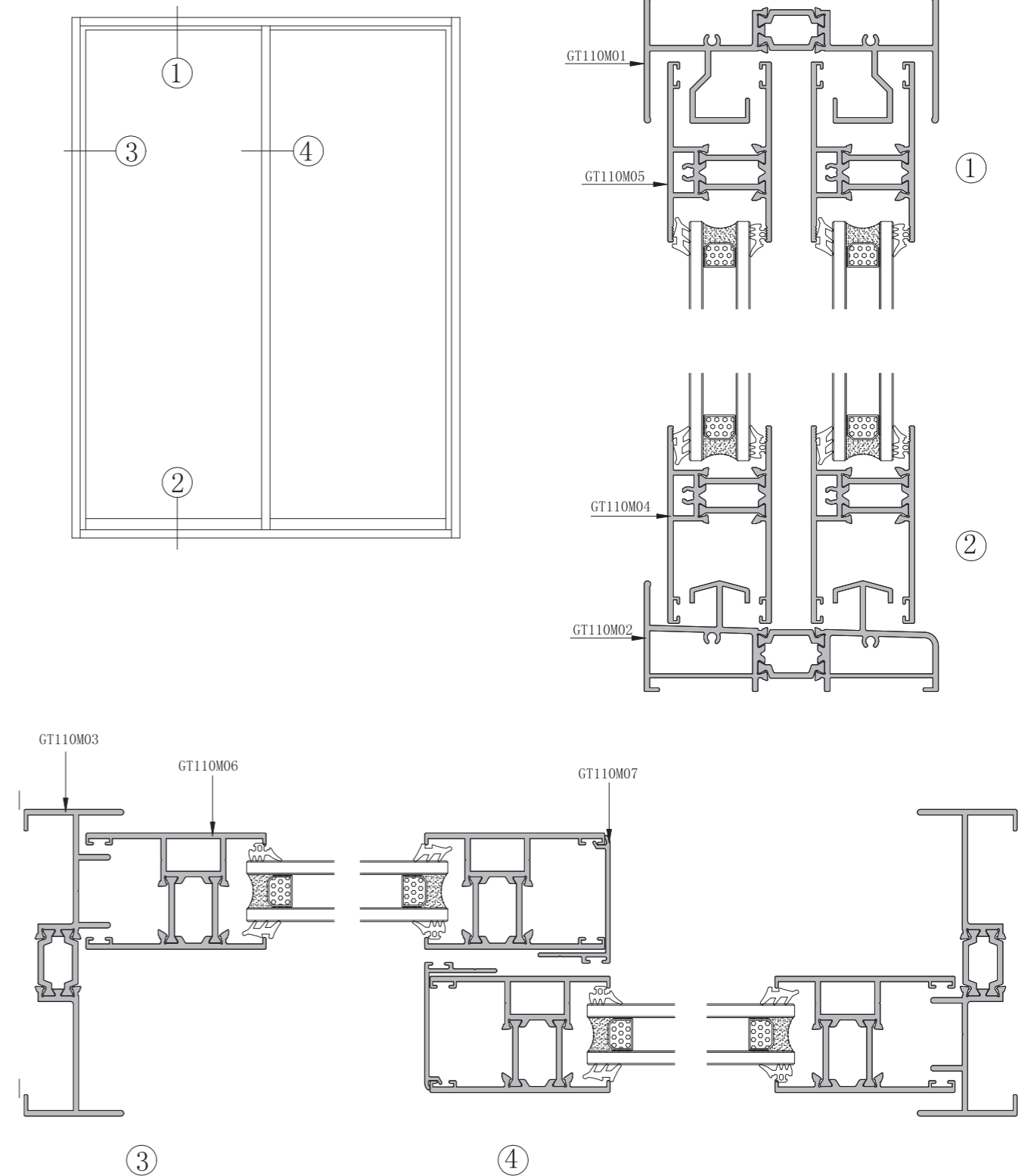
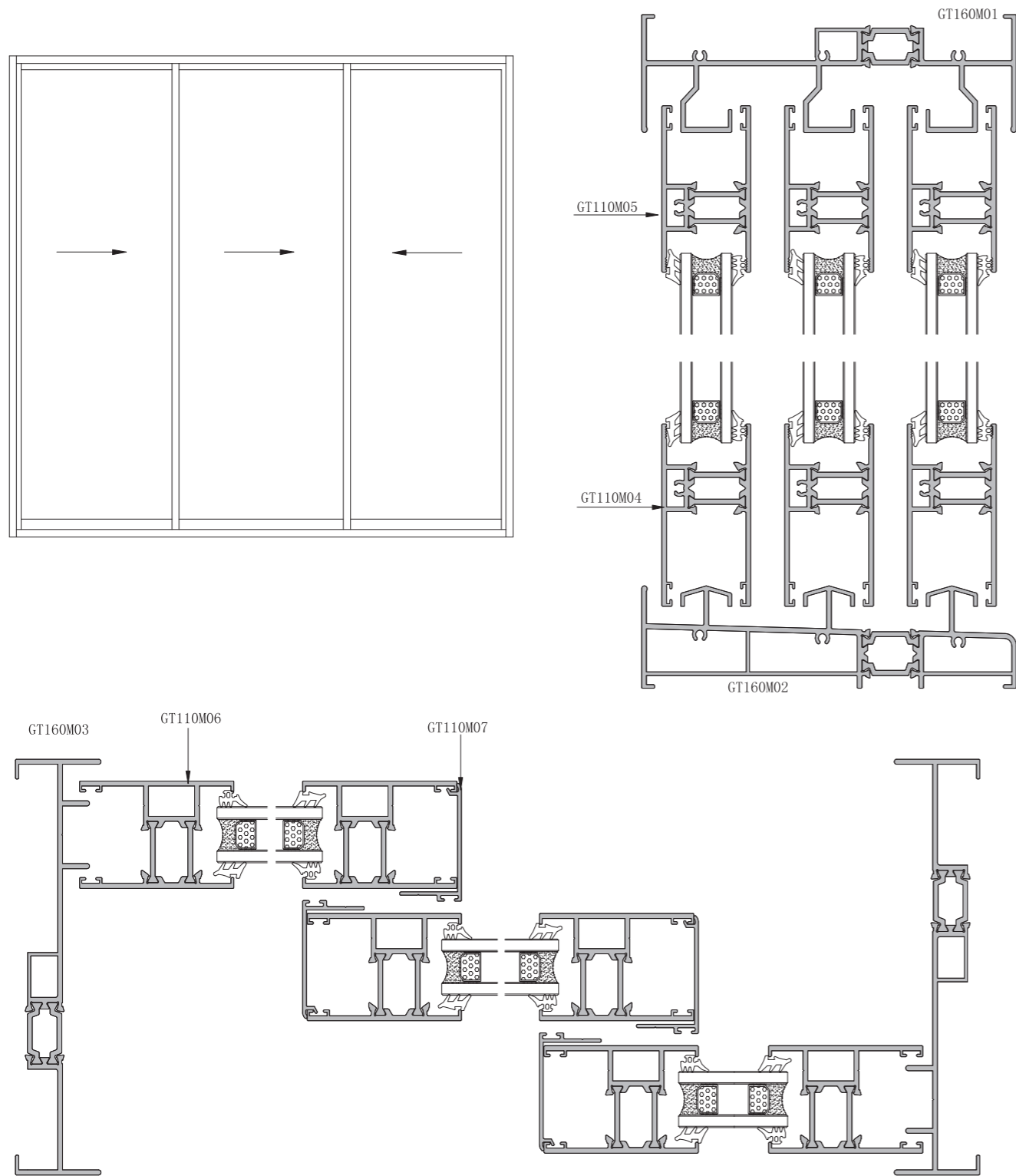

型号 Dwg NO.	GT110M01
名称 Profile	上滑
壁厚(mm) Thickness	重量(kg/m) Weight
2.0	2.012

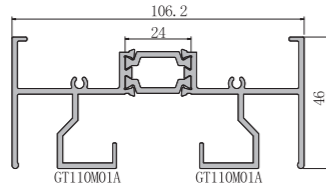

型号 Dwg NO.	GT160M01
名称 Profile	上滑
壁厚(mm) Thickness	重量(kg/m) Weight
2.0	2.079

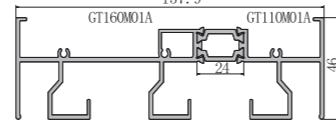

型号 Dwg NO.	GT110M02
名称 Profile	下滑
壁厚(mm) Thickness	重量(kg/m) Weight
2.0	2.079

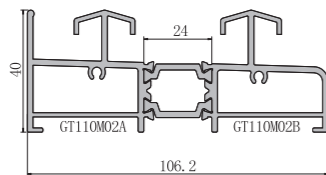

型号 Dwg NO.	GT160M02
名称 Profile	下滑
壁厚(mm) Thickness	重量(kg/m) Weight
2.0	2.85

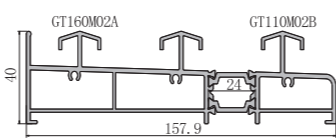

型号 Dwg NO.	GT110M03
名称 Profile	边封
壁厚(mm) Thickness	重量(kg/m) Weight
2.0	1.429

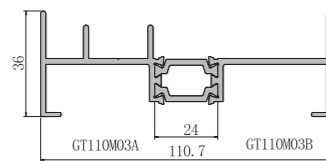

型号 Dwg NO.	GT160M03
名称 Profile	边封
壁厚(mm) Thickness	重量(kg/m) Weight
2.0	1.82

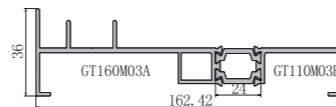

型号 Dwg NO.	GT160M13
名称 Profile	边封
壁厚(mm) Thickness	重量(kg/m) Weight
2.0	1.82

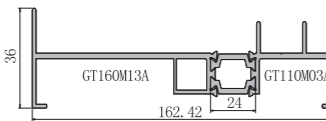

型号 Dwg NO.	GT110M04
名称 Profile	下方
壁厚(mm) Thickness	重量(kg/m) Weight
2.0	1.318

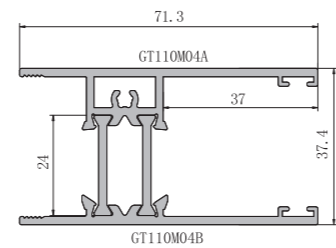

型号 Dwg NO.	GT110M05
名称 Profile	上方
壁厚(mm) Thickness	重量(kg/m) Weight
2.0	1.249

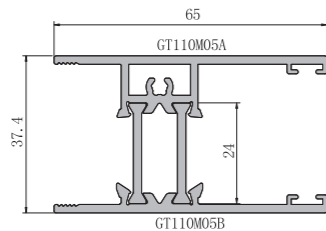

型号 Dwg NO.	GT110M06
名称 Profile	光企
壁厚(mm) Thickness	重量(kg/m) Weight
2.0	1.332

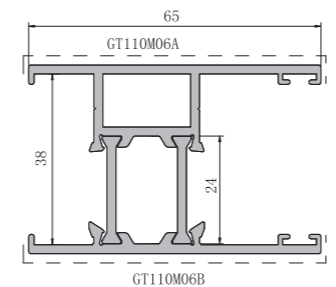

型号 Dwg NO.	GT110M07
名称 Profile	勾企盖板
壁厚(mm) Thickness	重量(kg/m) Weight
1.6	0.318

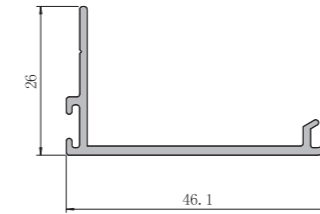

型号 Dwg NO.	GT110M012
名称 Profile	收口
壁厚(mm) Thickness	重量(kg/m) Weight
2.0	0.704

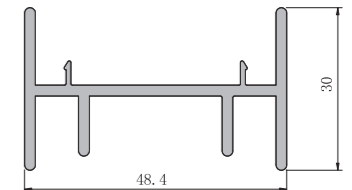

型号 Dwg NO.	
名称 Profile	
壁厚(mm) Thickness	重量(kg/m) Weight

型号 Dwg NO.	
名称 Profile	
壁厚(mm) Thickness	重量(kg/m) Weight

型号 Dwg NO.	GR7008
名称 Profile	收口
壁厚(mm) Thickness	重量(kg/m) Weight

型号 Dwg NO.	
名称 Profile	纱窗料
壁厚(mm) Thickness	重量(kg/m) Weight

型号 Dwg NO.	
名称 Profile	
壁厚(mm) Thickness	重量(kg/m) Weight

型号 Dwg NO.	
名称 Profile	
壁厚(mm) Thickness	重量(kg/m) Weight

型号 Dwg NO.	
名称 Profile	
壁厚(mm) Thickness	重量(kg/m) Weight

型号 Dwg NO.	
名称 Profile	
壁厚(mm) Thickness	重量(kg/m) Weight