

型号 Dwg NO.	GRDT6303
名称 Profile	边框
壁厚(mm) Thickness	重量(kg/m) Weight
2.0	2.15

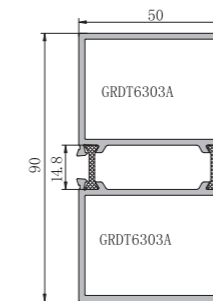

型号 Dwg NO.	GRDT6312B
名称 Profile	门框
壁厚(mm) Thickness	重量(kg/m) Weight
2.0	1.605

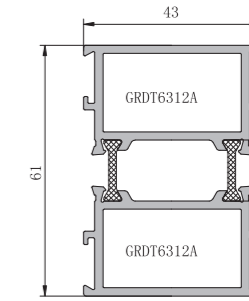

型号 Dwg NO.	GRDT6305B
名称 Profile	光企
壁厚(mm) Thickness	重量(kg/m) Weight
2.0	2.081

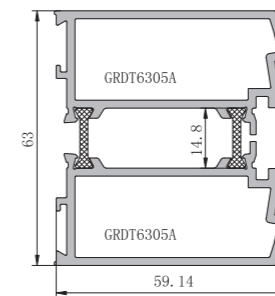

型号 Dwg NO.	GRDT6306B
名称 Profile	上方
壁厚(mm) Thickness	重量(kg/m) Weight
2.0	1.838

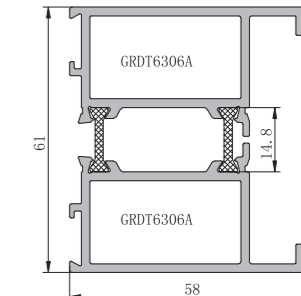

型号 Dwg NO.	GRDT6308B
名称 Profile	门中框
壁厚(mm) Thickness	重量(kg/m) Weight
2.0	2.154

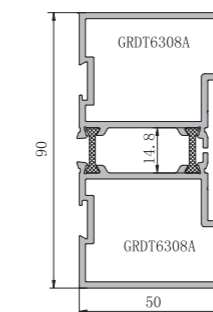

型号 Dwg NO.	GRDT6307B
名称 Profile	门扇
壁厚(mm) Thickness	重量(kg/m) Weight
2.0	2.085

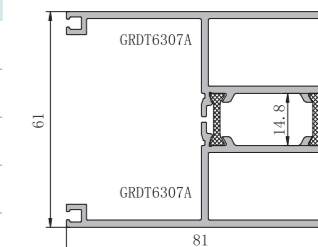

型号 Dwg NO.	GRDT6304
名称 Profile	门中框
壁厚(mm) Thickness	重量(kg/m) Weight
2.0	2.238

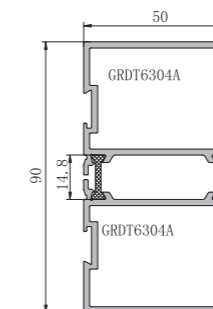

型号 Dwg NO.	GRDT6309
名称 Profile	PVC板
壁厚(mm) Thickness	重量(kg/m) Weight
1.2	0.18

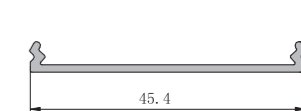

型号 Dwg NO.	GRDT6310
名称 Profile	光企插件
壁厚(mm) Thickness	重量(kg/m) Weight
	0.115

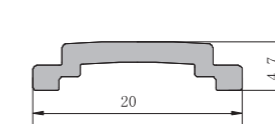

型号 Dwg NO.	GRDT6302
名称 Profile	封口条
壁厚(mm) Thickness	重量(kg/m) Weight
	0.053

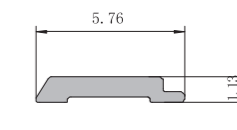

型号 Dwg NO.	GRDT6301
名称 Profile	压线
壁厚(mm) Thickness	重量(kg/m) Weight
0.9	0.144

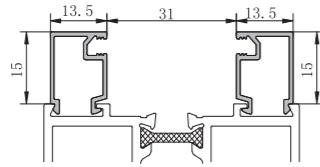

型号 Dwg NO.	GRDT6330
名称 Profile	压线
壁厚(mm) Thickness	重量(kg/m) Weight
0.9	0.16

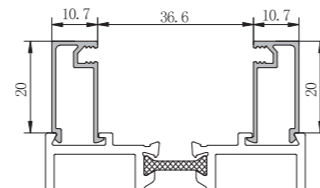

型号 Dwg NO.	GRDT6334
名称 Profile	压线
壁厚(mm) Thickness	重量(kg/m) Weight
0.9	0.116

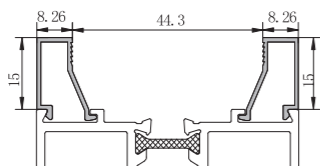

型号 Dwg NO.	
名称 Profile	
壁厚(mm) Thickness	重量(kg/m) Weight

型号 Dwg NO.	
名称 Profile	
壁厚(mm) Thickness	重量(kg/m) Weight

型号 Dwg NO.	
名称 Profile	
壁厚(mm) Thickness	重量(kg/m) Weight

型号 Dwg NO.	
名称 Profile	
壁厚(mm) Thickness	重量(kg/m) Weight

型号 Dwg NO.	
名称 Profile	
壁厚(mm) Thickness	重量(kg/m) Weight

型号 Dwg NO.	
名称 Profile	
壁厚(mm) Thickness	重量(kg/m) Weight

型号 Dwg NO.	
名称 Profile	
壁厚(mm) Thickness	重量(kg/m) Weight

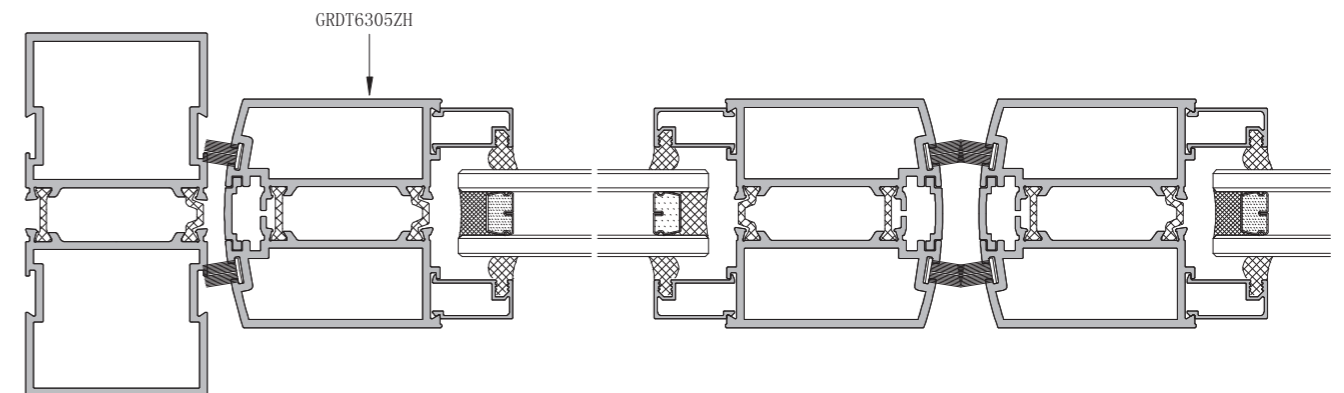
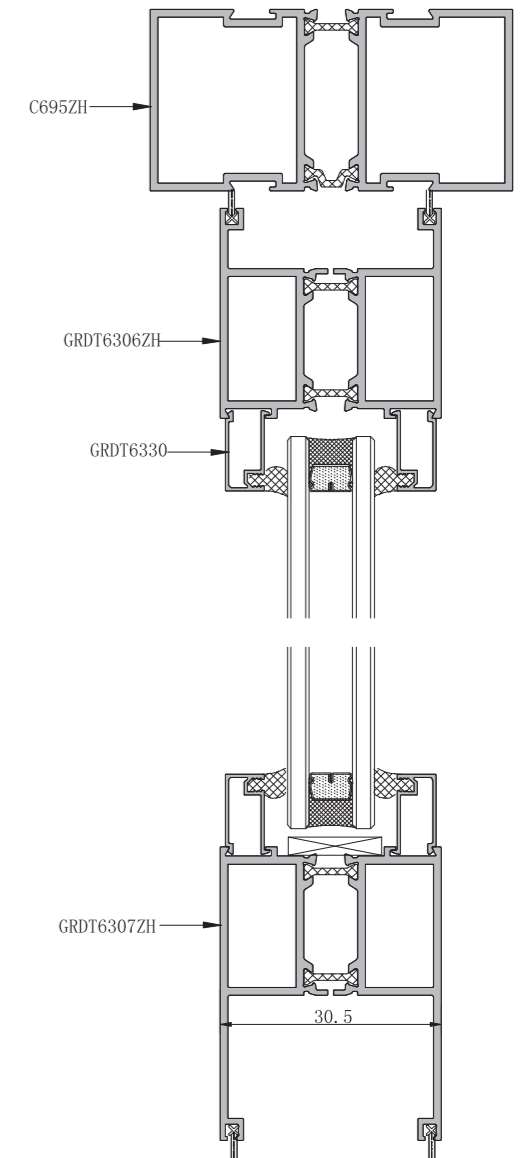
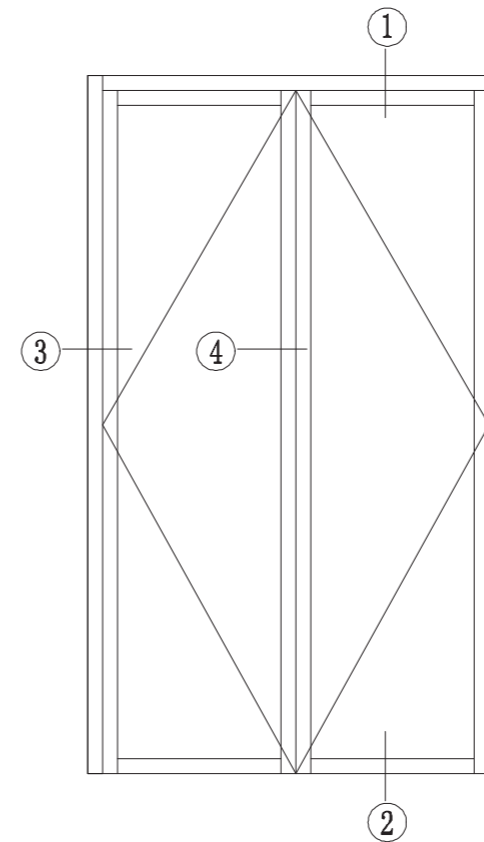

型号 Dwg NO.	C695ZH
名称 Profile	中柱
壁厚(mm) Thickness	重量(kg/m) Weight
2.2	2.49

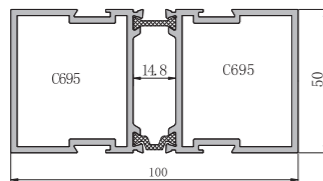

型号 Dwg NO.	GRDT6341ZH
名称 Profile	边框
壁厚(mm) Thickness	重量(kg/m) Weight
2.2	2.417

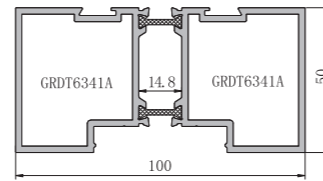

型号 Dwg NO.	GRDT6330
名称 Profile	压线
壁厚(mm) Thickness	重量(kg/m) Weight
0.9	0.158

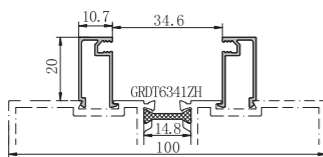

型号 Dwg NO.	GRDT6305ZH
名称 Profile	光企
壁厚(mm) Thickness	重量(kg/m) Weight
2.2	2.234

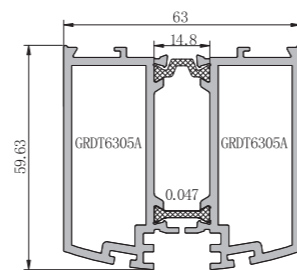

型号 Dwg NO.	GRDT6307ZH
名称 Profile	门下方
壁厚(mm) Thickness	重量(kg/m) Weight
2.2	2.231

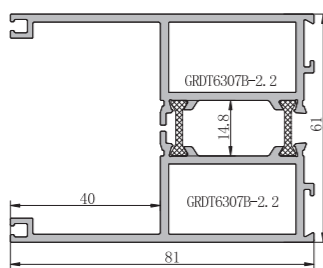

型号 Dwg NO.	GRDT6306ZH
名称 Profile	门上方
壁厚(mm) Thickness	重量(kg/m) Weight
2.2	1.959

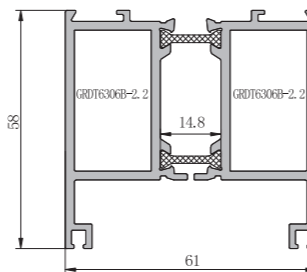

型号 Dwg NO.	GRDTZT63ZH
名称 Profile	扇中框
壁厚(mm) Thickness	重量(kg/m) Weight
2.2	1.721

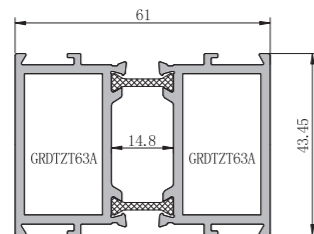

型号 Dwg NO.	
名称 Profile	
壁厚(mm) Thickness	重量(kg/m) Weight

型号 Dwg NO.	
名称 Profile	
壁厚(mm) Thickness	重量(kg/m) Weight

型号 Dwg NO.	
名称 Profile	
壁厚(mm) Thickness	重量(kg/m) Weight

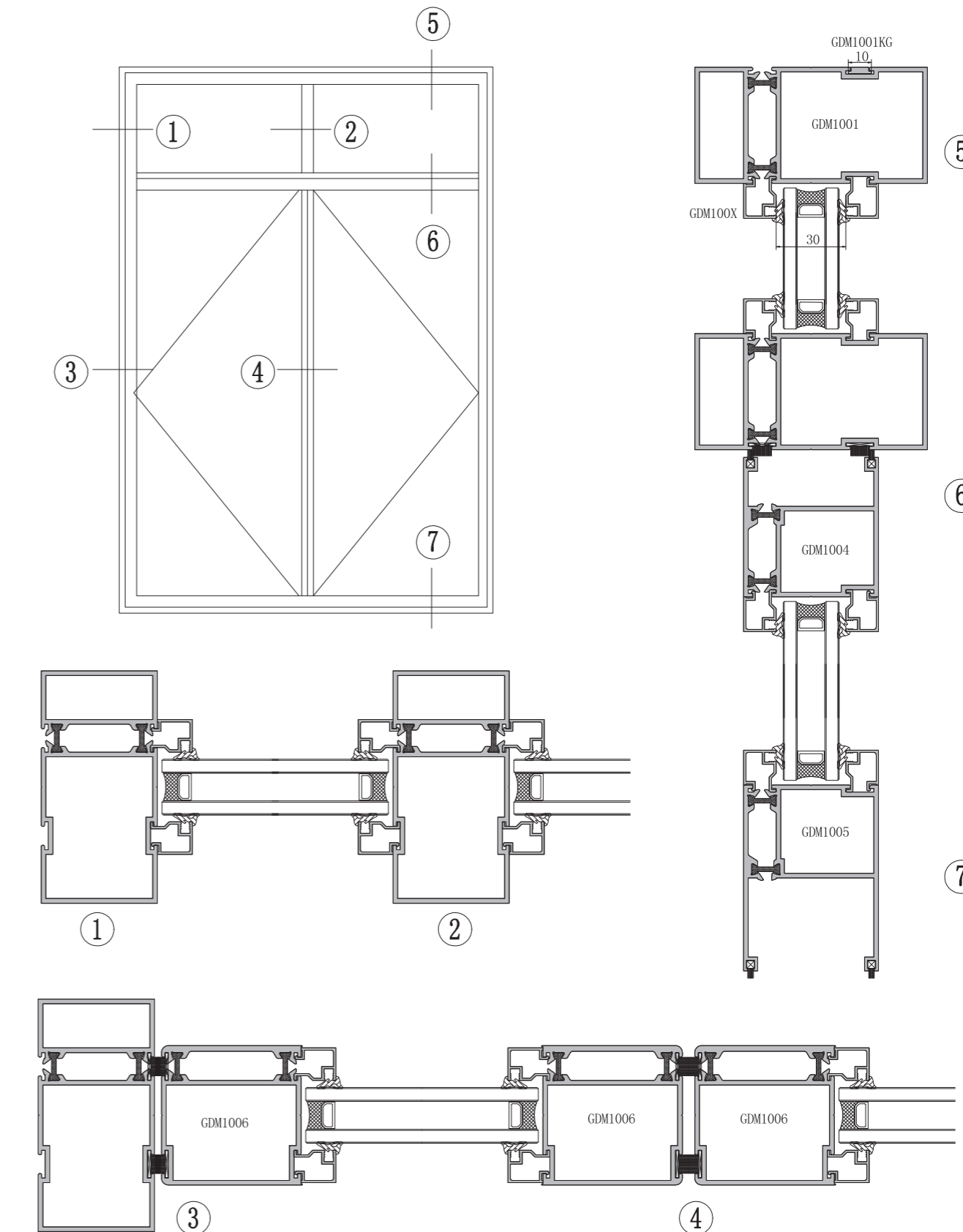

型号 Dwg NO.	GDM1004
名称 Profile	门上方
壁厚(mm) Thickness	重量(kg/m) Weight
2.0	1.664

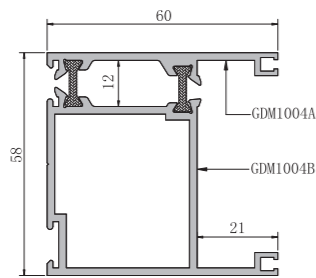

型号 Dwg NO.	GDM1006
名称 Profile	门毛企
壁厚(mm) Thickness	重量(kg/m) Weight
2.0	1.881

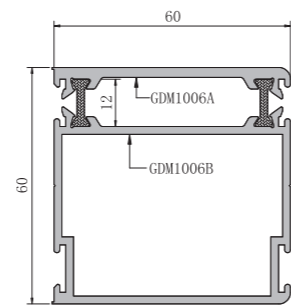

型号 Dwg NO.	GDM1005
名称 Profile	门下方
壁厚(mm) Thickness	重量(kg/m) Weight
2.0	1.887

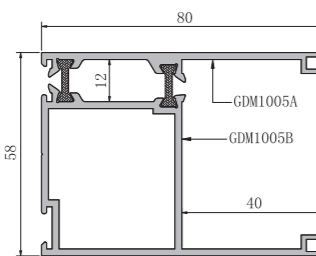

型号 Dwg NO.	GDM1001
名称 Profile	门框、中柱
壁厚(mm) Thickness	重量(kg/m) Weight
2.0	2.324

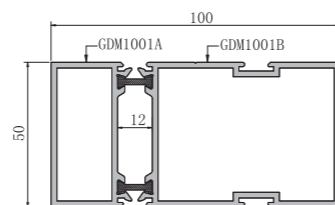

型号 Dwg NO.	GDM100X
名称 Profile	门压线
壁厚(mm) Thickness	重量(kg/m) Weight
1.0	0.167

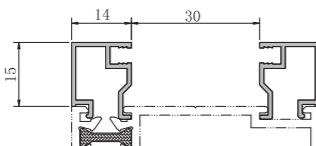

型号 Dwg NO.	GDM100XA
名称 Profile	门压线
壁厚(mm) Thickness	重量(kg/m) Weight
1.0	0.135

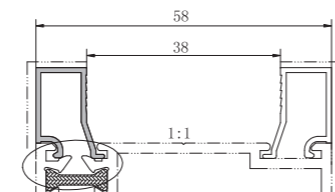

型号 Dwg NO.	GDM100XB
名称 Profile	门压线
壁厚(mm) Thickness	重量(kg/m) Weight
1.0	0.199

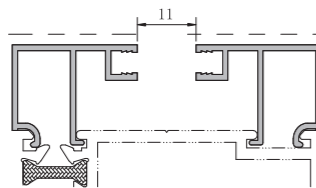

型号 Dwg NO.	GDM1001KG
名称 Profile	扣盖
壁厚(mm) Thickness	重量(kg/m) Weight
	0.064

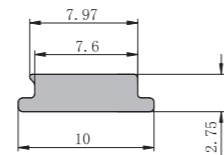

型号 Dwg NO.	
名称 Profile	
壁厚(mm) Thickness	重量(kg/m) Weight

型号 Dwg NO.	
名称 Profile	
壁厚(mm) Thickness	重量(kg/m) Weight

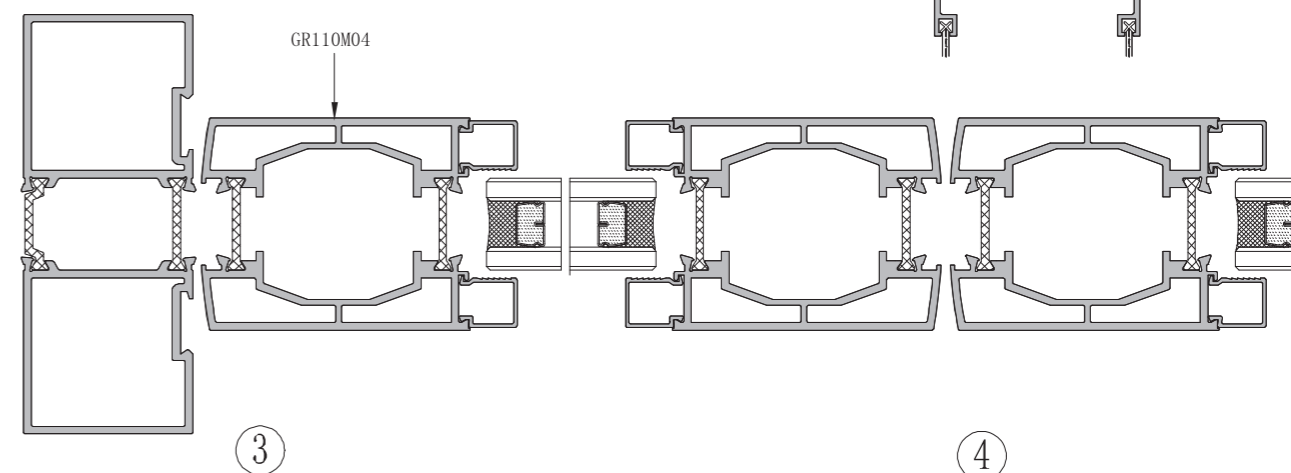
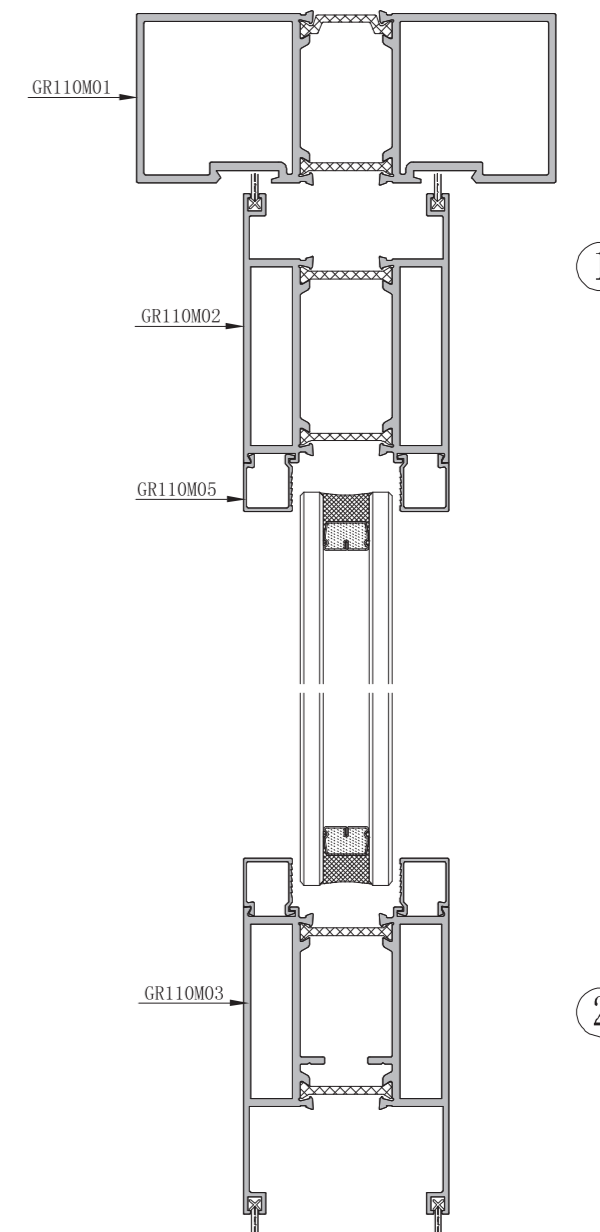
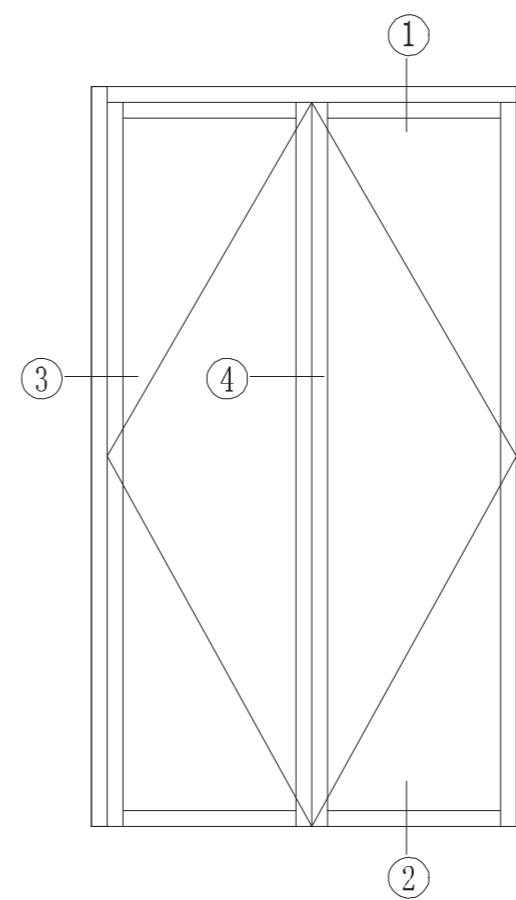

型号 Dwg NO.	GR110M01
名称 Profile	门框
壁厚(mm) Thickness	重量(kg/m) Weight
2.0	2.211

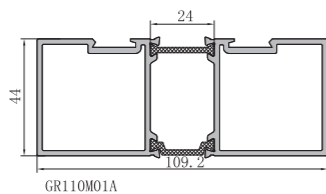

型号 Dwg NO.	GR110M02
名称 Profile	上方
壁厚(mm) Thickness	重量(kg/m) Weight
2.0	1.868

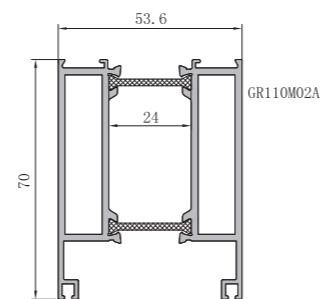

型号 Dwg NO.	GR110M03
名称 Profile	下方
壁厚(mm) Thickness	重量(kg/m) Weight
2.0	2.01

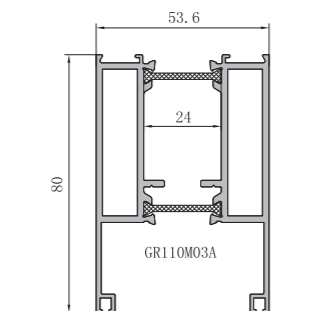

型号 Dwg NO.	GR110M04
名称 Profile	光企
壁厚(mm) Thickness	重量(kg/m) Weight
2.0	2.258

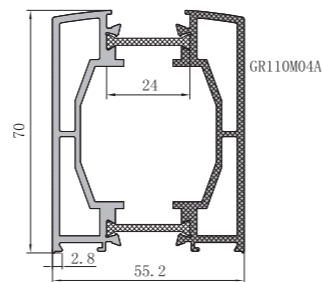

型号 Dwg NO.	GR110M05
名称 Profile	压线
壁厚(mm) Thickness	重量(kg/m) Weight
0.9	0.11

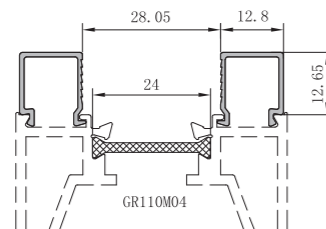

型号 Dwg NO.	
名称 Profile	
壁厚(mm) Thickness	重量(kg/m) Weight

型号 Dwg NO.	
名称 Profile	
壁厚(mm) Thickness	重量(kg/m) Weight

型号 Dwg NO.	
名称 Profile	
壁厚(mm) Thickness	重量(kg/m) Weight

型号 Dwg NO.	
名称 Profile	
壁厚(mm) Thickness	重量(kg/m) Weight

型号 Dwg NO.	
名称 Profile	
壁厚(mm) Thickness	重量(kg/m) Weight

