

更换14.8隔热条为55系列

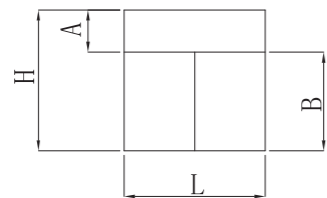

H=1500mm
L=1500mm
A=500mm
B=1000mm

用料清单 (仅供参考)

名称	型号	公式	长度 (mm)	每米重量	数量	重量(kg)
横边框	GR5541	L	1500	1.091	2	3.273
竖边框	GR5541	H	1500	1.091	2	3.273
横中梃	OR5542	L-56	1444	1.293	1	1.867
竖中梃	GR5542	B-38	962	1.293	1	1.244
上固窗横压线	GR5506	L-66	1434	0.243	2	0.697
上固窗竖压线	GR5506	A-92	408	0.243	2	0.198
侧固窗横压线	GR5506	L/2-48	702	0.243	2	0.341
侧固窗竖压线	CR5506	B-92	908	0.243	2	0.441
窗扇横料	GR5543T	L/2-36	714	1.309	2	1.869
窗扇竖料	GR5543T	B-36	964	1.309	2	2.524
窗扇横压线	CR5506	L/2-130.8	619.2	0.243	2	0.301
窗扇竖压线	GR5506	B-174.8	825.2	0.243	2	0.401
框角码 (内)	GR5507	19.9	19.9	1.794	4	0.143
框角码 (外)	GR5507	13.7	13.7	1.794	4	0.098
扇角码 (内)	GR5507	28.9	28.9	1.794	4	0.207
扇角码 (外)	GR5507	7.7	7.7	1.794	4	0.055
合计 (kg)						16.933
铝窗面积	宽1.5米	高1.5米				2.25m ²
单位重量						16.933/2.25 ≈ 7.526kg/m ²

更换20隔热条为60系列

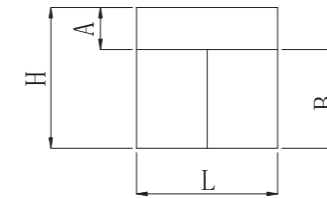

H=1500mm
L=1500mm
A=500mm
B=1000mm

用料清单 (仅供参考)

名称	型号	公式	长度 (mm)	每米重量	数量	重量(kg)
横边框	GR556041	L	1500	1.119	2	3.357
竖边框	GR556041	H	1500	1.119	2	3.357
横中梃	OR556012	L-56	1444	1.275	1	1.841
竖中梃	OR556012	B-38	962	1.275	1	1.227
上固窗横压线	GR5546	L-66	1434	0.257	2	0.737
上固窗竖压线	GR5546	A-92	408	0.257	2	0.210
侧固窗横压线	GR5546	L/2-48	702	0.257	2	0.361
侧固窗竖压线	GR5546	B-92	908	0.257	2	0.467
窗扇横料	GR556043T	L/2-36	714	1.337	2	1.909
窗扇竖料	GR556043T	B-36	964	1.337	2	2.578
窗扇横压线	GR5546	L/2-130.8	619.2	0.257	2	0.318
窗扇竖压线	GR5546	B-174.8	825.2	0.257	2	0.424
框角码 (内)	GR5507	19.9	19.9	1.794	4	0.143
框角码 (外)	GR5507	13.7	13.7	1.794	4	0.098
扇角码 (内)	GR5507	28.9	28.9	1.794	4	0.207
扇角码 (外)	GR5507	7.7	7.7	1.794	4	0.055
合计 (kg)						17.289
铝窗面积	宽1.5米	高1.5米				2.25m ²
单位重量						17.289/2.25 ≈ 7.684kg/m ²

更换24隔热条为65系列

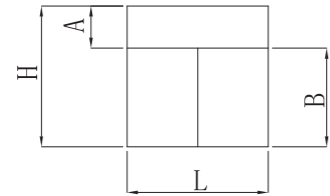

H=1500mm
L=1500mm
A=500mm
B=1000mm

用料清单 (仅供参考)

名称	型号	公式	长度 (mm)	每米重量	数量	重量(kg)
横边框	GR556571	L	1500	1.141	2	3.423
竖边框	GR556571	H	1500	1.141	2	3.423
横中梃	GR556572	L-56	1444	1.297	1	1.873
竖中梃	GR556572	B-38	962	1.297	1	1.248
上固窗横压线	GR5546	L-66	1434	0.257	2	0.737
上固窗竖压线	GR5546	A-92	408	0.257	2	0.210
侧固窗横压线	GR5546	L/2-48	702	0.257	2	0.361
侧固窗竖压线	GR5546	B-92	908	0.257	2	0.467
窗扇横料	GR556573	L/2-36	714	1.343	2	1.918
窗扇竖料	GR556573	B36	964	1.343	2	2.589
窗扇横压线	GR5546	L/2-130.8	619.2	0.257	2	0.318
窗扇竖压线	GR5546	B-174.8	825.2	0.257	2	0.424
框角码 (内)	GR5507	19.9	19.9	1.794	4	0.143
框角码 (外)	GR5507	13.7	13.7	1.794	4	0.098
扇角码 (内)	GR5507	28.9	28.9	1.794	4	0.207
扇角码 (外)	GR5507	7.7	7.7	1.794	4	0.055
合计 (kg)						17.494
铝窗面积	宽1.5米	高1.5米				2.25m ²
单位重量						17.494/2.25 ≈ 7.775kg/m ²

更换25隔热条为66系列

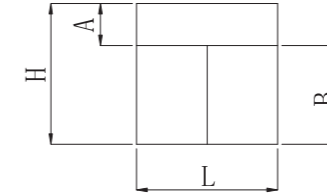

H=1500mm
L=1500mm
A=500mm
B=1000mm

用料清单 (仅供参考)

名称	型号	公式	长度 (mm)	每米重量	数量	重量(kg)
横边框	GR556541	L	1500	1.146	2	3.438
竖边框	GR556541	H	1500	1.146	2	3.438
横中梃	GR556512	L-56	1444	1.302	1	1.880
竖中梃	GR556512	B-38	962	1.302	1	1.253
上固窗横压线	GR5546	L-66	1434	0.257	2	0.737
上固窗竖压线	GR5546	A-92	408	0.257	2	0.210
侧固窗横压线	GR5546	L/2-48	702	0.257	2	0.361
侧固窗竖压线	GR5546	B-92	908	0.257	2	0.467
窗扇横料	GR556543	L/2-36	714	1.348	2	1.925
窗扇竖料	GR556543	B-36	964	1.348	2	2.599
窗扇横压线	GR5546	L/2-130.8	619.2	0.257	2	0.318
窗扇竖压线	GR5546	B-174.8	825.2	0.257	2	0.424
框角码 (内)	GR5507	19.9	19.9	1.794	4	0.143
框角码 (外)	GR5507	13.7	13.7	1.794	4	0.098
扇角码 (内)	GR5507	28.9	28.9	1.794	4	0.207
扇角码 (外)	GR5507	7.7	7.7	1.794	4	0.055
合计 (kg)						17.553
铝窗面积	宽1.5米	高1.5米				2.25m ²
单位重量						17.553/2.25 ≈ 7.801kg/m ²

型号 Dwg NO.	GR556601
名称 Profile	边框
壁厚(mm) Thickness	重量(kg/m) Weight
1.2	1.042

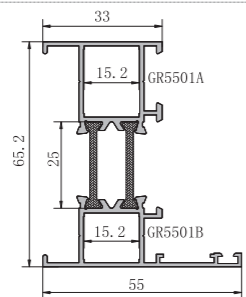

配套角码: GR5507

型号 Dwg NO.	GR556541
名称 Profile	边框
壁厚(mm) Thickness	重量(kg/m) Weight
1.4	1.146

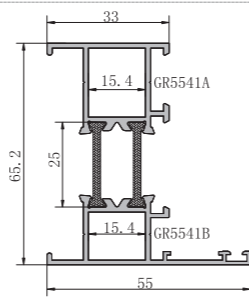

配套角码: JYL6536

型号 Dwg NO.	GR556651
名称 Profile	边框
壁厚(mm) Thickness	重量(kg/m) Weight
1.4	1.28

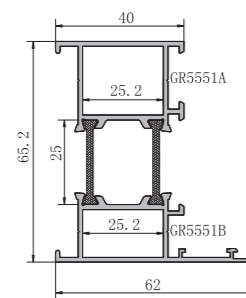

配套角码: JYL65M06

型号 Dwg NO.	GR556641D
名称 Profile	边框
壁厚(mm) Thickness	重量(kg/m) Weight
1.4	1.2

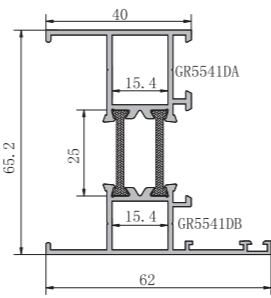

配套角码: JYL6536

型号 Dwg NO.	GR556611
名称 Profile	边框
壁厚(mm) Thickness	重量(kg/m) Weight
1.4	1.108

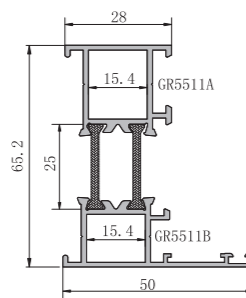

配套角码: JYL6536

型号 Dwg NO.	GR5566101
名称 Profile	边框
壁厚(mm) Thickness	重量(kg/m) Weight
1.3	1.234

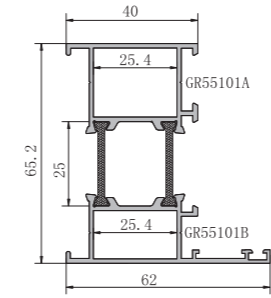

配套角码: HY6011

型号 Dwg NO.	GR556641DC
名称 Profile	边框
壁厚(mm) Thickness	重量(kg/m) Weight
1.4	1.215

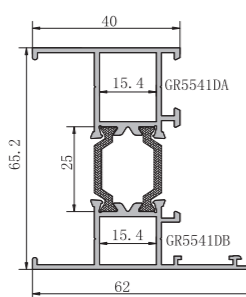

配套角码: JYL6536

型号 Dwg NO.	GR556661
名称 Profile	边框
壁厚(mm) Thickness	重量(kg/m) Weight
1.3	1.072

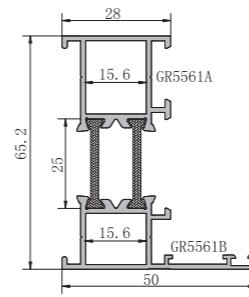

配套角码: ZY11010

型号 Dwg NO.	GR556621
名称 Profile	边框
壁厚(mm) Thickness	重量(kg/m) Weight
1.4	1.109

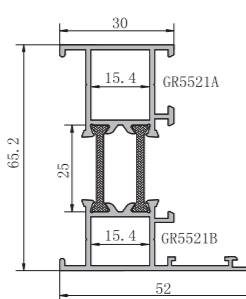

配套角码: JYL6536

型号 Dwg NO.	GR556512
名称 Profile	中梃
壁厚(mm) Thickness	重量(kg/m) Weight
1.4	1.302

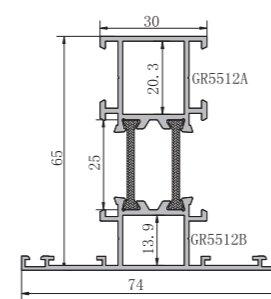

配套角码: GR5508 GR5518

型号 Dwg NO.	GR556682
名称 Profile	中梃
壁厚(mm) Thickness	重量(kg/m) Weight
1.2	1.201

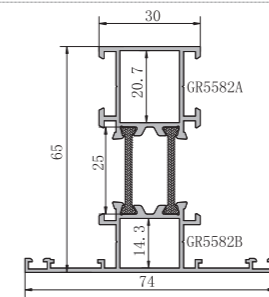

配套角码: GR5508 GR5518

型号 Dwg NO.	GR556642C-ZH
名称 Profile	螺接中梃
壁厚(mm) Thickness	重量(kg/m) Weight
1.4	1.373

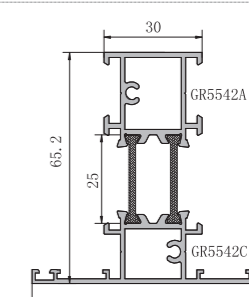

型号 Dwg NO.	GR556672
名称 Profile	螺接中梃
壁厚(mm) Thickness	重量(kg/m) Weight
1.2	1.483

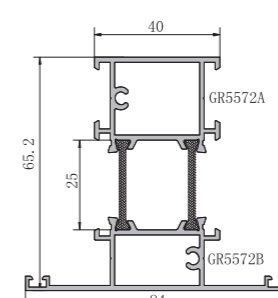

型号 Dwg NO.	GR556602
名称 Profile	螺接中梃
壁厚(mm) Thickness	重量(kg/m) Weight
1.2	1.233

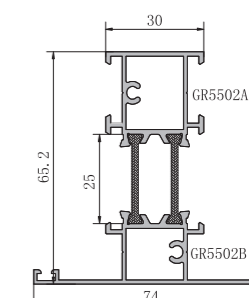

型号 Dwg NO.	GR556542
名称 Profile	螺接中梃
壁厚(mm) Thickness	重量(kg/m) Weight
1.4	1.348

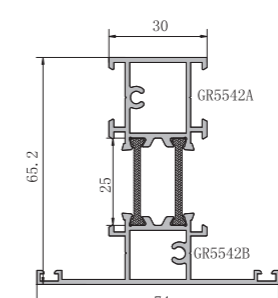

型号 Dwg NO.	GR556622
名称 Profile	中梃
壁厚(mm) Thickness	重量(kg/m) Weight
1.4	1.21

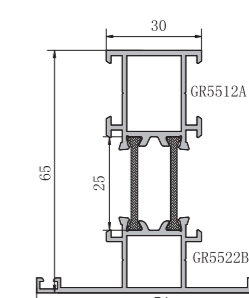

型号 Dwg NO.	GR556642C
名称 Profile	螺接中梃
壁厚(mm) Thickness	重量(kg/m) Weight
1.4	1.363

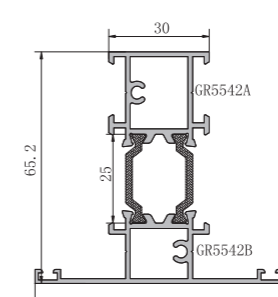

型号 Dwg NO.	GR556602C-ZH
名称 Profile	螺接中梃
壁厚(mm) Thickness	重量(kg/m) Weight
1.2	1.257

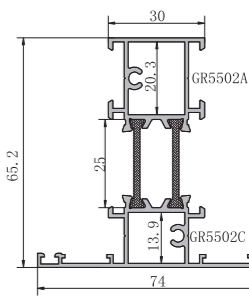

配套角码: GR5508 GR5518

型号 Dwg NO.	GR5566112
名称 Profile	中梃
壁厚(mm) Thickness	重量(kg/m) Weight
1.3	1.243

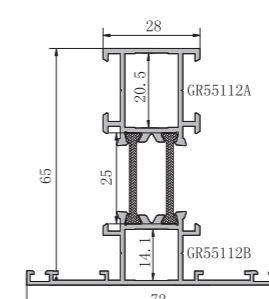

型号 Dwg NO.	GR556504
名称 Profile	转接料
壁厚(mm) Thickness	重量(kg/m) Weight
1.4	1.068

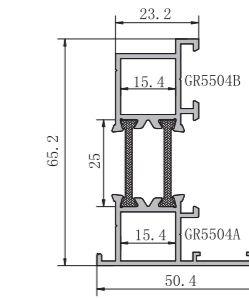

配套角码: JYL6536

型号 Dwg NO.	GR556692D
名称 Profile	螺接中挺
壁厚(mm) Thickness	重量(kg/m) Weight
1.4	2.083

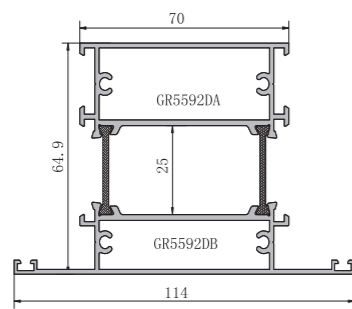

型号 Dwg NO.	GR556693
名称 Profile	内开扇
壁厚(mm) Thickness	重量(kg/m) Weight
1.4	1.362

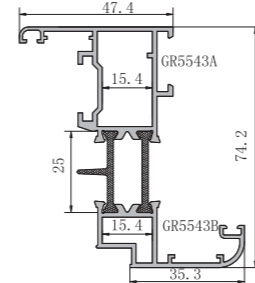

配套角码: JLL6536

型号 Dwg NO.	GR5566103
名称 Profile	内开扇
壁厚(mm) Thickness	重量(kg/m) Weight
1.3	1.307

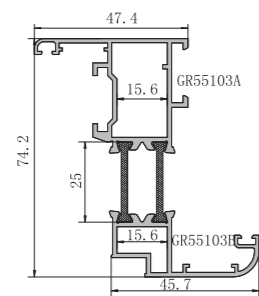

配套角码: ZY11010

型号 Dwg NO.	GR556603
名称 Profile	内开扇
壁厚(mm) Thickness	重量(kg/m) Weight
1.2	1.227

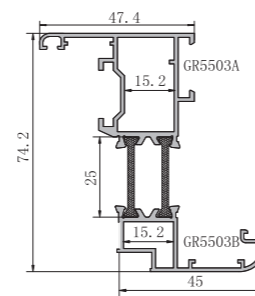

配套角码: GR5507

型号 Dwg NO.	GR5566113
名称 Profile	内开扇
壁厚(mm) Thickness	重量(kg/m) Weight
1.4	1.241

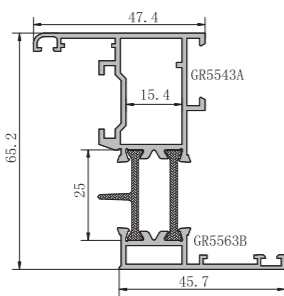

配套角码: JLL6536

型号 Dwg NO.	GR556653
名称 Profile	内开扇
壁厚(mm) Thickness	重量(kg/m) Weight
1.4	1.226

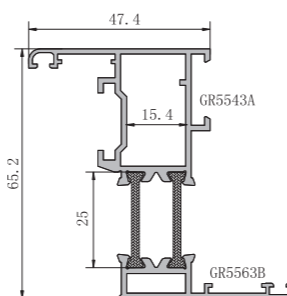

配套角码: JLL6536

型号 Dwg NO.	GR556603T
名称 Profile	内开扇
壁厚(mm) Thickness	重量(kg/m) Weight
1.2	1.243

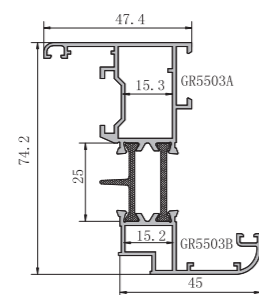

配套角码: GR5507

型号 Dwg NO.	GR556633
名称 Profile	内开扇
壁厚(mm) Thickness	重量(kg/m) Weight
1.4	1.367

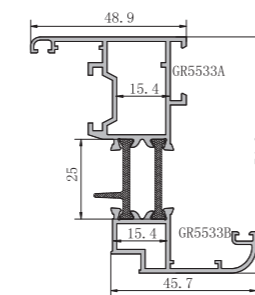

配套角码: JLL6536

型号 Dwg NO.	GR556643C
名称 Profile	内开扇
壁厚(mm) Thickness	重量(kg/m) Weight
1.4	1.363

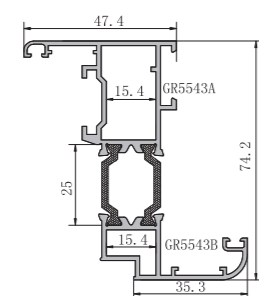

配套角码: JLL6536

型号 Dwg NO.	GR5566543
名称 Profile	内开扇
壁厚(mm) Thickness	重量(kg/m) Weight
1.4	1.348

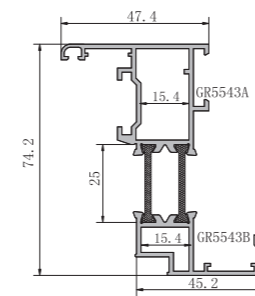

配套角码: JLL6536

型号 Dwg NO.	GR5566123
名称 Profile	内开扇
壁厚(mm) Thickness	重量(kg/m) Weight
1.4	1.592

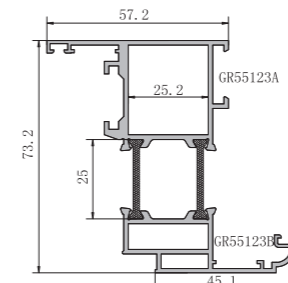

配套角码: JLL65M06

型号 Dwg NO.	GR556673
名称 Profile	外开扇
壁厚(mm) Thickness	重量(kg/m) Weight
1.4	1.421

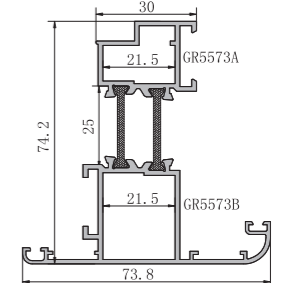

配套角码: GR5527

型号 Dwg NO.	GR5566553
名称 Profile	外开扇
壁厚(mm) Thickness	重量(kg/m) Weight
1.4	1.512

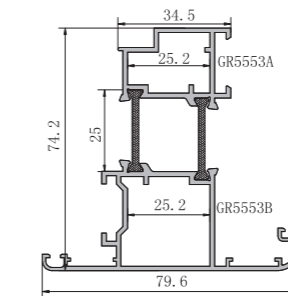

配套角码: JLL65M06

型号 Dwg NO.	GR556662
名称 Profile	加强中挺
壁厚(mm) Thickness	重量(kg/m) Weight
1.4	1.676

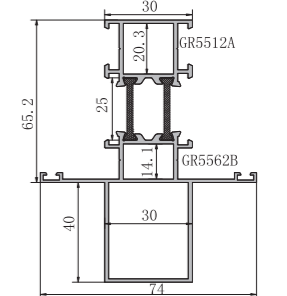

配套角码: GR5508 GR5518

型号 Dwg NO.	GR5566102
名称 Profile	加强螺接中挺
壁厚(mm) Thickness	重量(kg/m) Weight
1.4	2.276

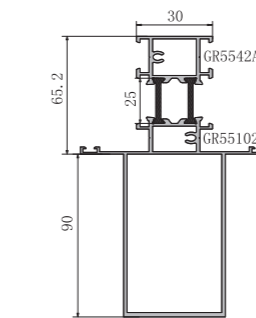

型号 Dwg NO.	GR556652D-ZH
名称 Profile	加强螺接中挺
壁厚(mm) Thickness	重量(kg/m) Weight
1.4	1.932

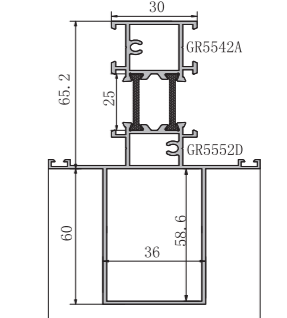

型号 Dwg NO.	GR556652
名称 Profile	加强螺接中挺
壁厚(mm) Thickness	重量(kg/m) Weight
1.4	1.756

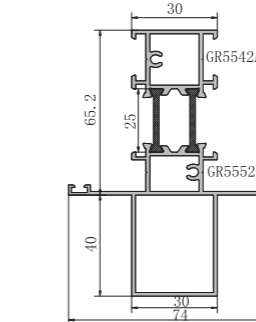

型号 Dwg NO.	GR556519
名称 Profile	拼管
壁厚(mm) Thickness	重量(kg/m) Weight
1.4	0.902

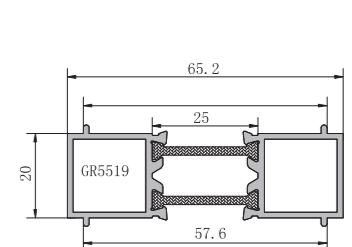

型号 Dwg NO.	GR556659
名称 Profile	拼管
壁厚(mm) Thickness	重量(kg/m) Weight
1.4	0.909

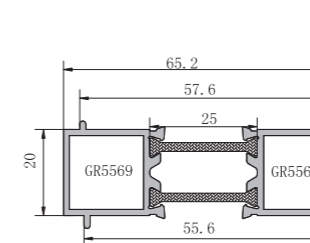

型号 Dwg NO.	GR5566A18
名称 Profile	拼管
壁厚(mm) Thickness	重量(kg/m) Weight
1.4	0.856

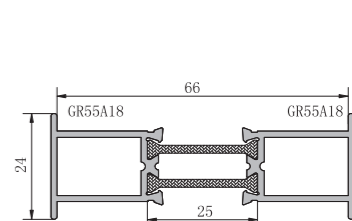

型号 Dwg NO.	GR5566122
名称 Profile	加强焊接中梃
壁厚(mm) Thickness	重量(kg/m) Weight
1.4	2.391

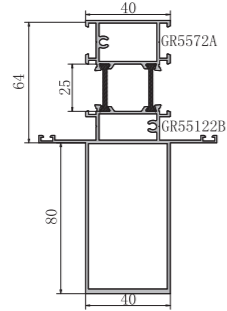

型号 Dwg NO.	GR556692B-ZH
名称 Profile	加强中梃
壁厚(mm) Thickness	重量(kg/m) Weight
1.5	2.410

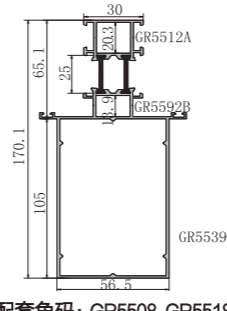

配套角码: GR5508 GR5518

型号 Dwg NO.	GR556652C-ZH
名称 Profile	加强焊接中梃
壁厚(mm) Thickness	重量(kg/m) Weight
1.4	1.786

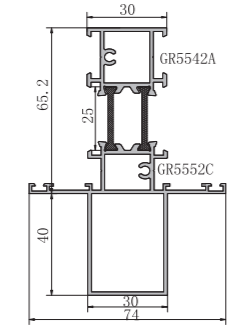

型号 Dwg NO.	GR665539
名称 Profile	拼管
壁厚(mm) Thickness	重量(kg/m) Weight
1.4	1.439

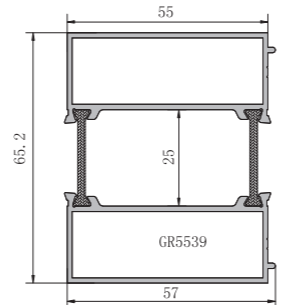

型号 Dwg NO.	LH65135B-ZH
名称 Profile	135° 转角
壁厚(mm) Thickness	重量(kg/m) Weight
1.75	1.426

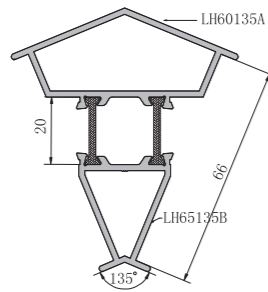

型号 Dwg NO.	GR65F90
名称 Profile	90° 转角
壁厚(mm) Thickness	重量(kg/m) Weight
1.4	1.5

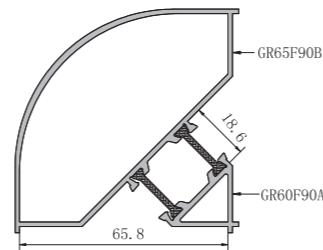

型号 Dwg NO.	GR5528
名称 Profile	中梃连接件
壁厚(mm) Thickness	重量(kg/m) Weight
2.5	0.479

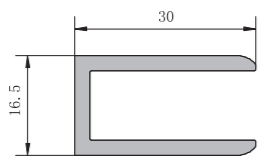

型号 Dwg NO.	GRSC02
名称 Profile	纱料
壁厚(mm) Thickness	重量(kg/m) Weight
1.2	0.316

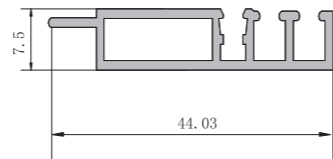

型号 Dwg NO.	GR5529
名称 Profile	拼条
壁厚(mm) Thickness	重量(kg/m) Weight
1.4	0.097

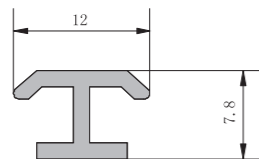

型号 Dwg NO.	XI-ST
名称 Profile	锁条
壁厚(mm) Thickness	重量(kg/m) Weight
1.5	0.105

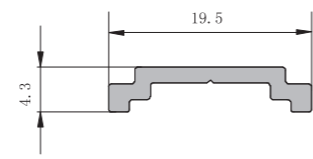

型号 Dwg NO.	GR5508
名称 Profile	中梃插件
壁厚(mm) Thickness	重量(kg/m) Weight
3.0	1.134

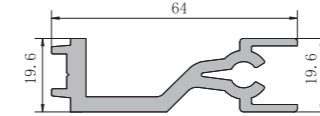

型号 Dwg NO.	GR5518
名称 Profile	中梃插件
壁厚(mm) Thickness	重量(kg/m) Weight
2.5	0.794

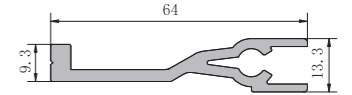

型号 Dwg NO.	GR5588
名称 Profile	中梃连接件
壁厚(mm) Thickness	重量(kg/m) Weight
2.5	0.55

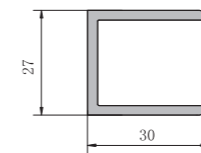

型号 Dwg NO.	GR55YZ
名称 Profile	压座
壁厚(mm) Thickness	重量(kg/m) Weight
1.5	0.164

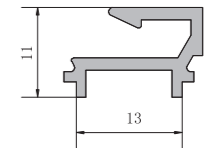

型号 Dwg NO.	GR5507
名称 Profile	角码
壁厚(mm) Thickness	重量(kg/m) Weight
3.0	1.794

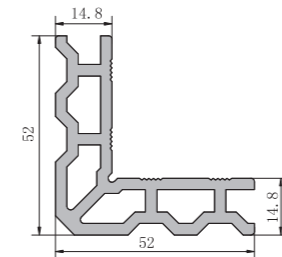

型号 Dwg NO.	GR5507A
名称 Profile	角码
壁厚(mm) Thickness	重量(kg/m) Weight
3.0	1.847

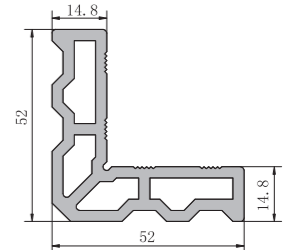

型号 Dwg NO.	GR5517
名称 Profile	角码
壁厚(mm) Thickness	重量(kg/m) Weight
3.0	2.328

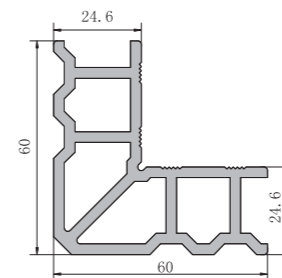

型号 Dwg NO.	GR5527
名称 Profile	角码
壁厚(mm) Thickness	重量(kg/m) Weight
2.8	1.899

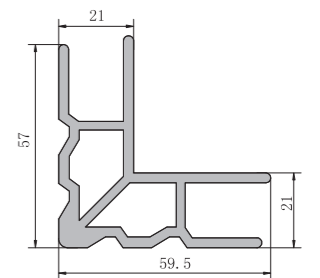

型号 Dwg NO.	GR55336
名称 Profile	压线
壁厚(mm) Thickness	重量(kg/m) Weight
1.0	0.211

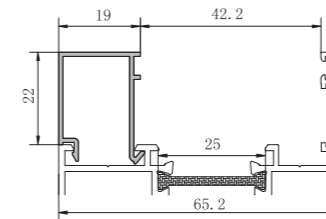

型号 Dwg NO.	XT56216
名称 Profile	压线
壁厚(mm) Thickness	重量(kg/m) Weight
1.0	0.214

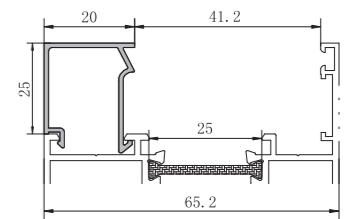

型号 Dwg NO.	GR55116
名称 Profile	压线
壁厚(mm) Thickness	重量(kg/m) Weight
1.0	0.191

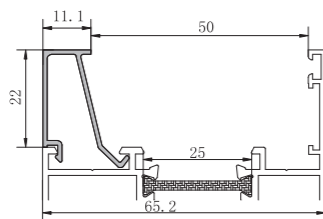

型号 Dwg NO.	GR5586
名称 Profile	压线
壁厚(mm) Thickness	重量(kg/m) Weight
1.0	0.227

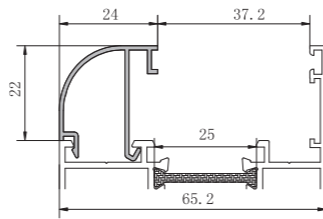

型号 Dwg NO.	GR5537
名称 Profile	压线
壁厚(mm) Thickness	重量(kg/m) Weight
1.0	0.215

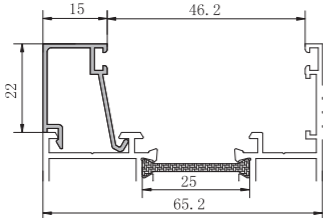

型号 Dwg NO.	GR5586A
名称 Profile	压线
壁厚(mm) Thickness	重量(kg/m) Weight
1.0	0.171

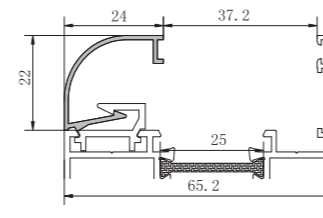

型号 Dwg NO.	GR5576
名称 Profile	压线
壁厚(mm) Thickness	重量(kg/m) Weight
1.0	0.223

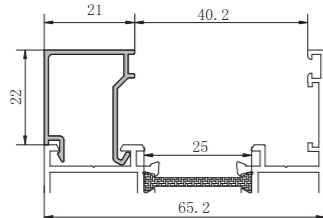

型号 Dwg NO.	GR5506
名称 Profile	压线
壁厚(mm) Thickness	重量(kg/m) Weight
1.0	0.243

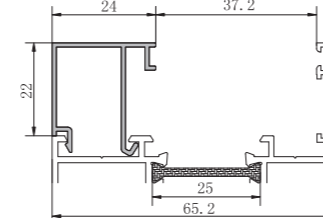

型号 Dwg NO.	GR5516
名称 Profile	压线
壁厚(mm) Thickness	重量(kg/m) Weight
1.0	0.244

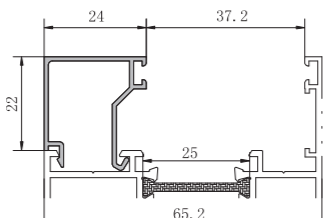

型号 Dwg NO.	XT5526
名称 Profile	压线
壁厚(mm) Thickness	重量(kg/m) Weight
1.0	0.243

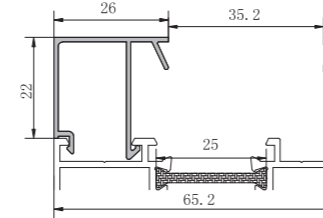

型号 Dwg NO.	GR55126
名称 Profile	压线
壁厚(mm) Thickness	重量(kg/m) Weight
1.0	0.244

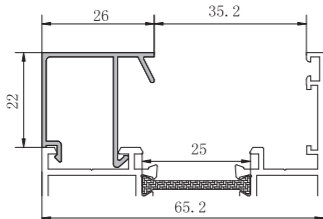

型号 Dwg NO.	GR5506A
名称 Profile	压线
壁厚(mm) Thickness	重量(kg/m) Weight
1.0	0.251

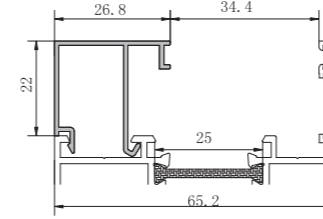

型号 Dwg NO.	GR5546
名称 Profile	压线
壁厚(mm) Thickness	重量(kg/m) Weight
1.0	0.257

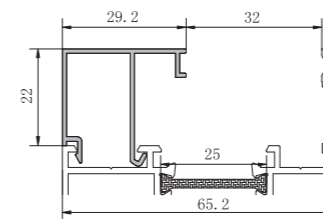

型号 Dwg NO.	GR5546A
名称 Profile	压线
壁厚(mm) Thickness	重量(kg/m) Weight
1.0	0.262

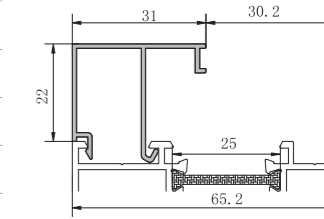

型号 Dwg NO.	GR5585
名称 Profile	压线
壁厚(mm) Thickness	重量(kg/m) Weight
0.7	0.184

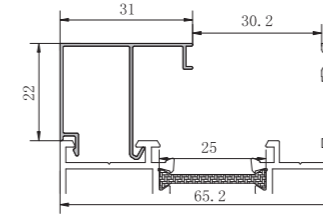

型号 Dwg NO.	GR100T5
名称 Profile	压线
壁厚(mm) Thickness	重量(kg/m) Weight
1.2	0.308

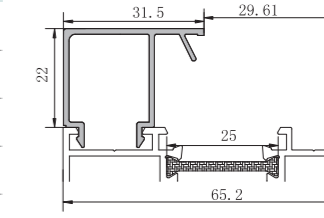

型号 Dwg NO.	PY6016
名称 Profile	压线
壁厚(mm) Thickness	重量(kg/m) Weight
1.0	0.269

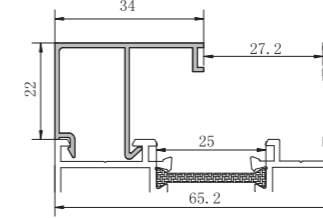

型号 Dwg NO.	GR5596A
名称 Profile	压线
壁厚(mm) Thickness	重量(kg/m) Weight
1.0	0.31

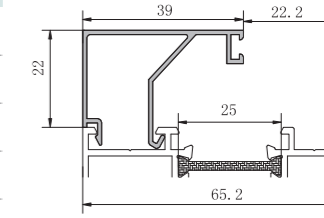

型号 Dwg NO.	GR5526
名称 Profile	压线
壁厚(mm) Thickness	重量(kg/m) Weight
1.0	0.196

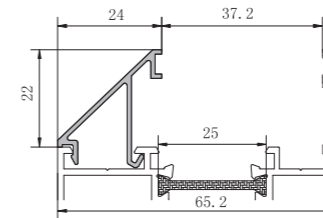

型号 Dwg NO.	GR5556
名称 Profile	压线
壁厚(mm) Thickness	重量(kg/m) Weight
1.0	0.199

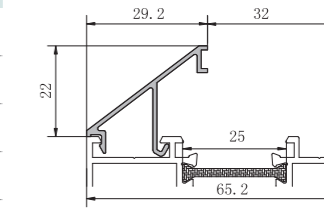

型号 Dwg NO.	GR55326
名称 Profile	压线
壁厚(mm) Thickness	重量(kg/m) Weight
1.0	0.194

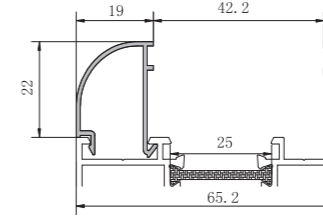

型号 Dwg NO.	GR55326A
名称 Profile	压线
壁厚(mm) Thickness	重量(kg/m) Weight
1.0	0.158

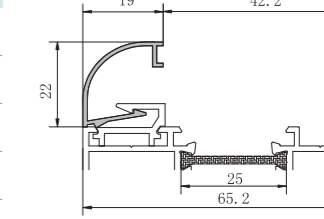

型号 Dwg NO.	GR5566
名称 Profile	压线
壁厚(mm) Thickness	重量(kg/m) Weight
1.0	0.204

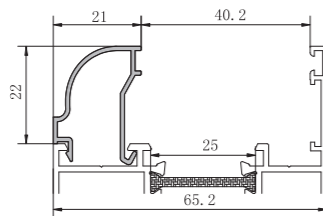

型号 Dwg NO.	GR5586B
名称 Profile	压线
壁厚(mm) Thickness	重量(kg/m) Weight
1.0	0.222

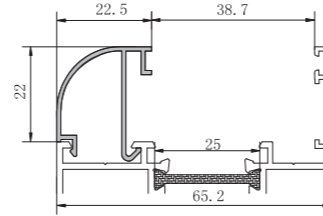

型号 Dwg NO.	
名称 Profile	
壁厚(mm) Thickness	重量(kg/m) Weight

型号 Dwg NO.	
名称 Profile	
壁厚(mm) Thickness	重量(kg/m) Weight

型号 Dwg NO.	
名称 Profile	
壁厚(mm) Thickness	重量(kg/m) Weight

型号 Dwg NO.	
名称 Profile	
壁厚(mm) Thickness	重量(kg/m) Weight

型号 Dwg NO.	
名称 Profile	
壁厚(mm) Thickness	重量(kg/m) Weight

型号 Dwg NO.	
名称 Profile	
壁厚(mm) Thickness	重量(kg/m) Weight

型号 Dwg NO.	
名称 Profile	
壁厚(mm) Thickness	重量(kg/m) Weight

型号 Dwg NO.	
名称 Profile	
壁厚(mm) Thickness	重量(kg/m) Weight

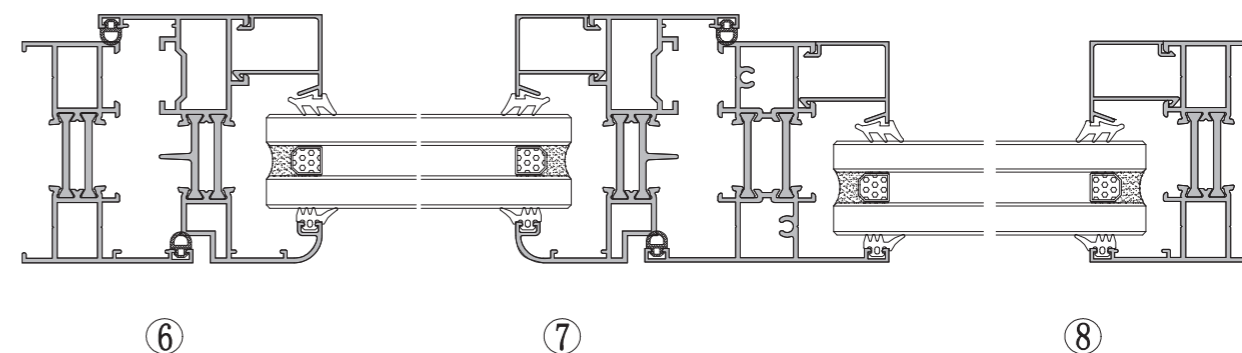
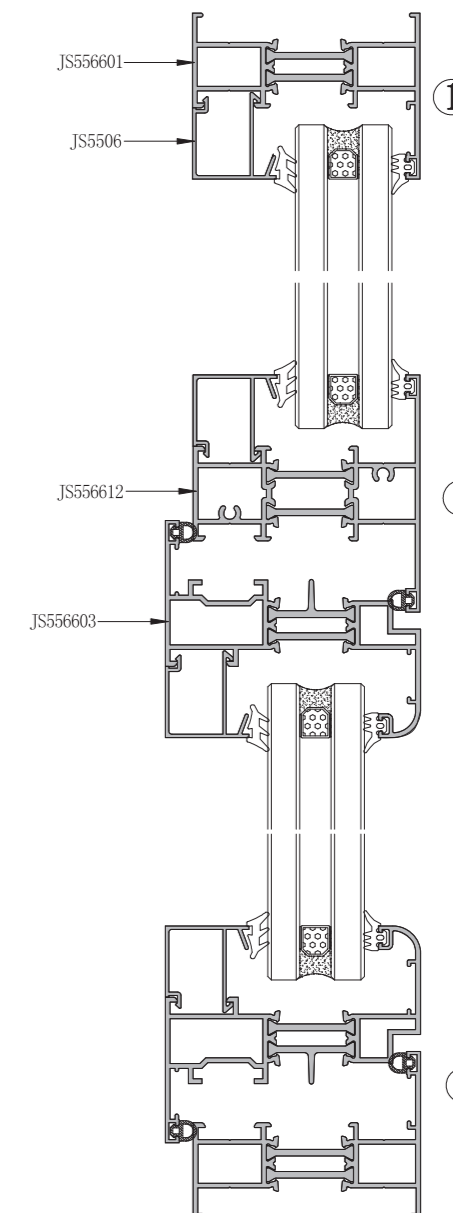
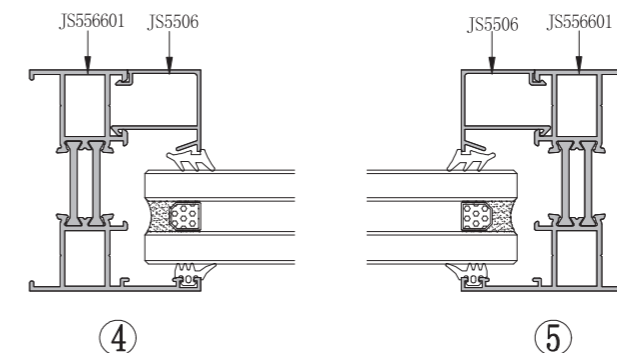
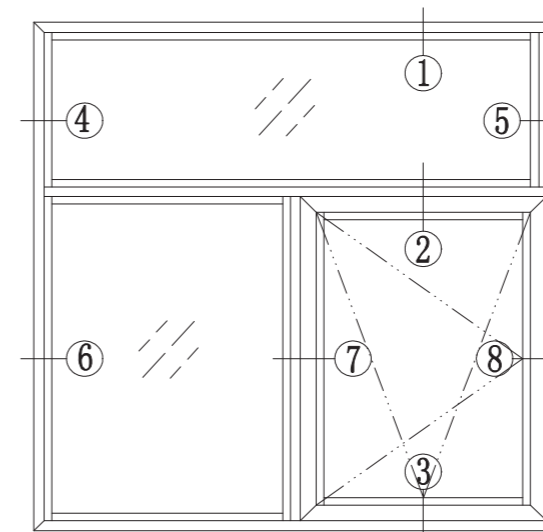

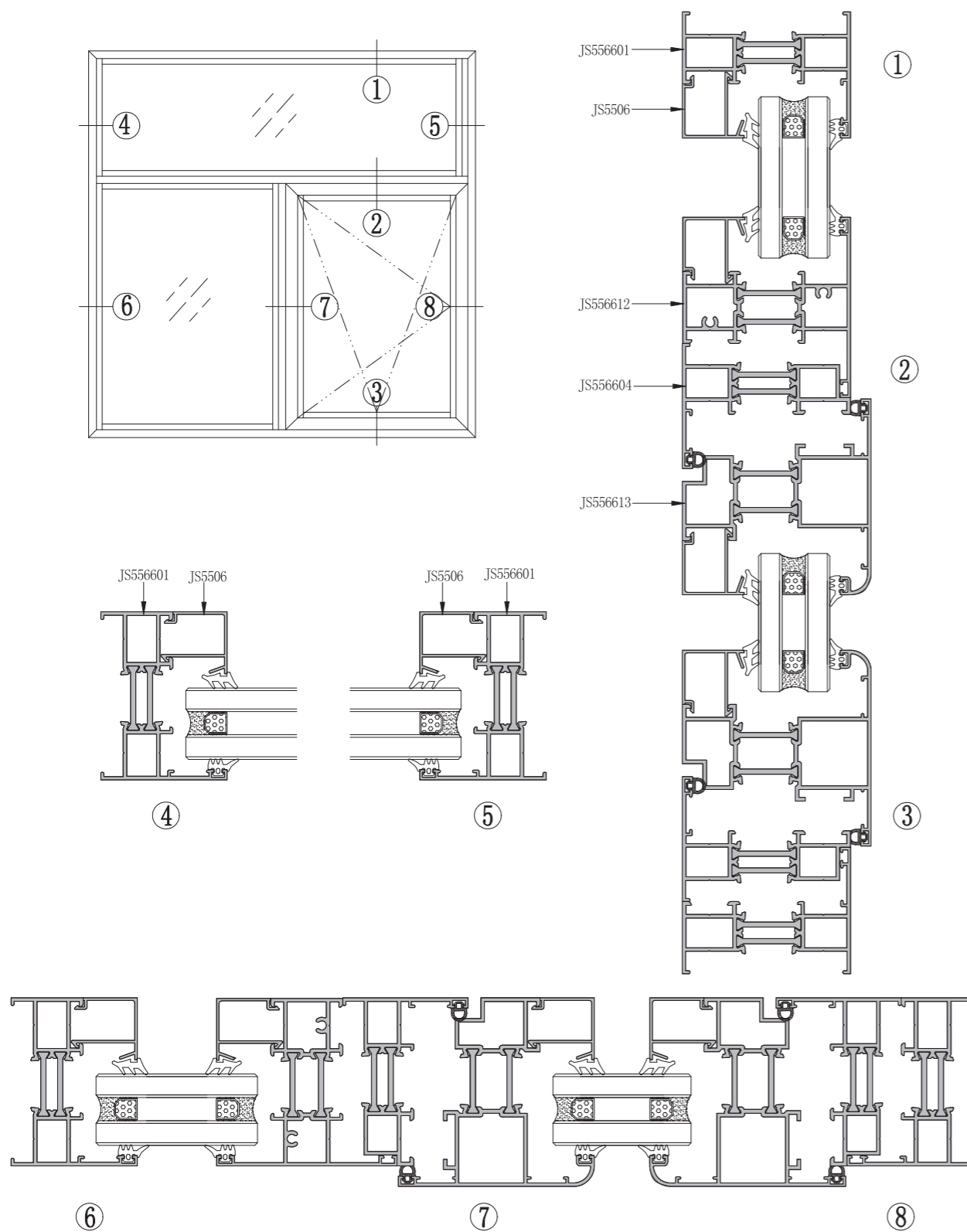

更换14.8隔热条为55系列

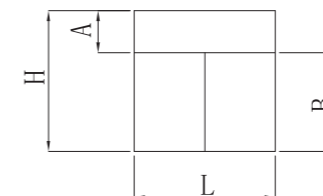

H=1500mm
L=1500mm
A=500mm
B=1000mm

用料清单 (仅供参考)

名称	型号	公式	长度 (mm)	每米重量	数量	重量(kg)
横边框	JS5501	L	1500	0.963	2	2.889
竖边框	JS5501	H	1500	0.963	2	2.889
横中梃	JS5512	L-46	1454	1.188	1	1.727
竖中梃	JS5512	B-32	968	1.188	1	1.150
上固窗横压线	JS5506	L-56	1444	0.231	2	0.667
上固窗竖压线	JS5506	A-84	416	0.231	2	0.192
侧固窗横压线	JS5506	L/2-42	708	0.231	2	0.327
侧固窗竖压线	JS5506	B-84	916	0.231	2	0.423
窗扇横料	JS5503	L/2-30	720	1.161	2	1.672
窗扇竖料	JS5503	B-30	970	1.161	2	2.252
窗扇横压线	JS5506	L/2-116	634	0.231	2	0.293
窗扇竖压线	JS5506	B-158	842	0.231	2	0.389
框角码 (内)	JS5507	17.8	17.8	1.612	4	0.115
框角码 (外)	JS5507	16	16.0	1.612	4	0.103
扇角码 (内)	JS5507	26.2	26.2	1.612	4	0.169
扇角码 (外)	JS5507	7.6	7.6	1.612	4	0.049
合计 (kg)						15.307
铝窗面积		宽1.5米		高1.5米		2.25m ²
单位重量		15.307/2.25≈6.803kg/m ²				

更换20隔热条为60系列

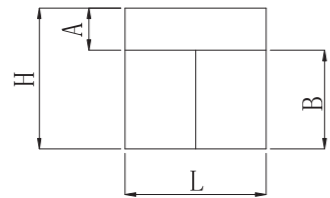

H=1500mm
L=1500mm
A=500mm
B=1000mm

用料清单 (仅供参考)

名称	型号	公式	长度 (mm)	每米重量	数量	重量(kg)
横边框	JS6001	L	1500	0.991	2	2.973
竖边框	JS6001	H	1500	0.991	2	2.973
横中梃	JS6012	L-46	1454	1.216	1	1.768
竖中梃	JS6012	B-32	968	1.216	1	1.177
上固窗横压线	JS5506	L-56	1444	0.231	2	0.667
上固窗竖压线	JS5506	A-84	416	0.231	2	0.192
侧固窗横压线	JS5506	L/2-42	708	0.231	2	0.327
侧固窗竖压线	JS5506	B-84	916	0.231	2	0.423
窗扇横料	JS6043	L/2-30	720	1.192	2	1.716
窗扇竖料	JS6043	B-30	970	1.192	2	2.312
窗扇横压线	JS5506	L/2-116	634	0.231	2	0.293
窗扇竖压线	JS5506	B-158	842	0.231	2	0.389
框角码 (内)	JS5507	17.8	17.8	1.612	4	0.115
框角码 (外)	JS5507	16	16.0	1.612	4	0.103
扇角码 (内)	JS5507	26.2	26.2	1.612	4	0.169
扇角码 (外)	JS5507	7.6	7.6	1.612	4	0.049
合计 (kg)						15.648
铝窗面积	宽1.5米	高1.5米	2.25m ²			
单位重量	15.648/2.25≈6.955kg/m ²					

更换24隔热条为65系列

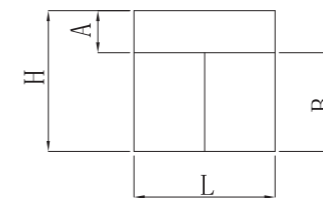

H=1500mm
L=1500mm
A=500mm
B=1000mm

用料清单 (仅供参考)

名称	型号	公式	长度 (mm)	每米重量	数量	重量(kg)
横边框	JS556501	L	1500	1.011	2	3.033
竖边框	JS556501	H	1500	1.011	2	3.033
横中梃	JS556512	L-46	1454	1.251	1	1.819
竖中梃	S556512	B-32	968	1.251	1	1.211
上固窗横压线	JS5506	L-56	1444	0.231	2	0.667
上固窗竖压线	JS5506	A84	416	0.231	2	0.192
侧固窗横压线	JS5506	L/2-42	708	0.231	2	0.327
侧固窗竖压线	JS5506	B-84	916	0.231	2	0.423
窗扇横料	JS556503	L/2-30	720	1.211	2	1.744
窗扇竖料	JS556503	B-30	970	1.211	2	2.349
窗扇横压线	JS5506	L/2-116	634	0.231	2	0.293
窗扇竖压线	JS5506	B-158	842	0.231	2	0.389
框角码 (内)	JS5507	17.8	17.8	1.612	4	0.115
框角码 (外)	JS5507	16	16.0	1.612	4	0.103
扇角码 (内)	JS5507	26.2	26.2	1.612	4	0.169
扇角码 (外)	JS5507	7.6	7.6	1.612	4	0.049
合计 (kg)						15.917
铝窗面积	宽1.5米	高1.5米	2.25m ²			
单位重量	15.917/2.25≈7.074kg/m ²					

更换25隔热条为66系列

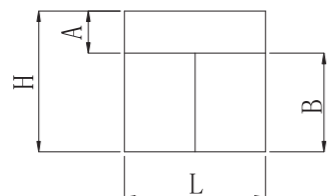

H=1500mm
L=1500mm
A=500mm
B=1000mm

用料清单 (仅供参考)

名称	型号	公式	长度 (mm)	每米重量	数量	重量(kg)
横边框	JS556601	L	1500	1.017	2	3.051
竖边框	JS556601	H	1500	1.017	2	3.051
横中框	JS556612	L-46	1454	1.256	1	1.826
竖中框	JS556612	B-32	968	1.256	1	1.216
上固窗横压线	JS5506	L-56	1444	0.231	2	0.667
上固窗竖压线	JS5506	A-84	416	0.231	2	0.192
侧固窗横压线	JS5506	L/2-42	708	0.231	2	0.327
侧固窗竖压线	JS5506	B-84	916	0.231	2	0.423
窗扇横料	JS556603	L/2-30	720	1.216	2	1.751
窗扇竖料	JS556603	B-30	970	1.216	2	2.359
窗扇横压线	JS5506	L/2-116	634	0.231	2	0.293
窗扇竖压线	JS5506	B-158	842	0.231	2	0.389
框角码 (内)	JS5507	17.8	17.8	1.612	4	0.115
框角码 (外)	JS5507	16	16.0	1.612	4	0.103
扇角码 (内)	JS5507	26.2	26.2	1.612	4	0.169
扇角码 (外)	JS5507	7.6	7.6	1.612	4	0.049
合计 (kg)						15.917
铝窗面积	宽1.5米	高1.5米				2.25m ²
单位重量						15.982/2.25≈7.103kg/m ²

更换30隔热条为70系列

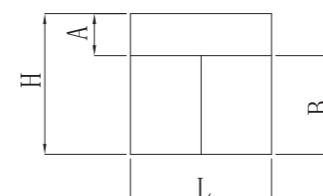

H=1500mm
L=1500mm
A=500mm
B=1000mm

用料清单 (仅供参考)

名称	型号	公式	长度 (mm)	每米重量	数量	重量(kg)
横边框	JS557001	L	1500	1.073	2	3.219
竖边框	JS557001	H	1500	1.073	2	3.219
横中框	JS557012	L-46	1454	1.313	1	1.909
竖中框	JS557012	B-32	968	1.313	1	1.271
上固窗横压线	JS5506	L-56	1444	0.231	2	0.667
上固窗竖压线	JS5506	A-84	416	0.231	2	0.192
侧固窗横压线	JS5506	L/2-42	708	0.231	2	0.327
侧固窗竖压线	JS5506	B-84	916	0.231	2	0.423
窗扇横料	JS557003	L/2-30	720	1.263	2	1.819
窗扇竖料	JS557003	B-30	970	1.263	2	2.450
窗扇横压线	JS5506	L/2-116	634	0.231	2	0.293
窗扇竖压线	JS5506	B-158	842	0.231	2	0.389
框角码 (内)	JS5507	17.8	17.8	1.612	4	0.115
框角码 (外)	JS5507	16	16.0	1.612	4	0.103
扇角码 (内)	JS5507	26.2	26.2	1.612	4	0.169
扇角码 (外)	JS5507	7.6	7.6	1.612	4	0.049
合计 (kg)						16.614
铝窗面积	宽1.5米	高1.5米				2.25m ²
单位重量						16.614/2.25≈7.384kg/m ²

型号 Dwg NO.	JS556601
名称 Profile	窗边框
壁厚(mm) Thickness	重量(kg/m) Weight
1.4	1.017
型号 Dwg NO.	JS556601-1.8
壁厚(mm) Thickness	重量(kg/m) Weight
1.8	1.202

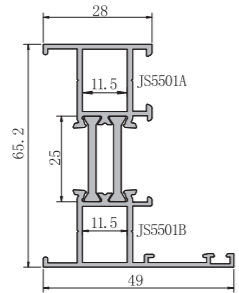

配套角码: JS5507

型号 Dwg NO.	JS556631
名称 Profile	窗边框
壁厚(mm) Thickness	重量(kg/m) Weight
1.4	1.047
型号 Dwg NO.	JS556631-1.8
壁厚(mm) Thickness	重量(kg/m) Weight
1.8	1.257

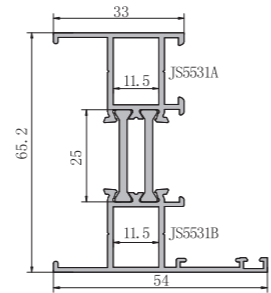

配套角码: JS5507

型号 Dwg NO.	JS556612
名称 Profile	中梃
壁厚(mm) Thickness	重量(kg/m) Weight
1.4	1.256
型号 Dwg NO.	JS556612-1.8
壁厚(mm) Thickness	重量(kg/m) Weight
1.8	1.451

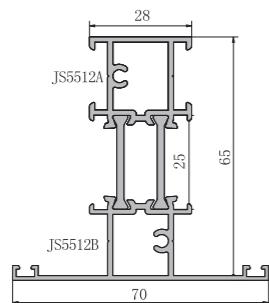

型号 Dwg NO.	JS556602
名称 Profile	中梃
壁厚(mm) Thickness	重量(kg/m) Weight
1.4	1.189
型号 Dwg NO.	JS556602-1.8
壁厚(mm) Thickness	重量(kg/m) Weight
1.8	1.374

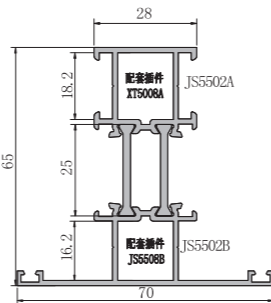

型号 Dwg NO.	JS556652
名称 Profile	加强中梃
壁厚(mm) Thickness	重量(kg/m) Weight
1.4	1.325

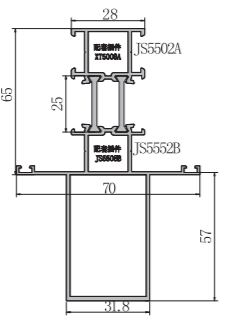

型号 Dwg NO.	JS556642
名称 Profile	加强中梃
壁厚(mm) Thickness	重量(kg/m) Weight
1.4	1.877

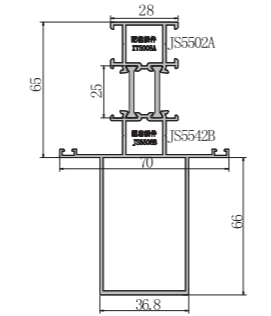

型号 Dwg NO.	JS556632
名称 Profile	加强螺栓中梃
壁厚(mm) Thickness	重量(kg/m) Weight
1.4	1.71

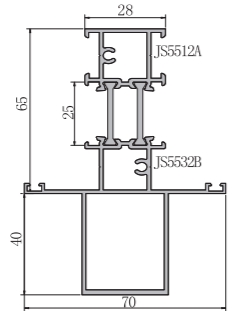

型号 Dwg NO.	TS556632X
名称 Profile	加强螺栓中梃
壁厚(mm) Thickness	重量(kg/m) Weight
1.4	1.532

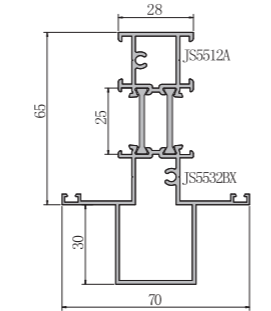

型号 Dwg NO.	JS556632
名称 Profile	加强螺栓中梃
壁厚(mm) Thickness	重量(kg/m) Weight
1.4	1.71

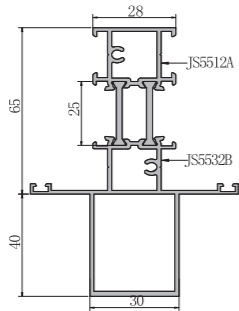

型号 Dwg NO.	JS556643
名称 Profile	内开窗扇
壁厚(mm) Thickness	重量(kg/m) Weight
1.4	1.199

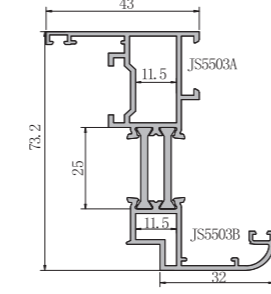

配套角码: JS5507

型号 Dwg NO.	JS556663
名称 Profile	内开窗扇
壁厚(mm) Thickness	重量(kg/m) Weight
1.4	1.118

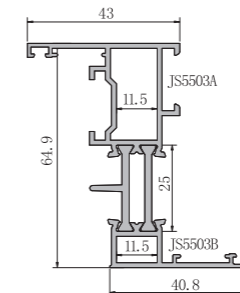

配套角码: JS5507

型号 Dwg NO.	JS556603
名称 Profile	内开窗扇
壁厚(mm) Thickness	重量(kg/m) Weight
1.4	1.216

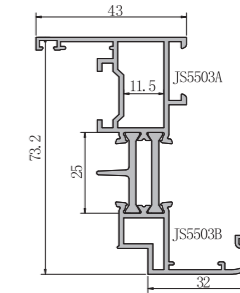

配套角码: JS5507

型号 Dwg NO.	JS556623
名称 Profile	内开扇
壁厚(mm) Thickness	重量(kg/m) Weight
1.4	1.346

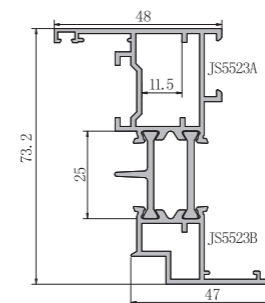

型号 Dwg NO.	JS556633
名称 Profile	外开扇
壁厚(mm) Thickness	重量(kg/m) Weight
1.4	1.723

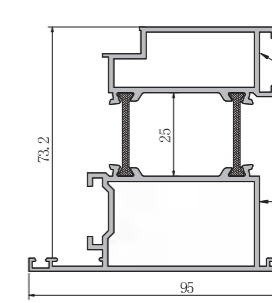

型号 Dwg NO.	JS556653
名称 Profile	内开扇
壁厚(mm) Thickness	重量(kg/m) Weight
1.4	1.203
型号 Dwg NO.	JS556653-1.8
壁厚(mm) Thickness	重量(kg/m) Weight
1.8	1.475

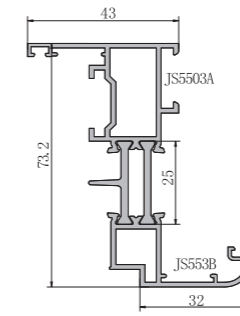

型号 Dwg NO.	JS556613
名称 Profile	外开扇
壁厚(mm) Thickness	重量(kg/m) Weight
1.4	1.41
型号 Dwg NO.	JS556613-1.8
壁厚(mm) Thickness	重量(kg/m) Weight
1.8	1.691

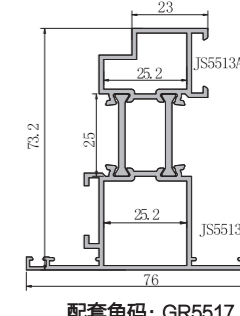

配套角码: GR5517

型号 Dwg NO.	JS556604
名称 Profile	转换料
壁厚(mm) Thickness	重量(kg/m) Weight
1.4	0.964
型号 Dwg NO.	JS556604-1.8
壁厚(mm) Thickness	重量(kg/m) Weight
1.8	1.137

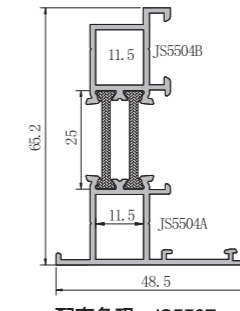

配套角码: JS5507

型号 Dwg NO.	JS556611
名称 Profile	窗边框
壁厚(mm) Thickness	重量(kg/m) Weight
1.5	1.306

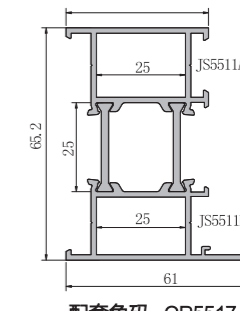

配套角码: GR5517

型号 Dwg NO.	JS556621
名称 Profile	窗边框
壁厚(mm) Thickness	重量(kg/m) Weight
1.4	1.037

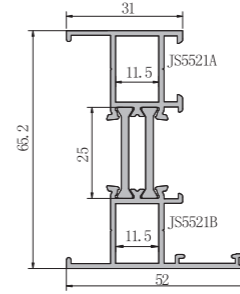

配套角码: JS5507

型号 Dwg NO.	ZL6505
名称 Profile	90° 转角
壁厚(mm) Thickness	重量(kg/m) Weight
1.4	1.483

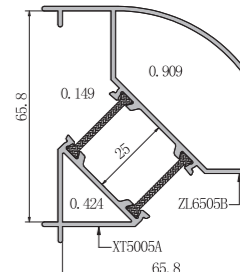

型号 Dwg NO.	JS5507
名称 Profile	角码
壁厚(mm) Thickness	重量(kg/m) Weight
2.5	1.612

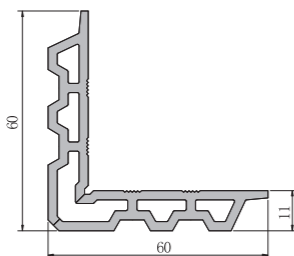

型号 Dwg NO.	GR5517
名称 Profile	角码
壁厚(mm) Thickness	重量(kg/m) Weight
3.0	2.328

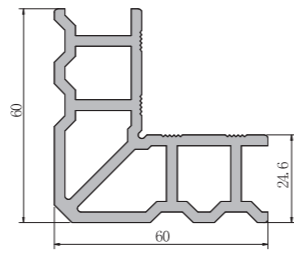

型号 Dwg NO.	XT5008A
名称 Profile	中挺插件
壁厚(mm) Thickness	重量(kg/m) Weight
3.0	1.104

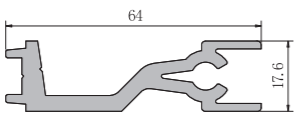

型号 Dwg NO.	JS5508B
名称 Profile	中挺插件
壁厚(mm) Thickness	重量(kg/m) Weight
2.5	0.899

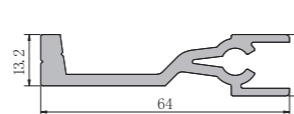

型号 Dwg NO.	6810H-20
名称 Profile	拼管
壁厚(mm) Thickness	重量(kg/m) Weight
1.4	0.966

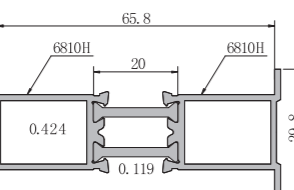

型号 Dwg NO.	JS5535
名称 Profile	万能转角组件
壁厚(mm) Thickness	重量(kg/m) Weight
1.5	0.159

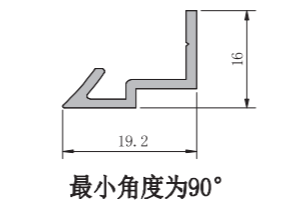

型号 Dwg NO.	LH65135B-ZH
名称 Profile	135° 转角
壁厚(mm) Thickness	重量(kg/m) Weight
1.75	1.423

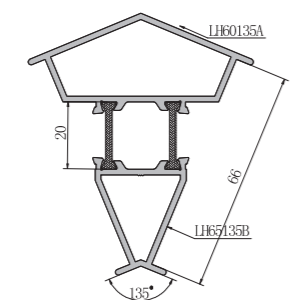

型号 Dwg NO.	XT6025
名称 Profile	万能转角
壁厚(mm) Thickness	重量(kg/m) Weight
1.4	1.643

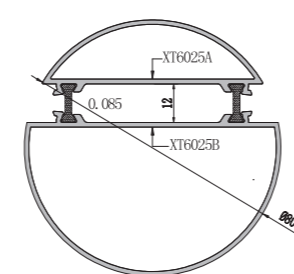

型号 Dwg NO.	XT-SC
名称 Profile	纱窗
壁厚(mm) Thickness	重量(kg/m) Weight
1.0	0.267

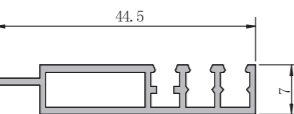

型号 Dwg NO.	XT-ST
名称 Profile	锁条
壁厚(mm) Thickness	重量(kg/m) Weight
1.5	0.106

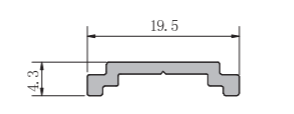

型号 Dwg NO.	JS5514
名称 Profile	拼条
壁厚(mm) Thickness	重量(kg/m) Weight
1.4	0.19

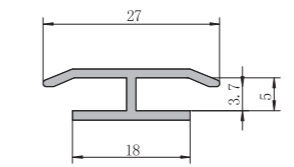

型号 Dwg NO.	JS5546
名称 Profile	压线
壁厚(mm) Thickness	重量(kg/m) Weight
0.8	0.185

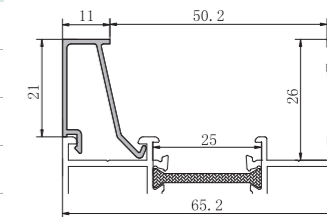

型号 Dwg NO.	JS5566
名称 Profile	压线
壁厚(mm) Thickness	重量(kg/m) Weight
1.0	0.202

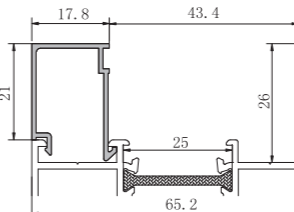

型号 Dwg NO.	JS5536
名称 Profile	压线
壁厚(mm) Thickness	重量(kg/m) Weight
1.0	0.224

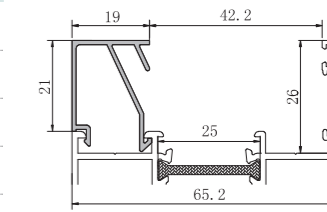

型号 Dwg NO.	JS55M06
名称 Profile	压线
壁厚(mm) Thickness	重量(kg/m) Weight
1.0	0.234

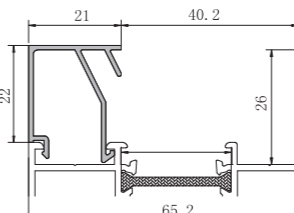

型号 Dwg NO.	JS5506
名称 Profile	压线
壁厚(mm) Thickness	重量(kg/m) Weight
1.0	0.231

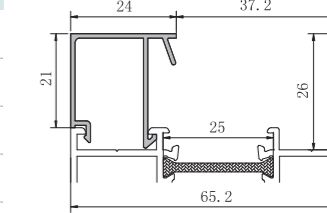

型号 Dwg NO.	JS5516
名称 Profile	压线
壁厚(mm) Thickness	重量(kg/m) Weight
1.0	0.24

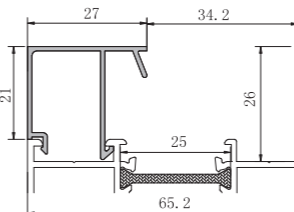

型号 Dwg NO.	XT6006
名称 Profile	压线
壁厚(mm) Thickness	重量(kg/m) Weight
1.0	0.25

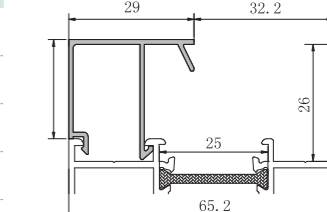

型号 Dwg NO.	JSYX-F18
名称 Profile	压线
壁厚(mm) Thickness	重量(kg/m) Weight
1.0	0.194

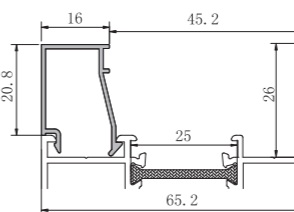

型号 Dwg NO.	JSYX-Y18
名称 Profile	压线
壁厚(mm) Thickness	重量(kg/m) Weight
1.0	0.182

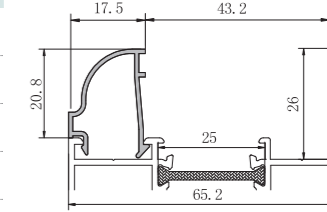

型号 Dwg NO.	ZL6506
名称 Profile	压线
壁厚(mm) Thickness	重量(kg/m) Weight
1.0	0.263

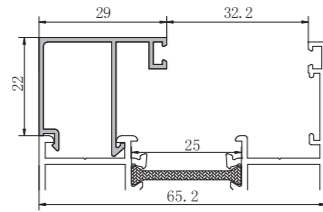

型号 Dwg NO.	JS5576
名称 Profile	压线
壁厚(mm) Thickness	重量(kg/m) Weight
0.8	0.212

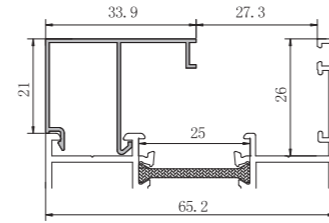

型号 Dwg NO.	JS5586
名称 Profile	压线
壁厚(mm) Thickness	重量(kg/m) Weight
1.0	0.176

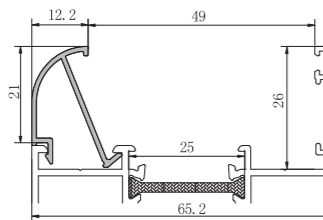

型号 Dwg NO.	JS5556
名称 Profile	压线
壁厚(mm) Thickness	重量(kg/m) Weight
0.9	0.185

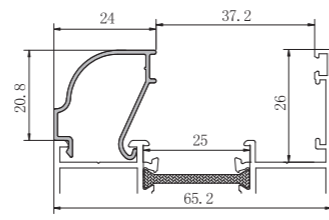

型号 Dwg NO.	JS5526
名称 Profile	压线
壁厚(mm) Thickness	重量(kg/m) Weight
1.0	0.188

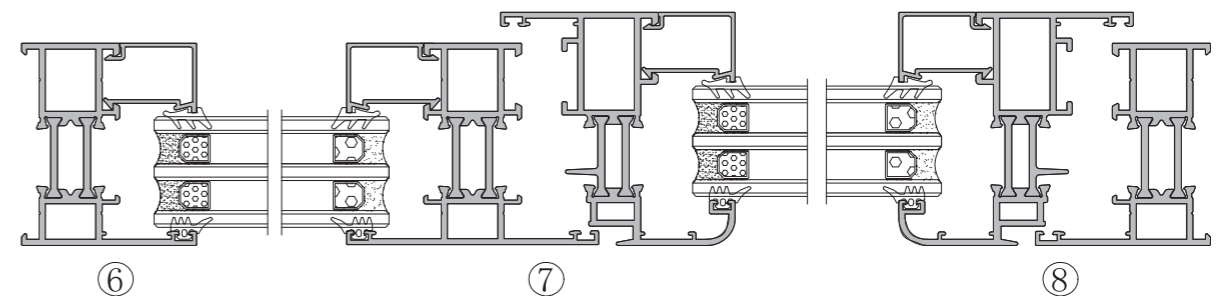
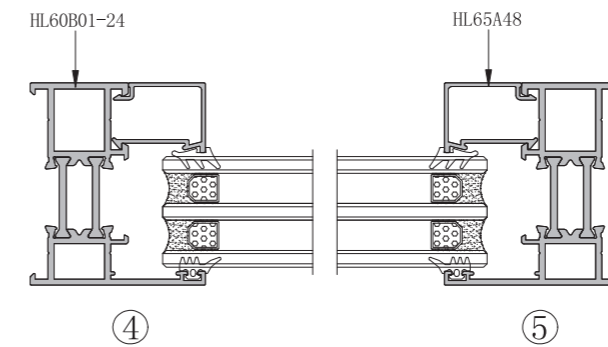
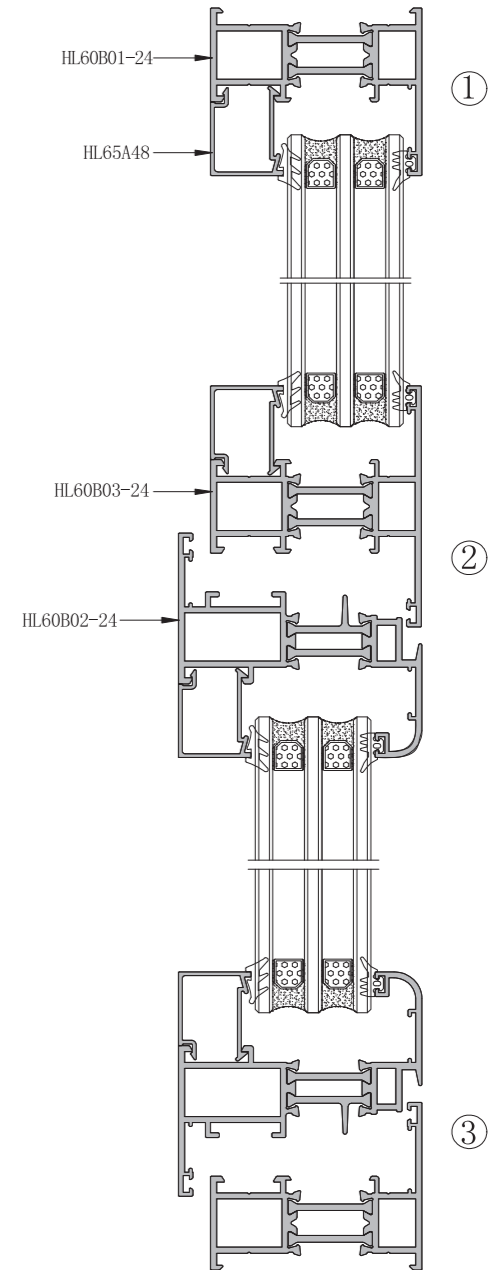
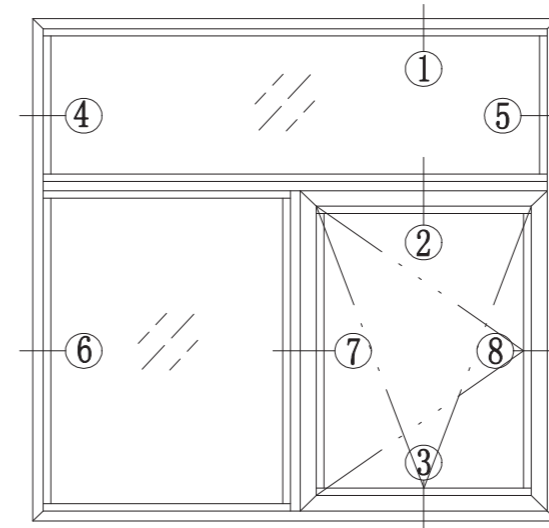
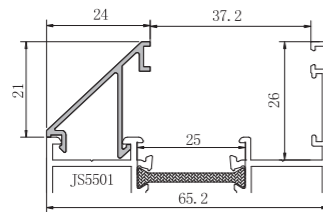

更换24隔热条为60系列

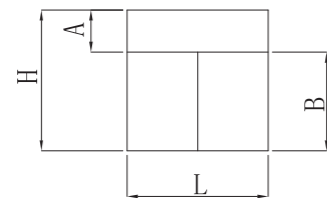

H=1500mm
L=1500mm
A=500mm
B=1000mm

用料清单 (仅供参考)

名称	型号	公式	长度 (mm)	每米重量	数量	重量(kg)
横边框	HL60B01-24	L	1500	1.224	2	3.672
竖边框	HL60B01-24	H	1500	1.224	2	3.672
横中梃	HL60B03-24	L-46	1454	1.397	1	2.031
竖中梃	HL60B03-24	B-32	968	1.397	1	1.352
上固窗横压线	HL65A48	L-56	1444	0.243	2	0.702
上固窗竖压线	HL65A48	A86	414	0.243	2	0.201
侧固窗横压线	HL65A48	L/2-42	708	0.243	2	0.344
侧固窗竖压线	HL65A48	B-86	914	0.243	2	0.444
窗扇横料	HL60B02-24	L/2-30	720	1.444	2	2.079
窗扇竖料	HL60B02-24	B-30	970	1.444	2	2.801
窗扇横压线	HL65A48	L/2-120	630.0	0.243	2	0.306
窗扇竖压线	HL65A48	B-164	836.0	0.243	2	0.406
框角码 (内)	TJM171	18.2	18.2	3.416	4	0.249
框角码 (外)	TJM171	10.2	10.2	3.416	4	0.139
扇角码 (内)	TJM171	27	27.0	3.416	4	0.369
扇角码 (外)	GR5630	4.9	4.9	2.717	4	0.053
中梃连接件 (内)	HL65A20	14	14	1.374	4	0.0769
中梃连接件 (外)	HL60B21	14	14	0.787	4	0.0441
合计 (kg)						18.943
铝窗面积	宽1.5米		高1.5米			2.25m ²
单位重量						18.943/2.25≈8.419kg/m ²

更换30隔热条为66系列

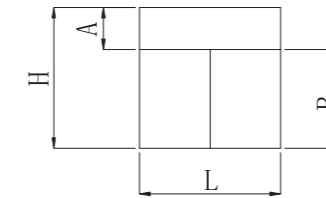

H=1500mm
L=1500mm
A=500mm
B=1000mm

用料清单 (仅供参考)

名称	型号	公式	长度 (mm)	每米重量	数量	重量(kg)
横边框	HL6066B01-30	L	1500	1.257	2	3.771
竖边框	HL6066B01-30	H	1500	1.257	2	3.771
横中梃	HL6066B03-30	L-46	1454	1.430	1	2.079
竖中梃	HL6066B03-30	B-32	968	1.430	1	1.384
上固窗横压线	HL65A45	L-56	1444	0.252	2	0.728
上固窗竖压线	HL65A45	A86	414	0.252	2	0.209
侧固窗横压线	HL65A45	L/2-42	708	0.252	2	0.357
侧固窗竖压线	HL65A45	B86	914	0.252	2	0.461
窗扇横料	HL6066B02-30	L/2-30	720	1.485	2	2.138
窗扇竖料	HL6066B02-30	B-30	970	1.485	2	2.881
窗扇横压线	HL65A45	L/2-120	630.0	0.252	2	0.318
窗扇竖压线	HL65A45	B-164	836.0	0.252	2	0.421
框角码 (内)	TJM171	18.2	18.2	3.416	4	0.249
框角码 (外)	TJM171	10.2	10.2	3.416	4	0.139
扇角码 (内)	TJM171	27	27.0	3.416	4	0.369
扇角码 (外)	GR5630	4.9	4.9	2.717	4	0.053
中梃连接件 (内)	HL65A20	14	14	1.374	4	0.0769
中梃连接件 (外)	HL60B21	14	14	0.787	4	0.0441
合计 (kg)						19.449
铝窗面积	宽1.5米		高1.5米			2.25m ²
单位重量						19.449/2.25≈8.644kg/m ²

更换34隔热条为70系列

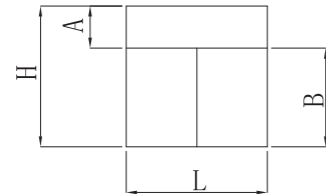

H=1500mm
L=1500mm
A=500mm
B=1000mm

用料清单 (仅供参考)

名称	型号	公式	长度 (mm)	每米重量	数量	重量(kg)
横边框	HL70B01-C34	L	1500	1.309	2	3.927
竖边框	HL70B01-C34	H	1500	1.309	2	3.927
横中框	HL70B03-C34	L-46	1454	1.482	1	2.155
竖中框	HL70B03-C34	B-32	968	1.482	1	1.435
上固窗横压线	HL65A45	L-56	1444	0.252	2	0.728
上固窗竖压线	HL65A45	A86	414	0.252	2	0.209
侧固窗横压线	HL65A45	L/2-42	708	0.252	2	0.357
侧固窗竖压线	HL65A45	B-86	914	0.252	2	0.461
窗扇横料	HL70B02-C34	L/2-30	720	1.520	2	2.189
窗扇竖料	HL70B02-C34	B-30	970	1.520	2	2.949
窗扇横压线	HL65A45	L/2-120	630.0	0.252	2	0.318
窗扇竖压线	HL65A45	B-164	836.0	0.252	2	0.421
框角码 (内)	TJM171	18.2	18.2	3.416	4	0.249
框角码 (外)	TJM171	10.2	10.2	3.416	4	0.139
扇角码 (内)	TJM171	27	27.0	3.416	4	0.369
扇角码 (外)	GR5630	4.9	4.9	2.717	4	0.053
中框连接件 (内)	HL65A20	14	14	1.374	4	0.0769
中框连接件 (外)	HL60B21	14	14	0.787	4	0.0441
合计 (kg)						20.005
铝窗面积	宽1.5米		高1.5米			2.25m ²
单位重量						20.005/2.25≈8.891kg/m ²

隔热平开窗系列

型号 Dwg NO.	HL60B01-24	HL60B03-24	HL60B02-24	HL60B63-24	HL60B06-24	HL60B15-24	HL60B16-24	HL60BPG-24	HL60B22-24	HL60B30ZH-24
名称 Profile	边框	中框	内开扇	外开扇	假中框	转换料	假中框	拼管	加强中框	拼管
壁厚(mm) Thickness	重量(kg/m) Weight	重量(kg/m) Weight	重量(kg/m) Weight	重量(kg/m) Weight	重量(kg/m) Weight	重量(kg/m) Weight	重量(kg/m) Weight	重量(kg/m) Weight	重量(kg/m) Weight	重量(kg/m) Weight
	1.8	1.397	1.8	1.667	1.8	1.082	1.8	1.545	1.8	1.07

型号 Dwg NO.	HL60B21
名称 Profile	中框插件
壁厚(mm) Thickness	重量(kg/m) Weight
2.5	0.787

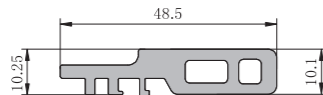

型号 Dwg NO.	HL65A20
名称 Profile	连接件
壁厚(mm) Thickness	重量(kg/m) Weight
3.0	1.374

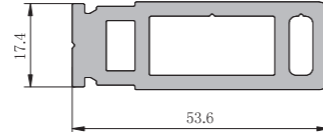

型号 Dwg NO.	FKXT
名称 Profile	附框线条
壁厚(mm) Thickness	重量(kg/m) Weight
1.0	0.183

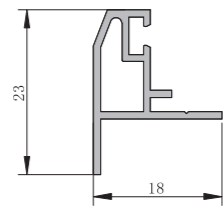

型号 Dwg NO.	HL60B28-24
名称 Profile	90° 转角
壁厚(mm) Thickness	重量(kg/m) Weight
1.8	1.884

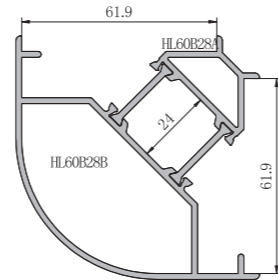

型号 Dwg NO.	TJM160
名称 Profile	角码
壁厚(mm) Thickness	重量(kg/m) Weight
4.5	5.809

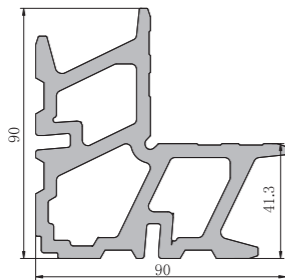

型号 Dwg NO.	TJM171
名称 Profile	角码
壁厚(mm) Thickness	重量(kg/m) Weight
8.6	3.416

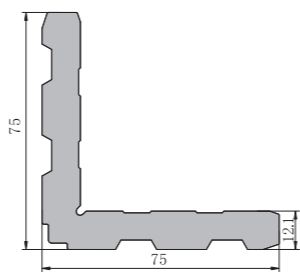

型号 Dwg NO.	TJM170
名称 Profile	角码
壁厚(mm) Thickness	重量(kg/m) Weight
4.0	4.811

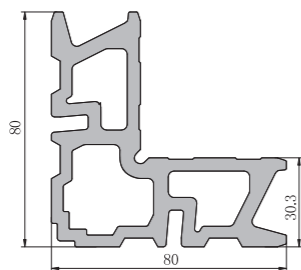

型号 Dwg NO.	TJM172
名称 Profile	角码
壁厚(mm) Thickness	重量(kg/m) Weight
4.0	4.522

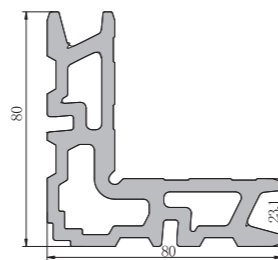

型号 Dwg NO.	GR5630
名称 Profile	角码
壁厚(mm) Thickness	重量(kg/m) Weight
	2.717

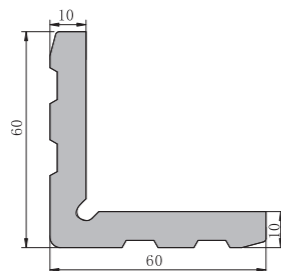

型号 Dwg NO.	HL65A45
名称 Profile	框压线
壁厚(mm) Thickness	重量(kg/m) Weight
1.1	0.252

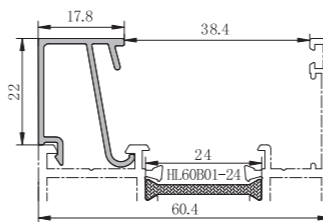

型号 Dwg NO.	HL65A51
名称 Profile	框压线
壁厚(mm) Thickness	重量(kg/m) Weight
1.1	0.318

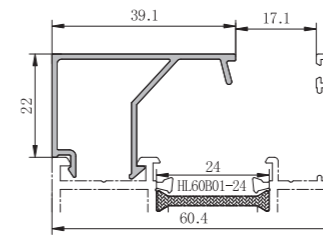

型号 Dwg NO.	HL65B45
名称 Profile	扇压线
壁厚(mm) Thickness	重量(kg/m) Weight
1.1	0.248

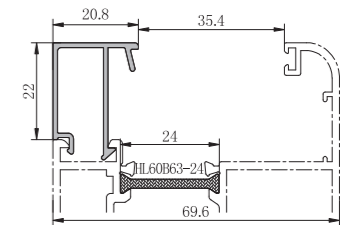

型号 Dwg NO.	HL65A48
名称 Profile	框压线
壁厚(mm) Thickness	重量(kg/m) Weight
1.1	0.243

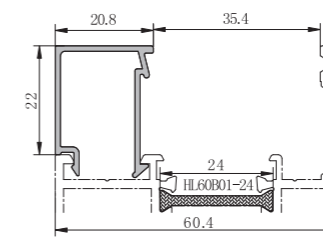

型号 Dwg NO.	HL65B45-2
名称 Profile	扇压线
壁厚(mm) Thickness	重量(kg/m) Weight
1.1	0.232

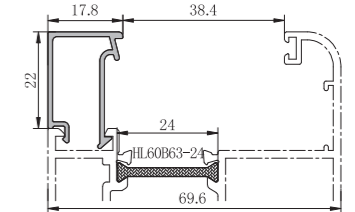

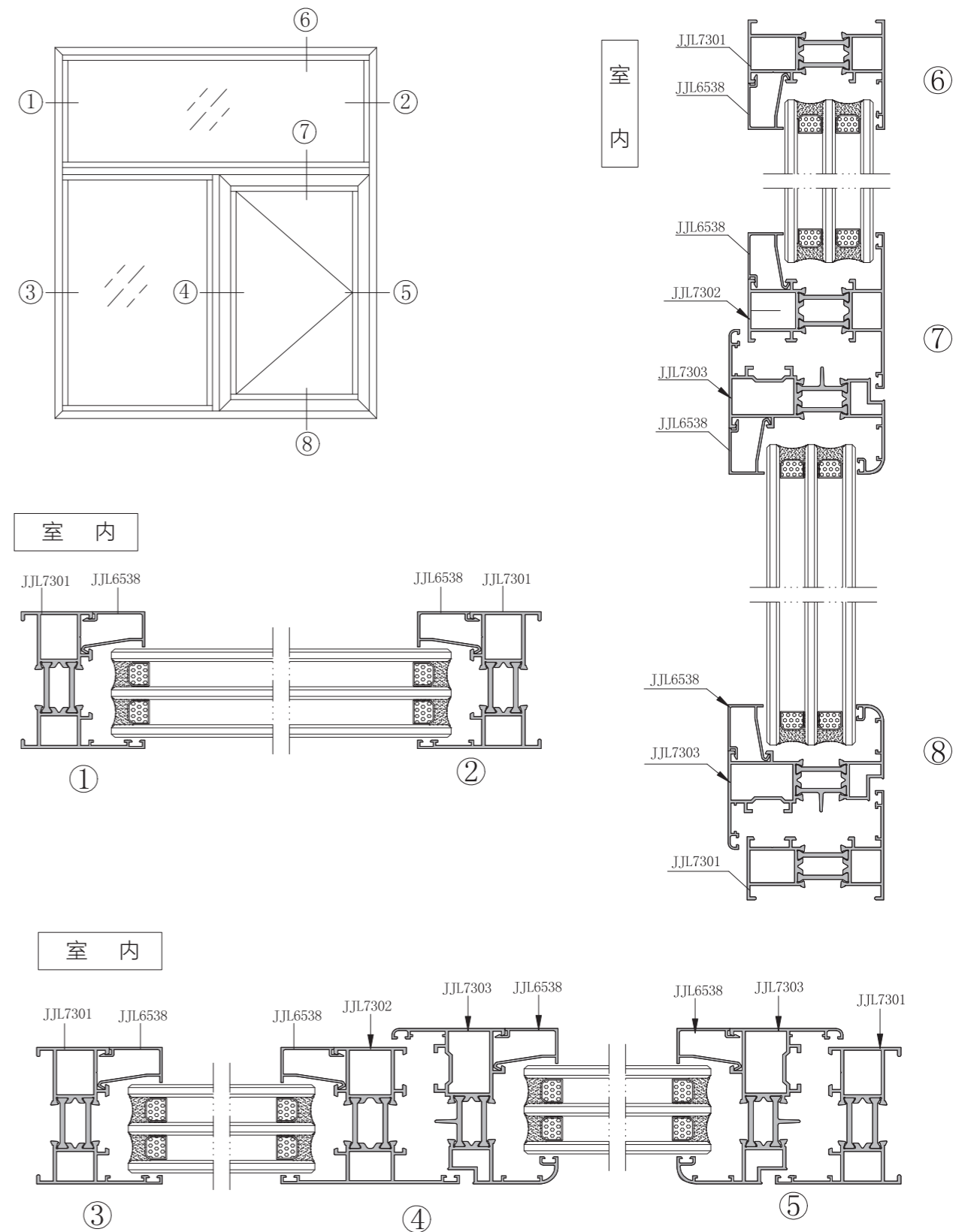
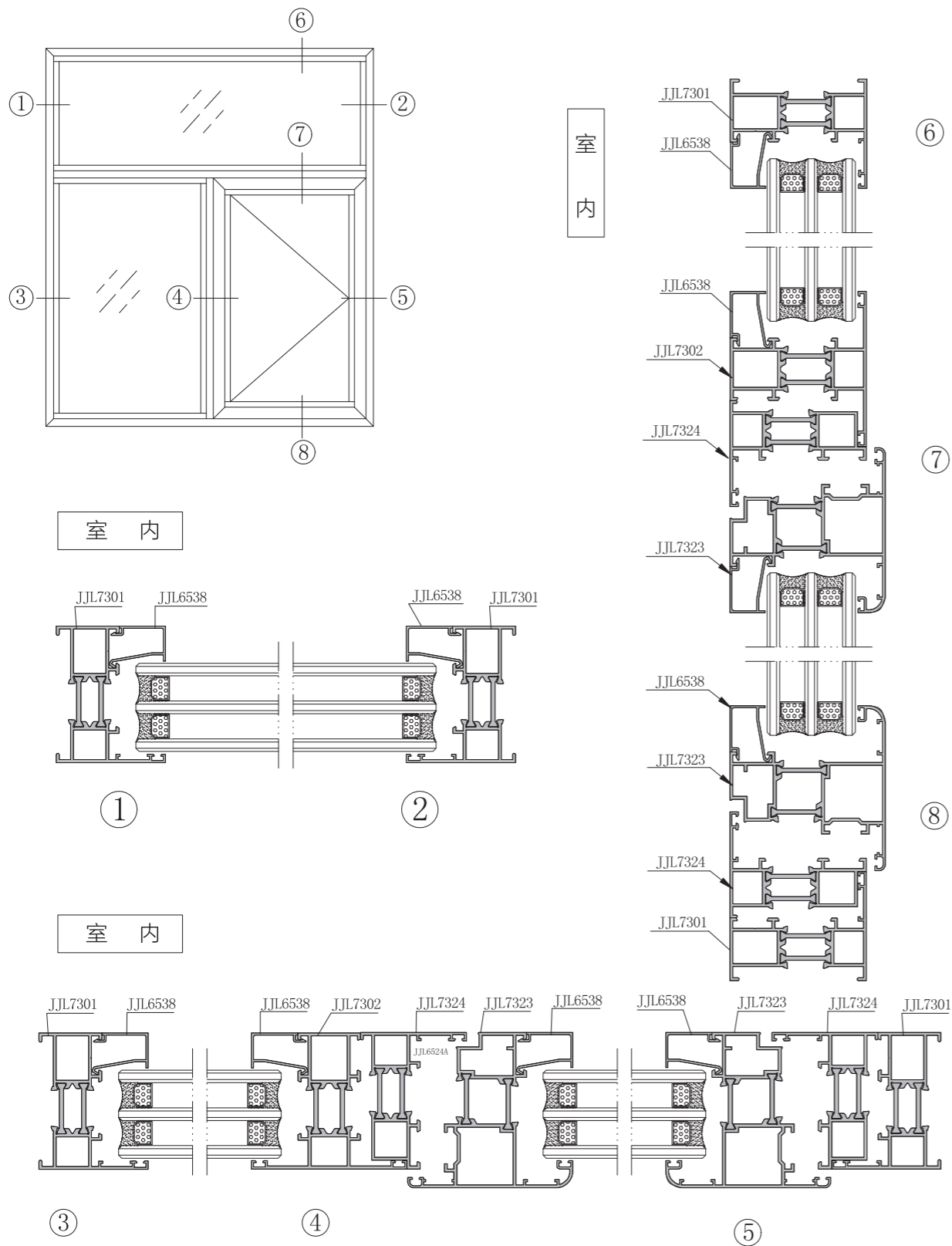

更换24隔热条为65系列

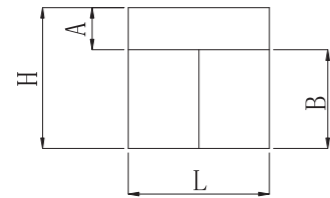

H=1500mm
L=1500mm
A=500mm
B=1000mm

用料清单 (仅供参考)

名称	型号	公式	长度 (mm)	每米重量	数量	重量(kg)
横边框	JJL7301	L	1500	1.132	2	3.396
竖边框	JJL7301	H	1500	1.132	2	3.396
横中框	JJL7302	L-50	1450	1.273	1	1.846
竖中框	JJL7302	B-35	965	1.273	1	1.228
上固窗横压线	JJL6538	L-60	1440	0.205	2	0.590
上固窗竖压线	JJL6538	A-89	411	0.205	2	0.169
侧固窗横压线	JJL6538	L/2-45	705	0.205	2	0.289
侧固窗竖压线	JJL6538	B-89	911	0.205	2	0.374
窗扇横料	JJL7303	L/2-33	717	1.348	2	1.933
窗扇竖料	JJL7303	B-33	967	1.348	2	2.607
窗扇横压线	JJL6538	L/2-126.6	623.4	0.205	2	0.256
窗扇竖压线	JJL6538	B-170.6	829	0.205	2	0.340
框角码 (内)	JJL6536	20.7	20.7	2.077	4	0.172
框角码 (外)	JJL6536	13.7	13.7	2.077	4	0.114
扇角码 (内)	JJL6536	28.9	28.9	2.077	4	0.240
扇角码 (外)	JJL6536	7.7	7.7	2.077	4	0.064
合计 (kg)						17.013
铝窗面积	宽1.5米	高1.5米				2.25m ²
单位重量						17.013/2.25≈7.561kg/m ²

更换20隔热条为60系列

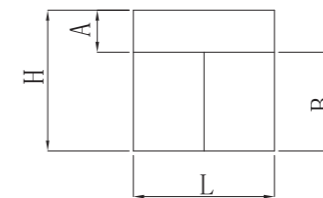

H=1500mm
L=1500mm
A=500mm
B=1000mm

用料清单 (仅供参考)

名称	型号	公式	长度 (mm)	每米重量	数量	重量(kg)
横边框	JJL6001	L	1500	1.110	2	3.330
竖边框	JJL6001	H	1500	1.110	2	3.330
横中框	JJL6002	L-50	1450	1.252	1	1.815
竖中框	JJL6002	B-35	965	1.252	1	1.208
上固窗横压线	JJL6538	L-60	1440	0.205	2	0.590
上固窗竖压线	JJL6538	A89	411	0.205	2	0.169
侧固窗横压线	JJL6538	L/2-45	705	0.205	2	0.289
侧固窗竖压线	JJL6538	B-89	911	0.205	2	0.374
窗扇横料	JJL6003	L/2-33	717	1.326	2	1.901
窗扇竖料	JJL6003	B-33	967	1.326	2	2.564
窗扇横压线	JJL6538	L/2-126.6	623.4	0.205	2	0.256
窗扇竖压线	JJL6538	B-170.6	829.4	0.205	2	0.340
框角码 (内)	JJL6536	20.7	20.7	2.077	4	0.172
框角码 (外)	JJL6536	13.7	13.7	2.077	4	0.114
扇角码 (内)	JJL6536	28.9	28.9	2.077	4	0.240
扇角码 (外)	JJL6536	7.7	7.7	2.077	4	0.064
合计 (kg)						16.757
铝窗面积	宽1.5米	高1.5米				2.25m ²
单位重量						16.757/2.25≈7.447kg/m ²

型号 Dwg NO.	JJL7301
名称 Profile	边框
壁厚(mm) Thickness	重量(kg/m) Weight
1.4	1.132

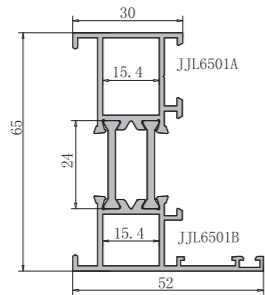

配套角码: JJL6536

型号 Dwg NO.	JJL7302
名称 Profile	中梃
壁厚(mm) Thickness	重量(kg/m) Weight
1.4	1.273

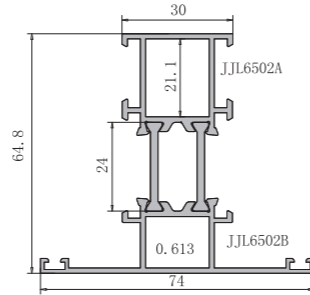

配套角码: JJL6537 JJL6539

型号 Dwg NO.	JJL7322
名称 Profile	中梃
壁厚(mm) Thickness	重量(kg/m) Weight
1.4	1.341

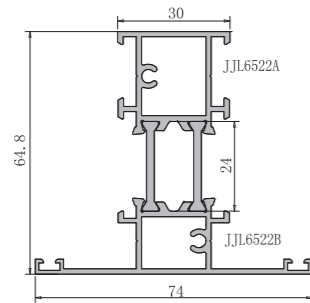

型号 Dwg NO.	JJL7303
名称 Profile	内开扇
壁厚(mm) Thickness	重量(kg/m) Weight
1.4	1.348

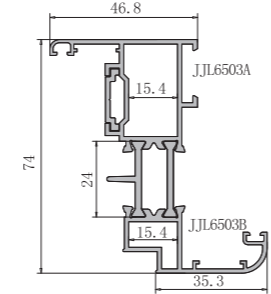

配套角码: JJL6536

型号 Dwg NO.	JJL7323
名称 Profile	外开扇
壁厚(mm) Thickness	重量(kg/m) Weight
1.4	1.488

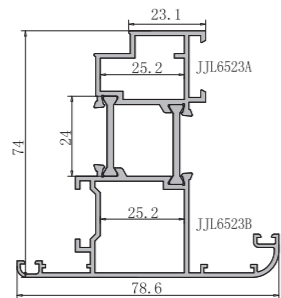

配套角码: JJL65M06

型号 Dwg NO.	JJL7334
名称 Profile	转换料
壁厚(mm) Thickness	重量(kg/m) Weight
1.4	0.887

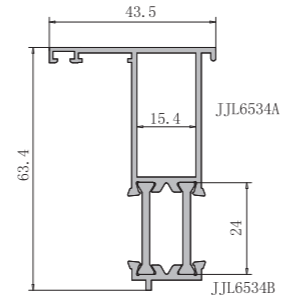

配套角码: JJL6536

型号 Dwg NO.	JJL7333
名称 Profile	外开扇
壁厚(mm) Thickness	重量(kg/m) Weight
1.4	1.416

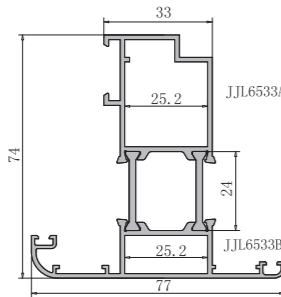

配套角码: JJL65M06

型号 Dwg NO.	JJL7324
名称 Profile	转换料
壁厚(mm) Thickness	重量(kg/m) Weight
1.4	1.07

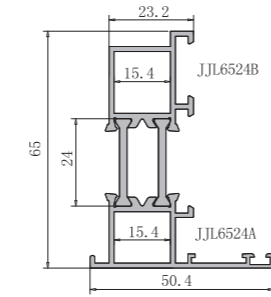

配套角码: JJL6536

型号 Dwg NO.	JJL7312
名称 Profile	加强中梃
壁厚(mm) Thickness	重量(kg/m) Weight
1.4	1.606

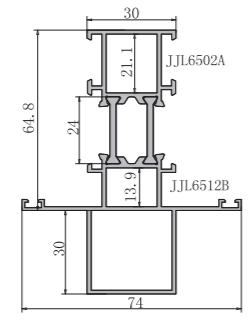

配套角码: JJL6537 JJL6539

型号 Dwg NO.	JJL7352
名称 Profile	加强螺栓中梃
壁厚(mm) Thickness	重量(kg/m) Weight
1.4	1.753

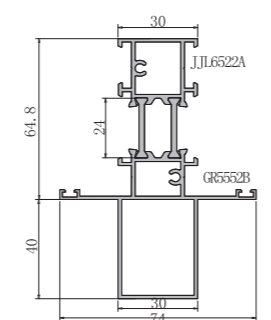

型号 Dwg NO.	JJL6537
名称 Profile	中梃连接件
壁厚(mm) Thickness	重量(kg/m) Weight
	1.171

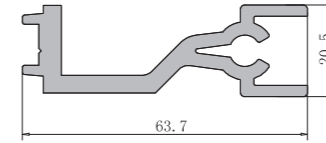

系统代号: JJL7337

型号 Dwg NO.	JJL6539
名称 Profile	中梃连接件
壁厚(mm) Thickness	重量(kg/m) Weight
	1.113

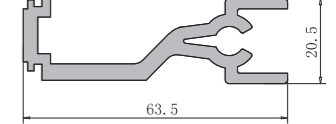

系统代号: JJL7339

型号 Dwg NO.	JJL6536
名称 Profile	角码
壁厚(mm) Thickness	重量(kg/m) Weight
3.0	2.077

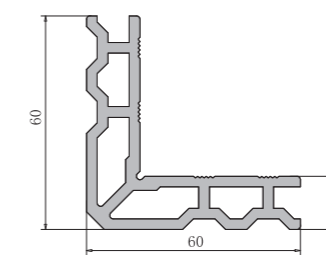

系统代号: JJL7336

型号 Dwg NO.	JJL6538
名称 Profile	压线
壁厚(mm) Thickness	重量(kg/m) Weight
1.0	0.205

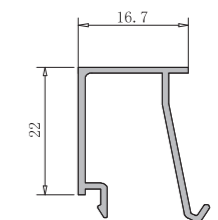

系统代号: JJL7338

型号 Dwg NO.	JJL6540
名称 Profile	拼条
壁厚(mm) Thickness	重量(kg/m) Weight
1.4	0.103

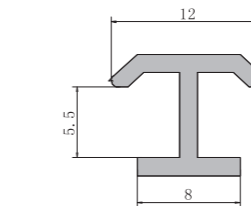

型号 Dwg NO.	6810H-20
名称 Profile	拼管
壁厚(mm) Thickness	重量(kg/m) Weight
1.4	0.972

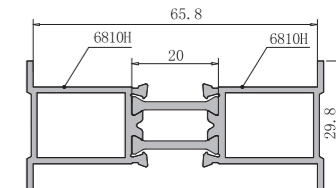

型号 Dwg NO.	GR8065
名称 Profile	隔热方管
壁厚(mm) Thickness	重量(kg/m) Weight
1.2	1.695

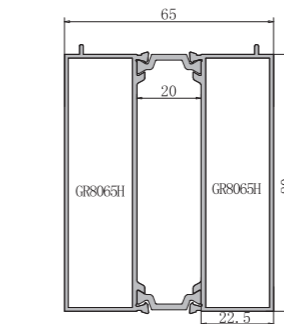

型号 Dwg NO.	ZL6505
名称 Profile	90° 转角
壁厚(mm) Thickness	重量(kg/m) Weight
1.4	1.488

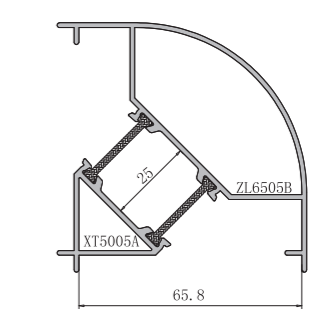

型号 Dwg NO.	LH65135B-ZH
名称 Profile	135° 转角
壁厚(mm) Thickness	重量(kg/m) Weight
1.75	1.423

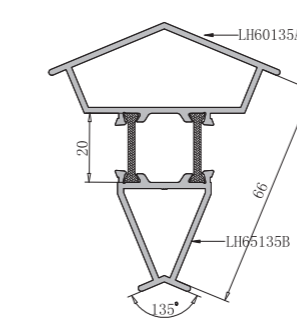

型号 Dwg NO.	JJL7335
名称 Profile	转角边框
壁厚(mm) Thickness	重量(kg/m) Weight
1.4	1.876

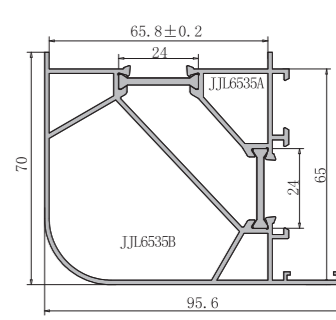

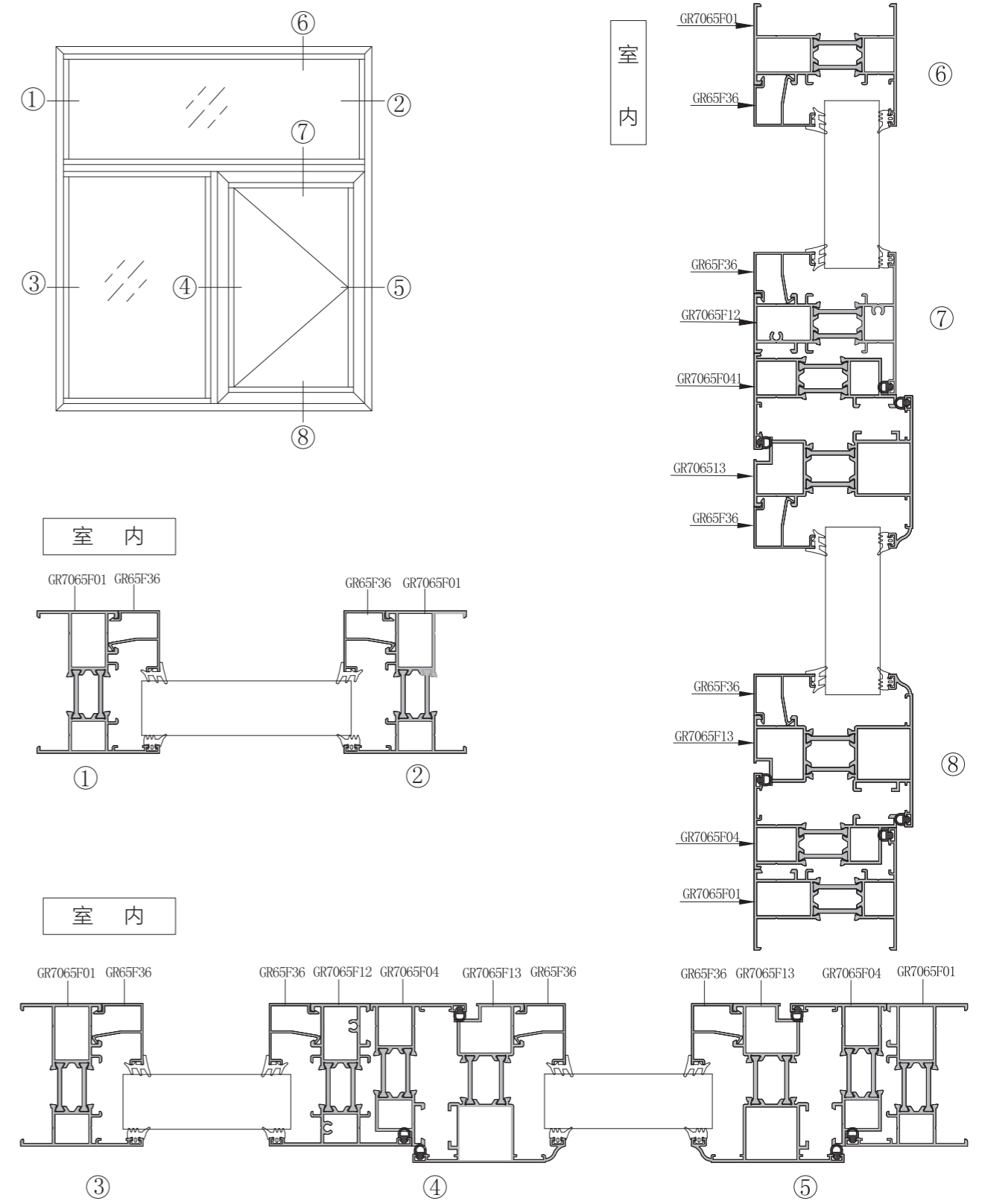
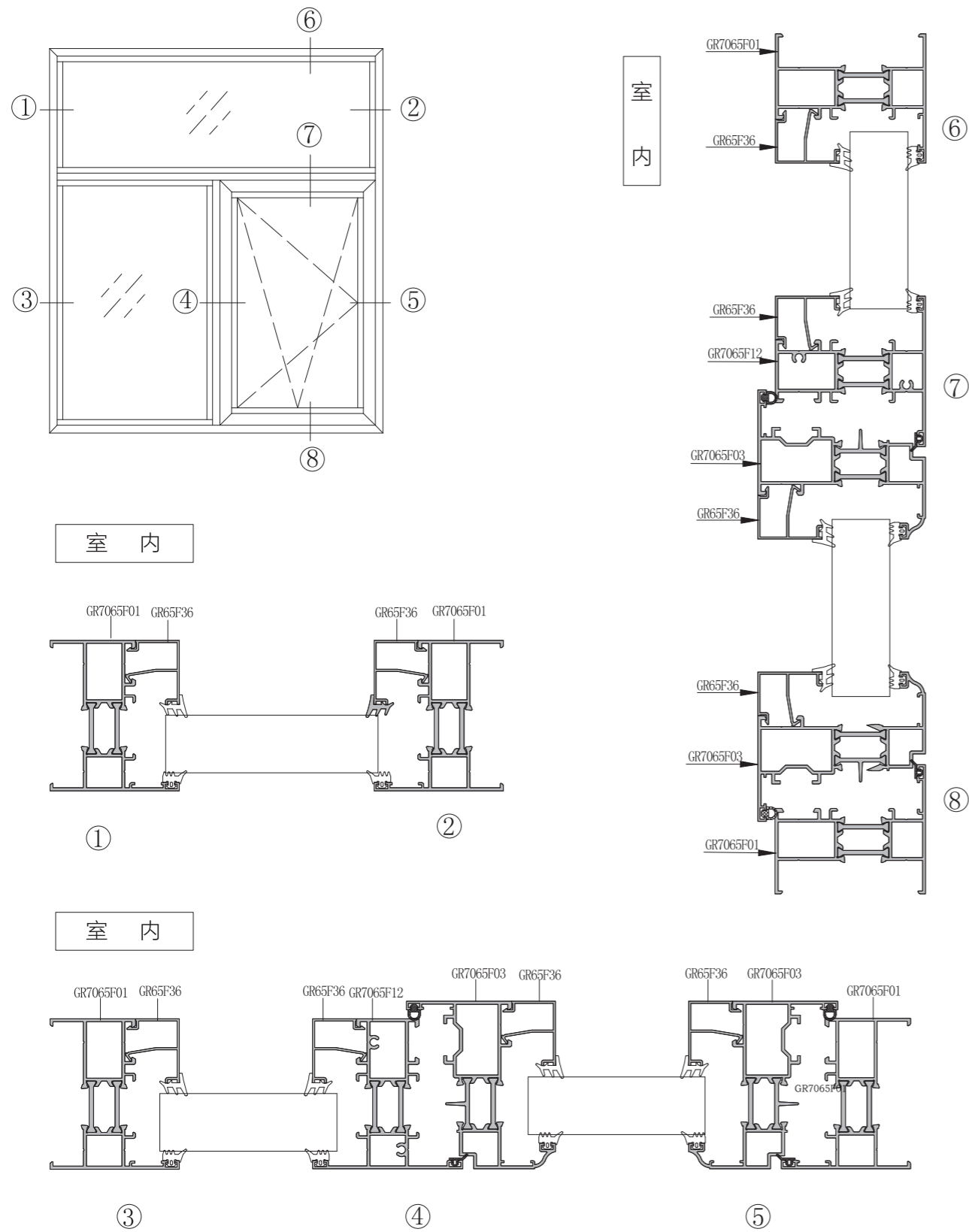

更换18.6隔热条为65系列

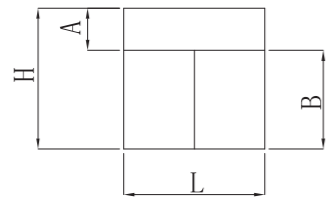

H=1500mm
L=1500mm
A=500mm
B=1000mm

用料清单 (仅供参考)

名称	型号	公式	长度 (mm)	每米重量	数量	重量(kg)
横边框	GR65F01	L	1500	1.209	2	3.627
竖边框	GR65F01	H	1500	1.209	2	3.627
横中框	GR65F12	L-70	1430	1.395	1	1.995
竖中框	GR65F12	B-44.7	955.3	1.395	1	1.333
上固窗横压线	GR65F36	L-80	1420	0.252	2	0.716
上固窗竖压线	GR65F36	A-95.7	404.3	0.252	2	0.204
侧固窗横压线	GR65F36	L/2-54.7	695.3	0.252	2	0.350
侧固窗竖压线	GR65F36	B-95.7	904.3	0.252	2	0.456
窗扇横料	GR65F03	L/2-42.7	707.3	1.333	2	1886
窗扇竖料	GR65F03	B-42.7	957.3	1.333	2	2.552
窗扇横压线	GR65F36	L/2-141.3	608.7	0.252	2	0.307
窗扇竖压线	GR65F36	B-182.3	817.7	0.252	2	0.412
框角码 (内)	GR60F07	26	26.0	2.820	4	0.293
框角码 (外)	GR60F07	14	14.0	2.820	4	0.158
扇角码 (内)	GR60F07	32.7	32.7	2.820	4	0.369
扇角码 (外)	GR60F07	9.3	9.3	2.820	4	0.105
合计 (kg)						18.389
铝窗面积	宽1.5米	高1.5米				2.25m ²
单位重量	18.389/2.25≈8.173kg/m ²					

更换24隔热条为70系列

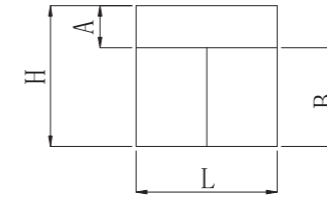

H=1500mm
L=1500mm
A=500mm
B=1000mm

用料清单 (仅供参考)

名称	型号	公式	长度 (mm)	每米重量	数量	重量(kg)
横边框	GR7065F01	L	1500	1.238	2	3.714
竖边框	GR7065F01	H	1500	1.238	2	3.714
横中框	GR7065F12	L-70	1430	1.368	1	1.956
竖中框	GR7065F12	B-44.7	955.3	1.368	1	1.307
上固窗横压线	GR65F36	L-80	1420	0.252	2	0.716
上固窗竖压线	GR65F36	A-95.7	404.3	0.252	2	0.204
侧固窗横压线	GR65F36	L/2-54.7	695.3	0.252	2	0.350
侧固窗竖压线	GR65F36	B-95.7	904.3	0.252	2	0.456
窗扇横料	GR7065F03	L/2-42.7	707.3	1.369	2	1.937
窗扇竖料	GR7065F03	B-42.7	957.3	1.369	2	2.621
窗扇横压线	GR65F36	L/2-141.3	608.7	0.252	2	0.307
窗扇竖压线	GR65F36	B-182.3	817.7	0.252	2	0.412
框角码 (内)	GR60F07	26	26.0	2.820	4	0.293
框角码 (外)	GR60F07	14	14.0	2.820	4	0.158
扇角码 (内)	GR60F07	32.7	32.7	2.820	4	0.369
扇角码 (外)	GR60F07	9.3	9.3	2.820	4	0.105
合计 (kg)						18.618
铝窗面积	宽1.5米	高1.5米				2.25m ²
单位重量	18.618/2.25≈8.275kg/m ²					

更换30隔热条为76系列

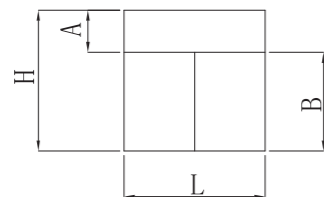

H=1500mm
L=1500mm
A=500mm
B=1000mm

用料清单 (仅供参考)

名称	型号	公式	长度 (mm)	每米重量	数量	重量(kg)
横边框	GR7665F01C	L	1500	1.302	2	3.906
竖边框	GR7665F01C	H	1500	1.302	2	3.906
横中框	GR7665F12C	L-70	1430	1.436	1	2.053
竖中框	GR7665F12C	B-44.7	955.3	1.436	1	1.372
上固窗横压线	GR65F36	L-80	1420	0.252	2	0.716
上固窗竖压线	GR65F36	A-95.7	404.3	0.252	2	0.204
侧固窗横压线	GR65F36	L/2-54.7	695.3	0.252	2	0.350
侧固窗竖压线	GR65F36	B-95.7	904.3	0.252	2	0.456
窗扇横料	GR7665F03C	L/2-42.7	707.3	1.420	2	2.009
窗扇竖料	GR7665F03C	B-42.7	957.3	1.420	2	2.719
窗扇横压线	GR65F36	L/2-141.3	608.7	0.252	2	0.307
窗扇竖压线	GR65F36	B-182.3	817.7	0.252	2	0.412
框角码 (内)	GR60F07	26	26.0	2.820	4	0.293
框角码 (外)	GR60F07	14	14.0	2.820	4	0.158
扇角码 (内)	GR60F07	32.7	32.7	2.820	4	0.369
扇角码 (外)	GR60F07	9.3	9.3	2.820	4	0.105
合计 (kg)						19.334
铝窗面积	宽1.5米		高1.5米			2.25m ²
单位重量						19.334/2.25≈8.593kg/m ²

型号 Dwg NO.	名称 Profile	壁厚(mm) Thickness	重量(kg/m) Weight	断面简图	配套角码
GR7065F01	边框	1.4	1.238		GR60F07
GR7065F31	边框	1.4	1.229		GR60F07
GR7065F11	边框	1.4	1.201		GR60F07
GR7065F12	螺接中框	1.4	1.368		
GR7065F02	中框	1.4	1.372		
GR7065F33	内开扇	1.4	1.36		GR60F07
GR7065F03	内开扇	1.4	1.369		GR60F07
GR7065F32	挂纱内开扇	1.4	1.317		GR60F07
GR7065F43	内开扇	1.4	1.409		
GR7065F13	外开扇	1.4	1.498		GR5517

型号 Dwg NO.	GR7065F63
名称 Profile	内开扇
壁厚(mm) Thickness	重量(kg/m) Weight
1.4	1.361

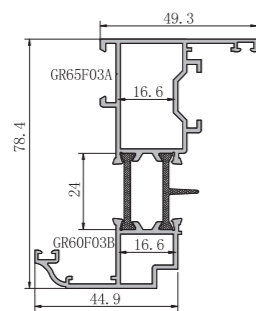

型号 Dwg NO.	GR7065F04
名称 Profile	转换料
壁厚(mm) Thickness	重量(kg/m) Weight
1.4	1.055

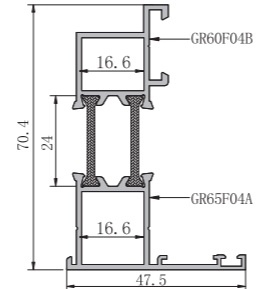

配套角码: GR60F07

型号 Dwg NO.	GR7065F32
名称 Profile	加强螺栓中框
壁厚(mm) Thickness	重量(kg/m) Weight
1.4	1.727

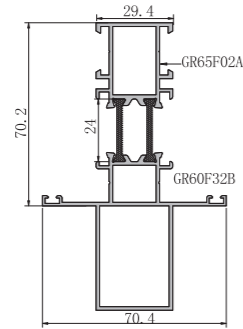

型号 Dwg NO.	GR70E135A-ZH
名称 Profile	135° 转角
壁厚(mm) Thickness	重量(kg/m) Weight
1.4	1.344

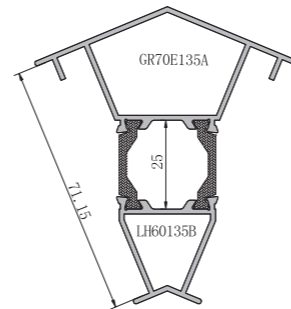

型号 Dwg NO.	GR70E28
名称 Profile	90° 转角
壁厚(mm) Thickness	重量(kg/m) Weight
1.4	1.558

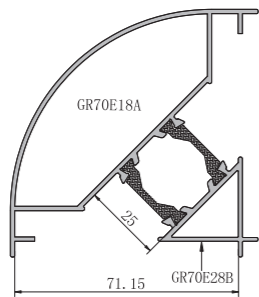

型号 Dwg NO.	GR5529
名称 Profile	拼条
壁厚(mm) Thickness	重量(kg/m) Weight
	0.097

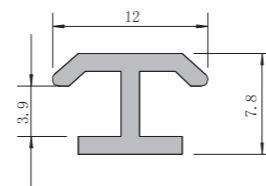

型号 Dwg NO.	GR5517
名称 Profile	角码
壁厚(mm) Thickness	重量(kg/m) Weight
3.0	2.328

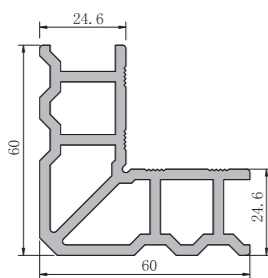

型号 Dwg NO.	GR60F07
名称 Profile	角码
壁厚(mm) Thickness	重量(kg/m) Weight
	2.820

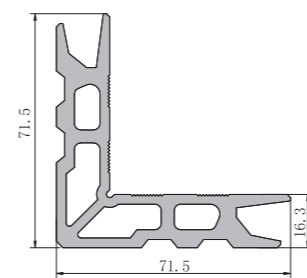

型号 Dwg NO.	GR60F18
名称 Profile	中框插件
壁厚(mm) Thickness	重量(kg/m) Weight
	0.711

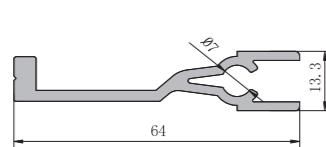

型号 Dwg NO.	GR65F08
名称 Profile	中框插件
壁厚(mm) Thickness	重量(kg/m) Weight
	1.193

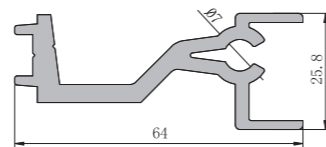

型号 Dwg NO.	GR65F06
名称 Profile	压线
壁厚(mm) Thickness	重量(kg/m) Weight
1.0	0.198

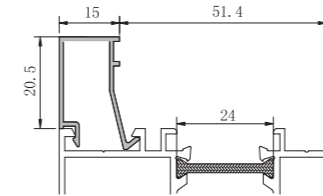

型号 Dwg NO.	WL75007
名称 Profile	压线
壁厚(mm) Thickness	重量(kg/m) Weight
1.4	0.328

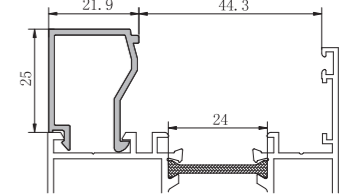

型号 Dwg NO.	XT52M06
名称 Profile	压线
壁厚(mm) Thickness	重量(kg/m) Weight
1.0	0.238

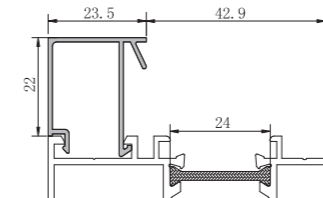

型号 Dwg NO.	GR65F36
名称 Profile	压线
壁厚(mm) Thickness	重量(kg/m) Weight
1.0	0.252

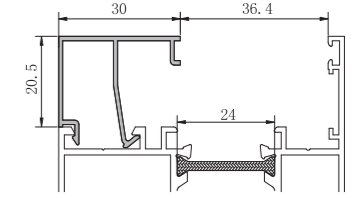

型号 Dwg NO.	GR65F16
名称 Profile	压线
壁厚(mm) Thickness	重量(kg/m) Weight
1.0	0.258

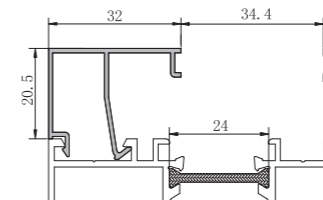

型号 Dwg NO.	WL75006
名称 Profile	压线
壁厚(mm) Thickness	重量(kg/m) Weight
1.4	0.406

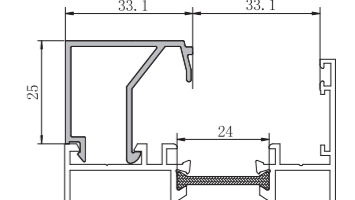

型号 Dwg NO.	XD-50D16
名称 Profile	压线
壁厚(mm) Thickness	重量(kg/m) Weight
0.9	0.245

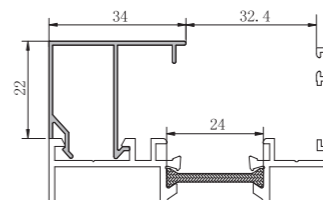

型号 Dwg NO.	ZL10026
名称 Profile	压线
壁厚(mm) Thickness	重量(kg/m) Weight
0.8	0.243

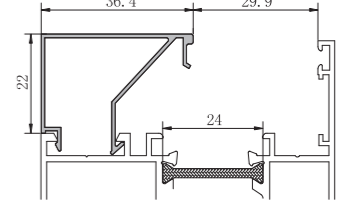

型号 Dwg NO.	SDL2277
名称 Profile	压线
壁厚(mm) Thickness	重量(kg/m) Weight
1.2	0.329

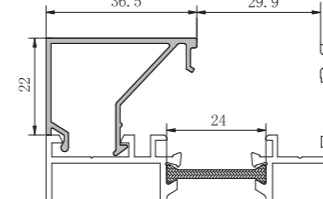

型号 Dwg NO.	ZL11026
名称 Profile	压线
壁厚(mm) Thickness	重量(kg/m) Weight
1.0	0.323

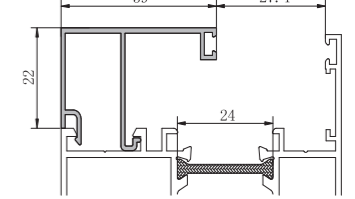

型号 Dwg NO.	SBR7205B
名称 Profile	压线
壁厚(mm) Thickness	重量(kg/m) Weight
1.0	0.255

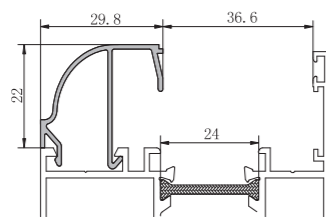

型号 Dwg NO.	GR65FM06
名称 Profile	压线
壁厚(mm) Thickness	重量(kg/m) Weight
1.0	0.258

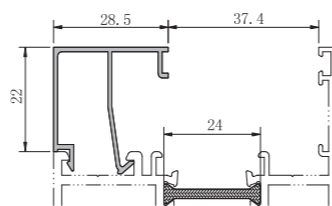

型号 Dwg NO.	PC8007
名称 Profile	压线
壁厚(mm) Thickness	重量(kg/m) Weight
1.0	0.229

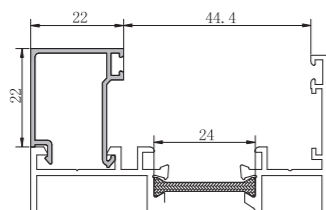

型号 Dwg NO.	ZL10046
名称 Profile	压线
壁厚(mm) Thickness	重量(kg/m) Weight
1.0	0.274

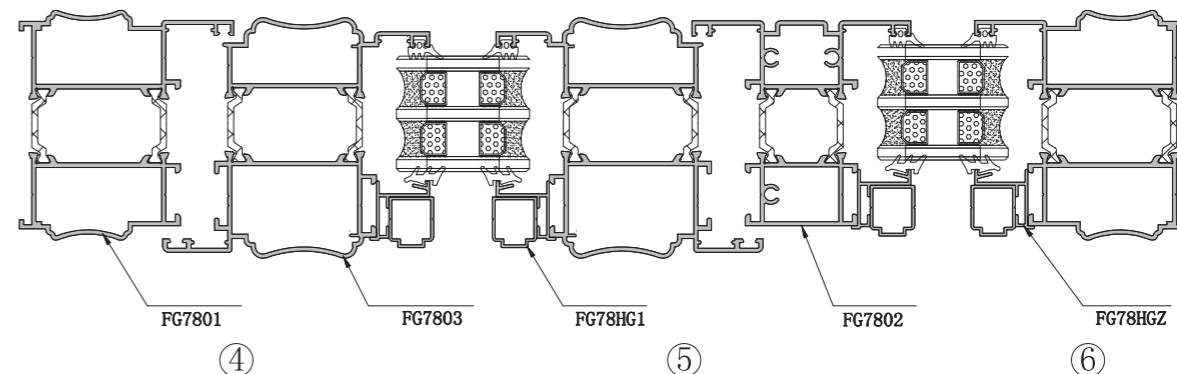
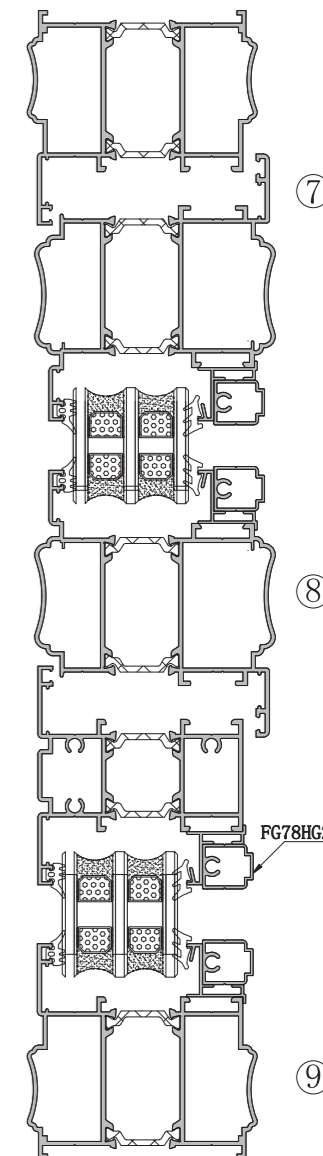
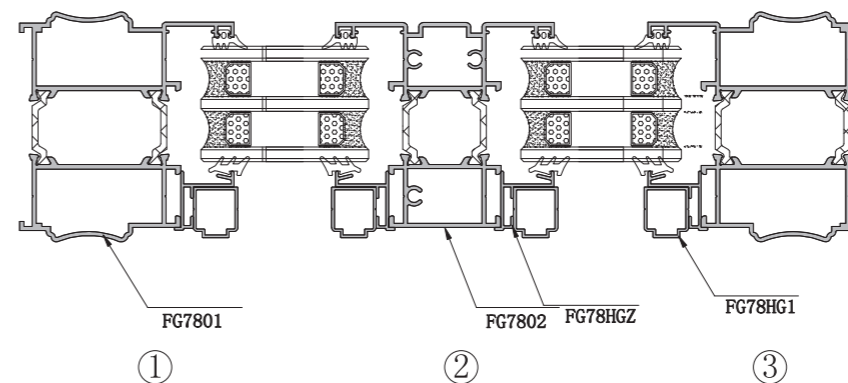
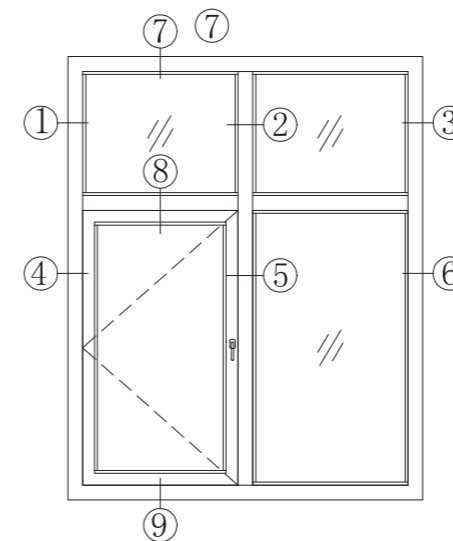
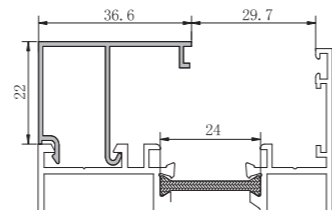

型号 Dwg NO.	FG7801
名称 Profile	边框
壁厚(mm) Thickness	重量(kg/m) Weight
1.4	1.652

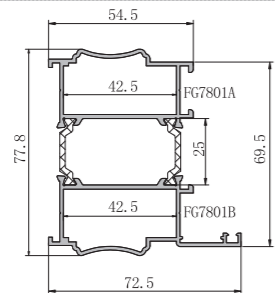

配套角码: JYL65M07

型号 Dwg NO.	FG7802
名称 Profile	螺接中梃
壁厚(mm) Thickness	重量(kg/m) Weight
1.4	1.548

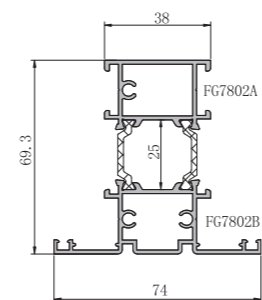

型号 Dwg NO.	FG7803
名称 Profile	扇料
壁厚(mm) Thickness	重量(kg/m) Weight
1.4	1.755

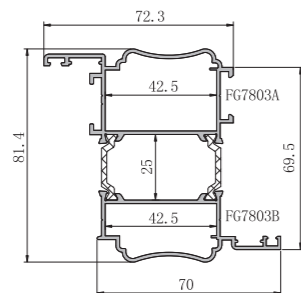

配套角码: JYL65M07

型号 Dwg NO.	FG7814
名称 Profile	转换料
壁厚(mm) Thickness	重量(kg/m) Weight
1.4	1.17

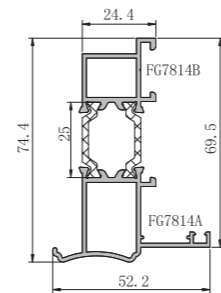

配套角码: GR60F07

型号 Dwg NO.	FG7811
名称 Profile	边框
壁厚(mm) Thickness	重量(kg/m) Weight
1.4	1.663

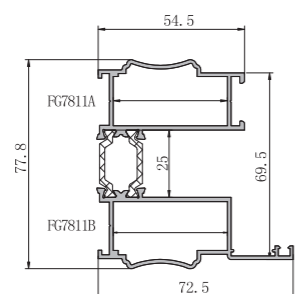

配套角码: JYL65M07

型号 Dwg NO.	FG7816
名称 Profile	螺接中梃
壁厚(mm) Thickness	重量(kg/m) Weight
1.4	1.759

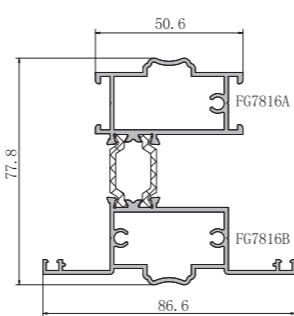

型号 Dwg NO.	FG7812-1.4
名称 Profile	中梃
壁厚(mm) Thickness	重量(kg/m) Weight
1.4	1.703

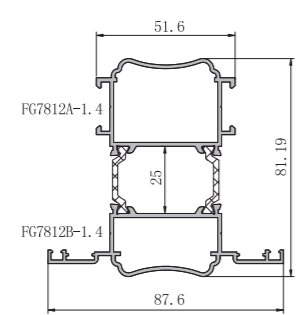

型号 Dwg NO.	FG7805
名称 Profile	假中梃
壁厚(mm) Thickness	重量(kg/m) Weight
1.4	1.247

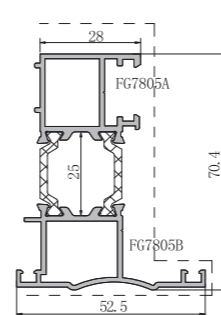

型号 Dwg NO.	FG7801-2.0
名称 Profile	边框
壁厚(mm) Thickness	重量(kg/m) Weight
2.0	2.067

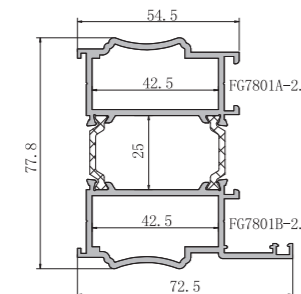

配套角码: JYL65M07

型号 Dwg NO.	FG7803-2.0
名称 Profile	扇料
壁厚(mm) Thickness	重量(kg/m) Weight
2.0	2.26

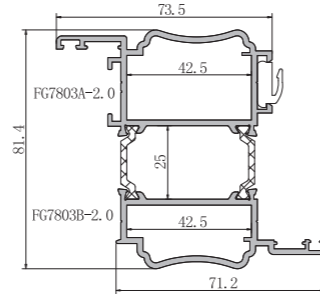

配套角码: JYL65M07

型号 Dwg NO.	FG7818
名称 Profile	压线
壁厚(mm) Thickness	重量(kg/m) Weight
1.1	0.23

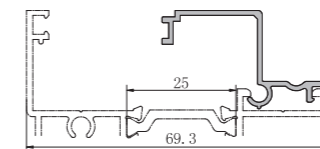

型号 Dwg NO.	FG78HG1
名称 Profile	方格
壁厚(mm) Thickness	重量(kg/m) Weight
1.0	0.16

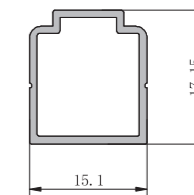

型号 Dwg NO.	FG78HGZ
名称 Profile	压座
壁厚(mm) Thickness	重量(kg/m) Weight
0.9	0.15

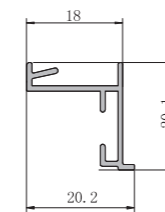

型号 Dwg NO.	FG78HG2
名称 Profile	方格
壁厚(mm) Thickness	重量(kg/m) Weight
1.0	0.19

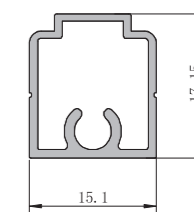

型号 Dwg NO.	FG78YX
名称 Profile	压线
壁厚(mm) Thickness	重量(kg/m) Weight
1.1	0.34

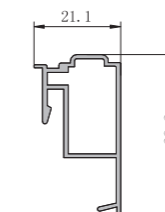

型号 Dwg NO.	
名称 Profile	
壁厚(mm) Thickness	重量(kg/m) Weight

型号 Dwg NO.	
名称 Profile	
壁厚(mm) Thickness	重量(kg/m) Weight

型号 Dwg NO.	
名称 Profile	
壁厚(mm) Thickness	重量(kg/m) Weight

型号 Dwg NO.	
名称 Profile	
壁厚(mm) Thickness	重量(kg/m) Weight

型号 Dwg NO.	
名称 Profile	
壁厚(mm) Thickness	重量(kg/m) Weight